

# Design and Fabrication of Tig Welding Machine

Mr. T. Sathish<sup>a</sup>

<sup>a</sup>, Assistant Professor,  
Department of Mechanical Engineering,  
Gnanamani College of Technology, namakkal Tamilnadu,  
India

S. Seenu<sup>b</sup>, S. Shankarsiva<sup>c</sup>,

I. Surya Abinash<sup>d</sup>, M. Tamilarasan<sup>e</sup>

<sup>b,c,d,e</sup> UG Scholar,  
Department of Mechanical Engineering,  
Gnanamani College of Technology, namakkal Tamilnadu,  
India

**Abstract:-** There are number of welding methods available for welding materials such as shielded metal arc welding, Gas metal arc welding, Flux cored arc welding, submerged arc welding, electro slag welding, electron beam welding, and Gas Tungsten arc welding methods. The choice of the welding depends on several factors; primarily among them are the compositional range of the material to be welded, the thickness of the base materials and type of current. Tungsten inert gas (TIG) welding is the most popular gas shielding arc welding process used in many industrial fields. Other arc welding processes have limited quality when they are compared to TIG welding processes. However, TIG welding also needs improvements regarding spatter reduction and weld quality of the bead. Shielding gas in TIG welding is desirable for protection of atmospheric contamination. TIG welding process has the possibility of becoming a new welding process giving high quality and provides relatively pollution free.

In this case study, we discuss the influence of the power source, type of current, gas flow rate, electrodes, filler wire, TIG Machines settings, and shielding gases which are most important in determine arc stability, arc penetration and defect free welds. To do this a thorough literature survey is carried out on various aspects of the proposed topic, in various peer-reviewed journals, patents, books and other research resources. We have identified the suitable range of current, the thickness of the base metal, the diameter of electrode, the composition of electrode and filler wire, the gas flow rate required for high quality TIG welding process.

**Keywords -** TIG welding, Shielding gas, Defect, Electrode, Filler wire, Type of current

## I. INTRODUCTION

### 1.1 Background

TIG welding was, like MIG/MAG developed during 1940 at the start of the Second World War. TIG's development came about to help in the welding of difficult types of material, example aluminum and magnesium. The use of TIG today has spread to a variety of metals like stainless mild and high tensile steels.

Arc welding is a technique to melt and join different materials that is widely used in the industry. The gas tungsten arc welding (GTAW) process is sometimes referred to as TIG, or heliarc. The term TIG is short for

tungsten inert gas welding. Under the correct welding conditions, the tungsten electrode does not melt and is considered to be non consumable. To make a weld, either the edges of the metal must melt and flow together by themselves or filler metal must be added directly into the molten pool. Filler metal is added by dipping the end of a filler rod into the leading edge of the molten weld pool. Most metals oxidize rapidly in their molten state.

To prevent oxidation from occurring, an inert gas flows out of the welding torch, surrounding the hot tungsten and molten weld metal shielding it from atmospheric oxygen. GTA welding is efficient for welding metals ranging from sheet metal up to 1/4 in. The eye-hand coordination required to make TIG welds is very similar to the coordination required for oxy- fuel gas welding.

Although most other welding processes are faster and less expensive, the clean, neat, slag-free welds GTAW produces are used because of their appearance and ease of finishing. The TIG welding process is so good that it is widely used in the high-tech industry applications such as, nuclear industry, aircraft, food industry, maintenance and repair work and some manufacturing areas [1, 2]. TIG welding is a welding process that uses a power source, a shielding gas and a TIG hand piece. An electric arc is then created between the tungsten electrode and the work piece. The tungsten and the welding zone are protected from the surrounding air by a gas shield (inert gas). The electric arc can produce temperatures of up to 19,400<sup>o</sup> C and this heat can be much focused local heat.

## I. LITERATURE REVIEW

In this chapter an overview of TIG welding process, equipments, power sources, types of electrode, shielding gases, types of current, gas flow rate will be discussed. This will give a brief overview on TIG welding parameters and techniques used for this study. TIG processes can weld practically all ferrous and nonferrous materials to themselves or to very similar alloy compositions. For welding dissimilar metals, TIG is the process of choice, permitting carbon steels to be joined to stainless or to

copper alloys. Before opting for such designs, however, consideration should be given to consequent effects, such as galvanic corrosion and differences in expansion coefficients and conductivity. Welding dissimilar metals requires special attention to electrode composition, welding technique, and other factors, and involves additional cost.

TIG welding is a welding process that uses a power source, a shielding gas and a TIG hand piece. The power is fed out of the power source, down the TIG hand piece and is delivered to a tungsten electrode which is fitted into the hand piece. An electric arc is then created between the tungsten electrode and the work piece. The tungsten and the welding zone are protected from the surrounding air by a gas shield (inert gas). The electric arc can produce temperatures of up to  $19,400^{\circ}\text{C}$  and this heat can be much focused local heat. The weld pool can be used to join the base metal with or without filler material [1, 2].

**Principle of TIG Welding:** During TIG welding, an arc is maintained between a tungsten electrode and the work piece in an inert atmosphere (Ar, He, or Ar- He mixture). Depending on the weld preparation and the work-piece thickness, it is possible to work with or without filler. The filler can be introduced manually or automatically with regarding to types of process. The process itself can be manual, partly mechanized, fully mechanized or automatic. The welding power source delivers direct or alternating current [6].

#### TIG Welding Equipment:

Four major components make up a GTA welding station. They are the welding power supply, often called the welding machine; the welding torch, often called a TIG torch; the work clamp, sometimes called the ground clamp; and the shielding gas cylinder, Figure 1. There are a variety of hoses and cables that connect all three of these components together [4,5].

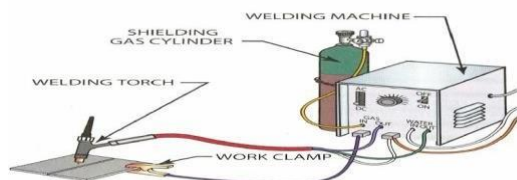

#### Types of welding current used for TIG:

**DCSP - Direct Current Straight Polarity -** (the tungsten electrode is connected to the negative terminal). This type of connection is the most widely used in the DC type welding current connections. With the tungsten being connected to the negative terminal it will only receive 30% of the welding energy (heat). This means the tungsten will

run a lot cooler than DCRP. The resulting weld will have good penetration and a narrow profile.

**DCRP - Direct Current Reverse Polarity -** (The tungsten electrode is connected to the positive terminal). This type of connection is used very rarely because most heat is on the tungsten, thus the tungsten can easily overheat and burn away. DCRP produces a shallow, wide profile and is mainly used on very light material at low amps.

**AC - Alternating Current -** is the preferred welding current for most white

metals, eg aluminum and magnesium. The heat input to the tungsten is averaged out as the AC wave passes from one side of the wave to the other.

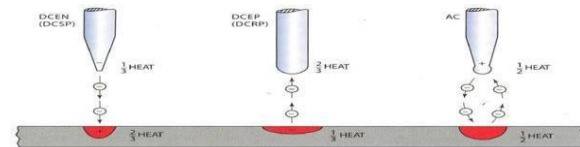

#### Characteristics of current types for gas tungsten arc welding

All three types of welding current can be used for GTA welding. Each current has individual features that make it more desirable for specific conditions or with certain types of metals. The current used affects the heat distribution between the tungsten electrode and the weld and the degree of surface oxide cleaning that occurs. A look at each type and its uses will help the operator select the best current type for the job. The type of current used will have a great effect on the penetration pattern as well as the bead configuration. In Figure 2 above shows the heat distribution for each of the three types of currents [2].

**Direct-current electrode negative:** DCEN, which used to be called direct-current straight polarity (DCSP), concentrates about two-thirds of its welding heat on the work and the remaining one-third on the tungsten. The higher heat input to the weld results in deep penetration. DCEP, which used to be called direct-current reverse polarity (DCRP), concentrates only one-third, of the heat on the plate and two-thirds of the heat on the electrode. This type of current produces wide welds with shallow penetration, but it has a strong cleaning action upon the base metal. The high heat input to the tungsten indicates that large-size tungsten is required, and the end shape with a ball must be used. The low heat input to the metal and the strong cleaning action on the metal make this a good current for thin, heavily oxidized metals.

#### Alternating Current:

Alternating current (AC) concentrates about half of its heat on the work and the other half on the tungsten. Alternating current is continuously switching back and forth between DCEN and DCEP.

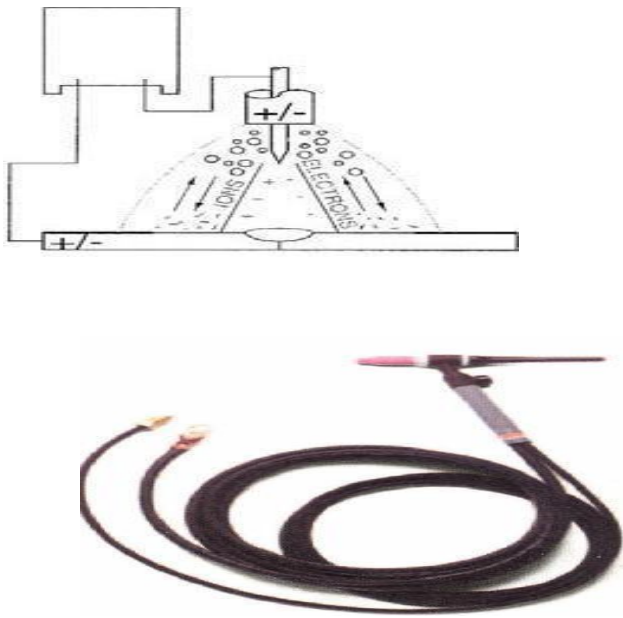

**TIG welding torches:**

TIG welding torches are available water-cooled or air-cooled. The heat transfer efficiency for TIG welding may be as low as 20%. This means that 80% of the heat generated does not enter the weld. Much of this heat stays in the torch. To avoid damage to the torch, the heat must be removed by some type of cooling method. [1]

**TIG Torch Components**

**Collet Body:** The collet body screws into the torch body. It is replaceable and is changed to accommodate various size tungsten's and their respective collets. **Collets:** The welding electrode is held in the torch by the collet. The collet is usually made of copper or a copper alloy. The collet's grip on the electrode is secured when the torch cap is tightened in place. Good electrical contact between the collet and tungsten electrode is essential for good current transfer.

**Nozzles:**

Gas nozzles or cups as they are better known, are made of various types of heat resistant materials in different shapes, diameters and lengths. The nozzles are either screwed into the torch head or pushed in place. Nozzles can be made of ceramic, metal, metal-jacketed ceramic, glass, or other materials. Ceramic is the most popular, but are easily broken and must be replaced often. Nozzles used for automatic applications and high amperage situations often use a water-cooled metal design. Gas nozzles or cups must be large enough to provide adequate shielding gas coverage to the weld pool and surrounding area. A nozzle of a given size will allow only a given amount of gas to flow before the flow becomes turbulent [2].



Ceramic cup or nozzle

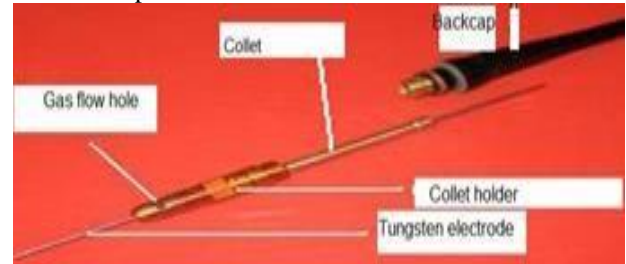

TIG torch components

**Back Caps -** The back cap is the storage area for excess tungsten. They can come in different lengths depending on the space the torch may have to get into (eg. long, medium and short caps).

**Regulators:**

The function of the gas regulator is to reduce bottle pressure gas down to a lower pressure and deliver it at a constant flow. This constant flow of gas flows down through the TIG torch lead to the TIG torch nozzle and around the weld pool. The pressure in the steel cylinders is between

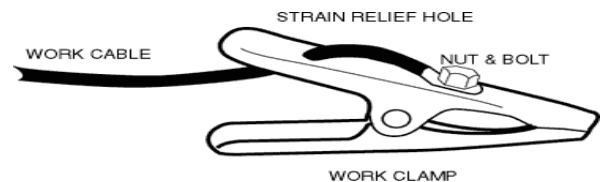

200 and 300 bar. In order to use the shielding gas the high pressure must be reduced to a suitable working pressure.

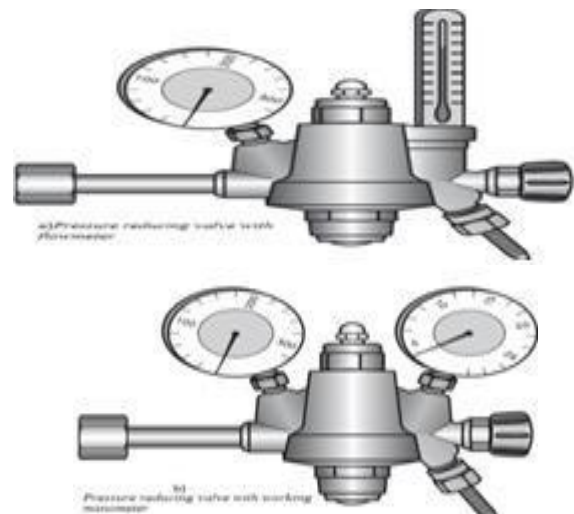

**TIGWelding Machine Ground :**

Welding machines that utilize a flexible cord and plug arrangement or those that are permanently wired into an electrical supply system contain a grounding conductor. The grounding conductor connects the metal enclosure of the welding machine to ground.

If we could trace the grounding wire back through the electrical power distribution system we would find that it is connected to earth, and usually through a metal rod driven into the earth

**Pre-flow and Post-flow :**

The purpose of both pre-flow and post-flow is to prevent contamination of both the weld pool and the tungsten electrode by the surrounding atmosphere.

**Selecting the best tungsten composition:**

To correctly prepare your tungsten electrode for welding you must first select the composition and diameter best suited for your application. Below listed are the 5 most commonly produced tungsten welding electrodes for TIG DC, TIG-AC, and Plasma welding [3]



**Electrode sizes and current capacities:**

Tungsten and Thoriated tungsten electrode sizes and current ranges are listed in Table 5, along with shield-gas cup diameters recommended for use with different types of welding power.

**III. AUTOMATED TIG WELDING, SET UP AND TUNGSTEN ELECTRODE PREPARATION**

**Automated TIG Welding:**

This chapter contains principle of

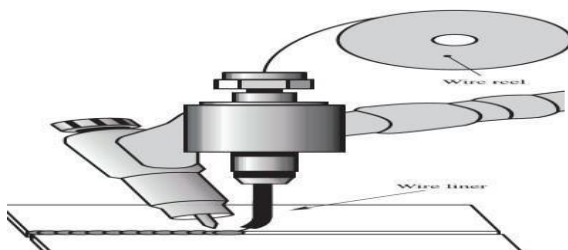

automated TIG arc welding, assembly of

Base Metal Type	Thickness Range	Weld Type	Shield Gas Type	Characteristics
Aluminum Alloys and Magnesium Alloys	Thin	Manual	Pure Argon	Best arc starts, control of penetration, cleaning and appearance on thin gauges.
	Thick	Manual	75 Ar - 25 He	Increase heat input with good arc starts of argon, but with faster welding speeds.
	General Purpose	Manual	Pure Argon	Best overall for good arc starts, control of penetration, cleaning and appearance.
	Thin	Mechanised	50 Ar - 50 He	Higher weld speed under 20mm thick, with good arc stability and starting.
Copper Alloys, Cu-Ni Alloys, Nickel Alloys	Thick	Mechanised	Pure Helium	Highest weld speeds, deeper penetration with DCSP, demanding arc starting and fixturing requirements, high flow rates needed.
	Thin	Manual	Pure Argon	Good control of weld puddle, bead contour, and penetration on thin gauges.
	Thick	Manual	75 Ar - 25 He	Increase heat input with good arc starts of argon, but with faster welding speeds.
	General Purpose	Manual	75 Ar - 25 He	Increase heat input with good arc starts of argon, but with faster welding speeds.
Low Carbon Alloys and Low Alloy Steels	Thick	Mechanised	Pure Helium	Highest weld speeds, deeper penetration with DCSP, demanding arc starting and fixturing requirements, high flow rates needed.
	Thin	Manual	Pure Argon	Best arc starts, control of penetration, cleaning and appearance on thin gauges.

machine, tungsten electrode preparation, operating variables and defects which are the main important things for TIG welding quality are discussed [6].

**CONCLUSION:**

In this case study, we discuss the influence of the power source, type of current, gas flow rate, electrodes, filler wire, TIG Machines settings, and shielding gases which are most important in determine arc stability, arc penetration and defect free welds. To do these a thorough literature survey is carried out on various aspects of the proposed topic, in various peer-reviewed journals, patents, books and other research resources. The prominent results of the present study are summarized below. All the necessary TIG welding principles, equipments, parameters, Shielding gases and tungsten electrodes for welding similar and dissimilar metals work have been explained.

➤ One of the prime considerations for gas tungsten arc welding is the cleanliness of the

equipment, supplies, base metal, filler metal, the welder's gloves, and so forth. When everything is clean, you will find that the welding process proceeds more easily and more successfully.

➤ Another major factor affecting your ability to produce quality welds is the tungsten end or tip shape. When welding on aluminum the tungsten will begin to form a ball, this is perfectly normal. When welding steel the electrode will always stay pointed.

➤ Welding torches available with torch ratings ranging from some tens of A to 450 A, the appropriate rating depending essentially on the thickness of the metal to be welded.

➤ The compositions of filler rods should be chosen to suit the parent metals being welded. The filler rod, if used, should be fed into the leading edge of the weld pool with a slow, „dabbing“ action at an angle of 10–20°. The choice of which welding process was adopted cannot be made lightly because it can significantly impact a company's success both in terms of product costs and the ability to compete successfully in the market with regard to high quality of weld. Manufacturers need to decide many factors in to consideration when determining those TIG welding parameters for their operations.

Automation or mechanization of the TIG process can have a number of benefits. These include the ability to use faster travel speeds, resulting in less distortion and narrower heat affected zones; the better and more consistent control of the welding parameters enables very thin sheet material to be welded; there is a greater consistency in the weld quality; and it is possible to employ operatives with a lesser degree of skill and dexterity than is required for manual welding

#### FUTURE WORK:

This seminar is only a first stop on the road before reaching the end station, i.e. a monitoring system that classifies an ongoing welding process as good or bad weld. Other steps before reaching it could be:

➤ The future study should focus on providing this theoretical Knowledge in to practices to get the desired quality of weld.

➤ To design automated TIG welding machine to reduce weld quality.

➤ Further experiments with TIG welding parameters, using the correct Tungsten electrode that UE uses, the adaptive change of arc length capability turned on and using different surfaces as in this thesis.

#### REFERENCE:

- [1] Larry F. Jeffus (2002). Welding Principles and Applications Publisher Cengage Learning.
- [2] Larry F. Jeffus (2012). Welding and Metal Fabrication Publisher Cengage Learning

- [3] Private Bag (6025). Weldwell New Zealand Napier
- [4] www.Google.Com. TIG welding Hand Book
- [5] Miller: Guidelines for gas tungsten arc welding (GTAW)
- [6] Roshan W.Ttulankar and Suraj
- [7] S. Dehankar: Automation in Sheet Metal Tig Welding Process, International Journal of Engineering Trends and Technology (IJETT) - Volume4 Issue7- July 2013
- [8] Kumar A and Sundarajan S, "Selection of Welding Process Parameters for the Optimum but Joint Strength of an Aluminum Alloy," Material and Manufacturing Process, Vol. 21, No. 8, 2006, pp. 789- 793.
- [9] S. C. Juang and Y. S. Tarn, "Process parameter selection for optimizing the weld pool geometry in the TIG welding of stainless steel," Journal of Material Process Technology, Vol. 122, No. 1, 2002, pp. 33- 37.
- [10] A. A. Mohamed, "Optimization of Weld Bead Dimensions in GTAW of Al-Mg Alloy," Materials and Manufacturing Processes, Vol. 16, No. 5, 2001, pp. 725- 736.
- [11] R. E. Leitner, H. Mcelhinney and E. I. Pruitt, "An investigation of Pulsed Welding Variables," Welding Journal, Vol. 52, No. 9, 1973, pp. 405-410.
- [12] Ugur Esme, Melih Bayramoglu, Yugut Kazancoglu, Sueda Ozgun Optimization of weld bead geometry in Tig welding process using grey relation analysis and taguchi method. Original scientific article/Izvirni znanstveni clanek - 2009, P 143 149.
- [13] Parikshit Dutta, Dilip Kumar Pratihar Modeling of TIG welding process using conventional regression analysis and neural network-based approaches. Journal of Materials Processing Technology 184(2007),P 56–68
- [14] S. Krishnanunni, Dr. Josephkunju Paul C, V Narayanan Unni Effect of Welding Conditions on Hardness of Commercially Pure Titanium Akgec International Journal of Technology, Vol. 3, No. 2, P 19-24.
- [15] Wenchao Dong, Shanping Lu,Dianzhong Li, Yiyi Li GTAW liquid pool convections and the weld shape variations under helium gas shielding.International Journal of Heat and Mass Transfer54(2011), P 1420– 1431.
- [16] Shanping Lu, Hidetoshi Fujii, Kiyoshi Nogia Arc ignitability, bead protection and weld shape variations for He–Ar–O2 shielded GTA welding on SUS304 stainless steel. Journal of materials processing technology 209 (2009), P 1231–1239.