

A Basic Tutorial on Computer Simulation of Phase Controlled Rectifiers Using PSIM

Nagulapati Kiran, M.Tech

Assistant Professor,
Department of EEE
ANITS

Abstract

Simulation is a very powerful tool in various fields of applications. The Software Packages available to simulate Power electronic Circuits are MATLAB, PSPICE and PSIM. This paper will discuss the Simulation of Phase Controlled Converters which include Single Phase Uncontrolled, Semi Controlled and Fully Controlled Rectifiers with R,R-L Load and R-L Load with Free-wheeling Diode, Three Phase Uncontrolled, Fully Controlled Rectifiers are performed in PSIM environment. This paper is basic tutorial to those who are new working in PSIM environment.

1. Introduction

PSIM is a simulation package specially designed for Power Electronics and Control Circuits. It is manufactured by Powersim Inc. It allows fast simulation and has friendly user interface. PSIM is indicated for system-level simulation, control loop design and motor drive system studies. Basic PSIM package consists of three programs: SIMCAD, PSIM and SIMVIEW.

Power Electronics is one the most important area of research of Electrical Engineering. In this field of technology, there are various types of converters. The various converters include single-phase uncontrolled rectifiers, three-phase uncontrolled rectifiers, single phase controlled rectifiers, three-phase controlled rectifiers with R and R-L loads; Single-phase and Three-phase Inverters; Choppers, AC Voltage Controllers and Cyclo converters.

A circuit in PSIM is represented in four blocks. Relationship between these four blocks is shown below

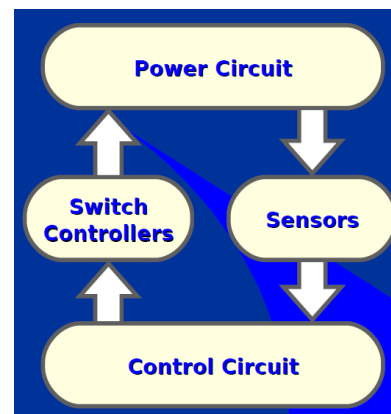

Fig.1 Structure of circuit in PSIM

Power circuit, Control circuit, Switch Controllers and Sensors consists of following components as shown.

Power Circuit	Control Circuit	Switch Controllers	Sensors
<ul style="list-style-type: none"> >Switching devices >RLC branches >Transformers >Coupled inductors 	<ul style="list-style-type: none"> >S-domain blocks >Z-domain blocks >Logic components >Non-linear components 	<ul style="list-style-type: none"> >On-Off controllers >PWM controllers >Alpha controllers 	<ul style="list-style-type: none"> >Current >Voltage >Torque >Speed

Fig 2 Components of Circuit Structure in PSIM

The power circuit consists of switching devices, RLC branches, transformers, and coupled inductors. The control circuit is represented in block diagram. Components in s-domain and z domain, logic components (such as logic gates and flip-flops), and non-linear components (such as multipliers and dividers) are used in the control circuit. Sensors are used to measure power circuit quantities and pass them to the control circuit. Gating signal is then generated from the control circuit and sent back to the power circuit through switch controllers to control switches.

2. Power Electronics Converters

Power Electronic Converters can be converted into five types:

1. Phase controlled rectifiers
2. Inverters
3. Choppers
4. Cyclo converters
5. AC Voltage Regulators

Phase controlled rectifiers convert fixed ac voltage to a variable dc output voltage. These rectifiers use line voltage for their commutation. Hence they are called as line commutated or naturally commutated ac to dc converters. Such converters are widely used for controlling dc drives used at rectifier side of UPS and in HVDC.

Inverters convert a fixed dc voltage into an ac voltage of variable frequency and fixed or variable magnitude. This type of converters use forced commutation to turn off thyristors. Inverters are widely used in induction motors and synchronous motor drives, induction heating, UPS, HVDC and so on.

Choppers convert fixed dc input voltage to variable dc output voltage. They are also referred as dc-dc converters. Choppers find wide applications in dc drives, subway cars, trolley trucks, battery driven vehicles and so on.

Cyclo converters convert input power at one frequency to output power at a different frequency through one stage converters. They are commonly used

for slow speed large ac drives like rotary kilns and traction vehicles.

AC Voltage Regulators convert fixed ac voltage directly to a variable ac voltage at same frequency using line commutation. They are mainly employed for speed control of large fans and pumps.

In this paper Phase controlled rectifiers which include Single-phase/Three-phase Uncontrolled Rectifiers, Single-phase/Three-phase Semi-controlled rectifiers and Single-phase/Three-phase Thyristorized Controlled Rectifiers are simulated using PSIM. This is a basic tutorial of simulating Phase Controlled Rectifiers in PSIM for beginners.

3. Simulink Results

A. Single Phase Half-wave Diode Rectifier with R Load:

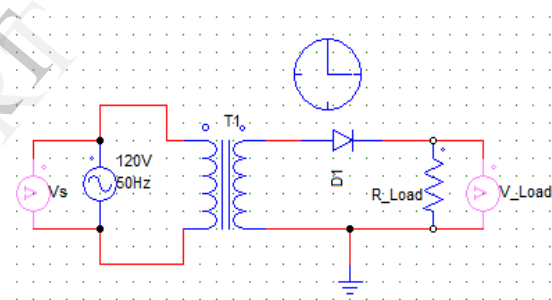

Fig 3. PSIM Circuit of Single-phase half-wave diode rectifier(R_Load)

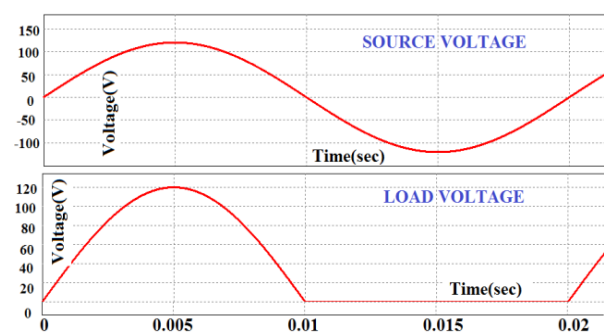

Fig 4. Waveforms of Single-phase half-wave diode rectifier(R_Load)

B. Single Phase Half-wave Diode Rectifier with R-L Load:

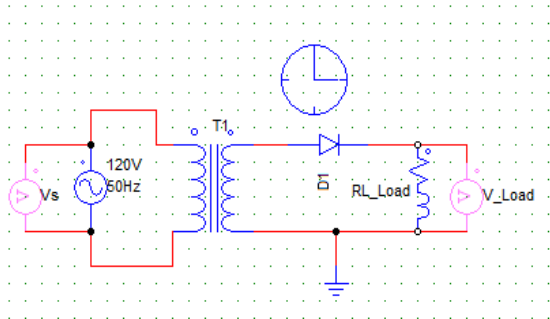

Fig 5 PSIM Model of Single-phase half-wave diode rectifier (RL_Load)

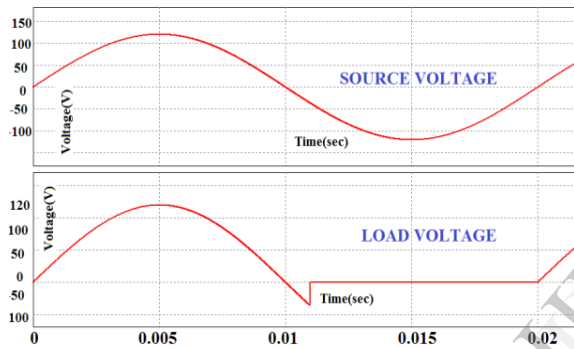

Fig 6. Waveforms of Single-phase half-wave diode rectifier(RL_Load)

C. Single Phase Half-wave Diode Rectifier with R-L Load & Freewheeling Diode:

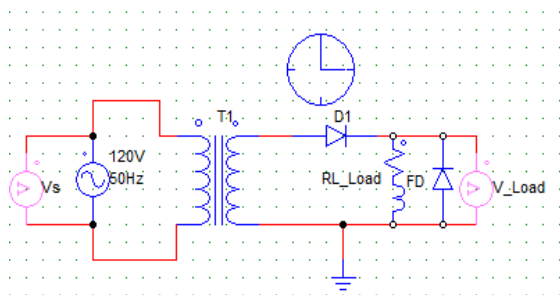

Fig 7. PSIM Model of Single-phase half-wave diode rectifier(RL_Load & Freewheeling Diode)

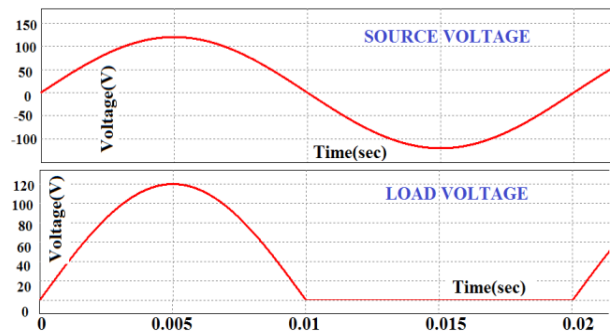

Fig 8. Waveforms of Single-phase half-wave diode rectifier(RL_Load & Free wheeling Diode)

D. Single Phase Full-wave Diode Rectifier with R Load:

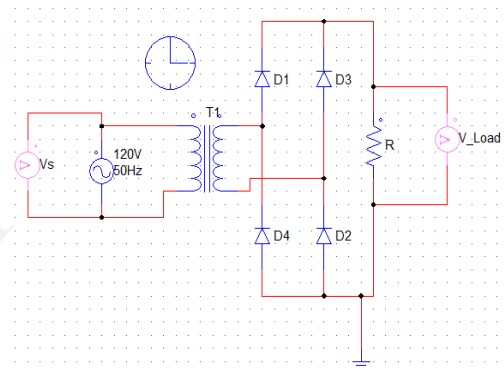

Fig 9. PSIM Model of Single-phase Full-wave diode rectifier(R_Load)

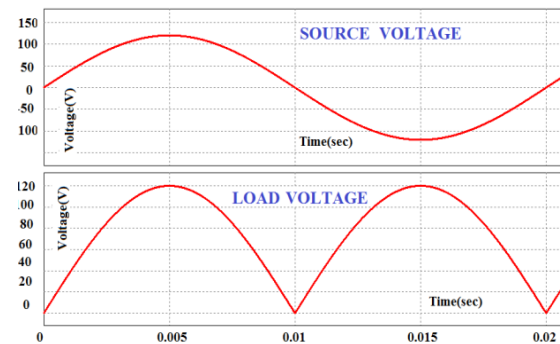

Fig 10. Waveforms of Single-phase Full-wave diode rectifier(R_Load)

E. Single Phase Full-wave Diode Rectifier with R-L Load:

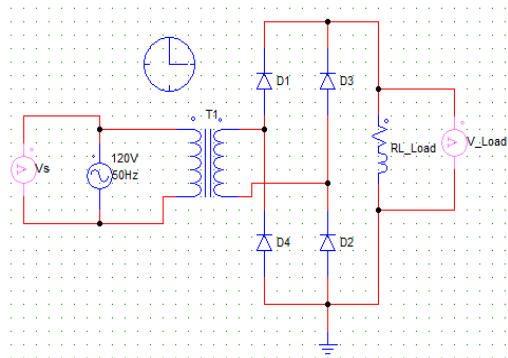

Fig 11. PSIM Model of Single-phase Full-wave diode rectifier(RL_Load)

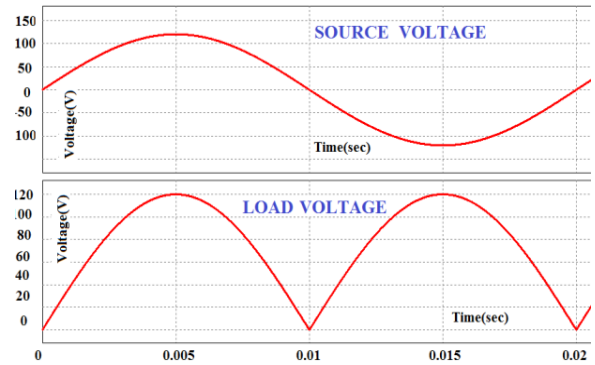

Fig 14. Waveforms of Single-phase Full-wave diode rectifier(RL_Load and Free-wheeling Diode)

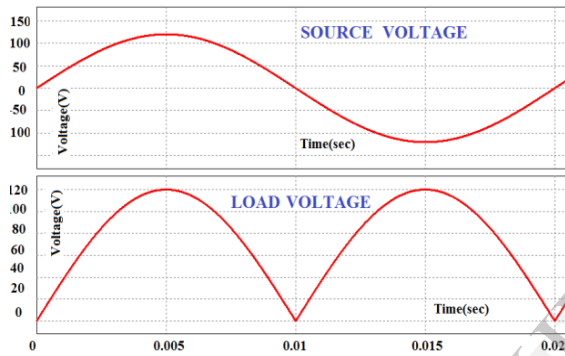

Fig 12. Waveforms of Single-phase Full-wave diode rectifier(RL_Load)

G. Three Phase Half-wave Diode Rectifier with R Load

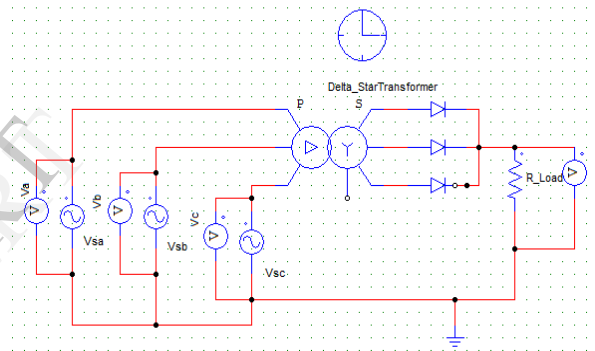

Fig 15. PSIM Model of Three-phase half-wave diode rectifier with R Load

F. Single Phase Full-wave Diode Rectifier with R-L Load & Freewheeling Diode:

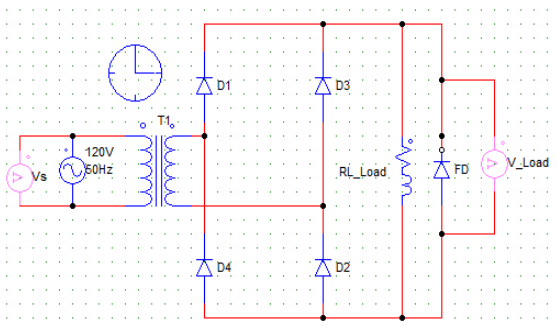

Fig 13. PSIM Model of Single-phase Full-wave diode rectifier(RL_Load and Free wheling Diode)

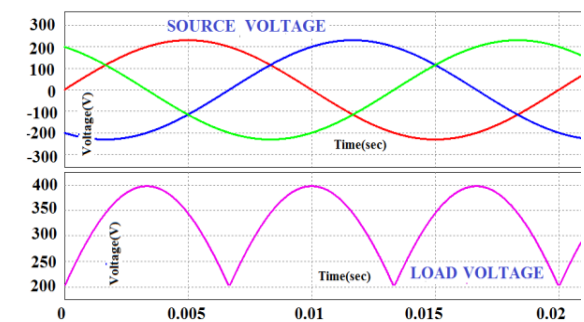

Fig 16. Waveforms of Three-phase half-wave diode rectifier with R Load

H. Three Phase Six-Pulse Diode Bridge Rectifier with R Load

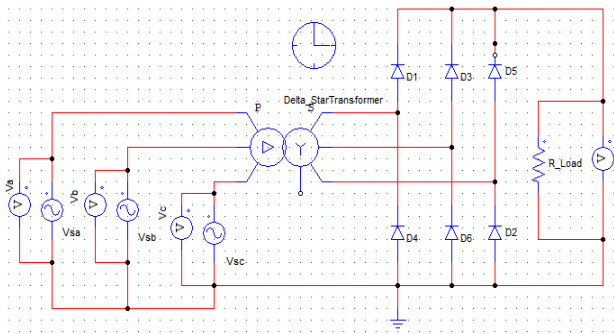

Fig 17. PSIM Model of Three Phase Six-Pulse Diode Bridge Rectifier with R Load

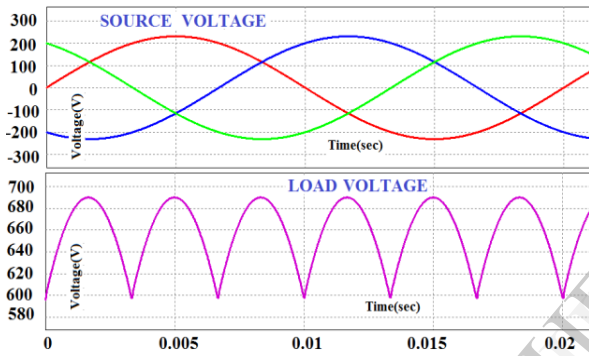

Fig 18. Waveforms of Three Phase Six-Pulse Diode Bridge Rectifier with R Load

I. Single Phase Half wave Controlled Rectifier with R Load

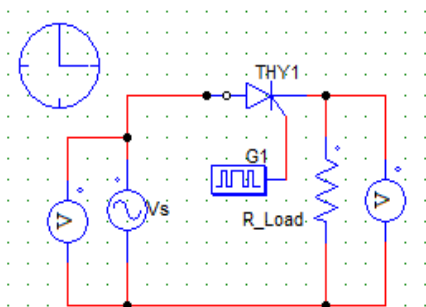

Fig 19. PSIM Model of Single-phase half-wave controlled rectifier(R_{Load})

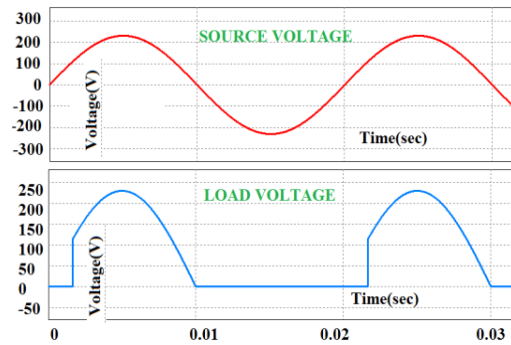

Fig 20. Waveforms of Single-phase half-wave controlled rectifier(R_{Load})

J. Single Phase Half wave Controlled Rectifier with RL Load

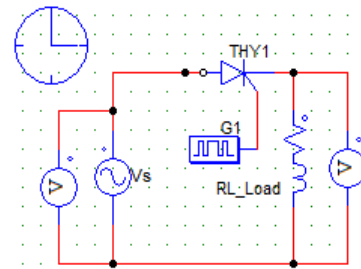

Fig 21. PSIM Model of Single-phase half-wave controlled rectifier(RL_{Load})

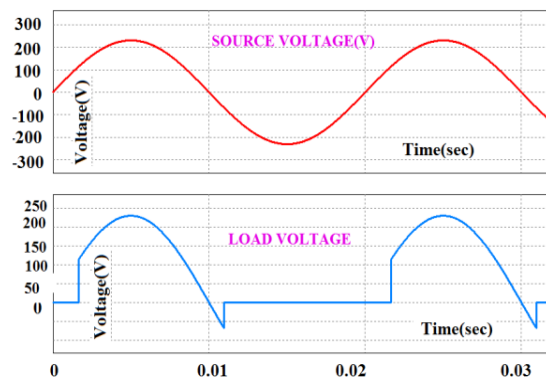

Fig 22. Waveforms of Single-phase half-wave controlled rectifier(RL_{Load})

K. Single Phase Half wave Controlled Rectifier with RL Load and Free-wheeling Diode

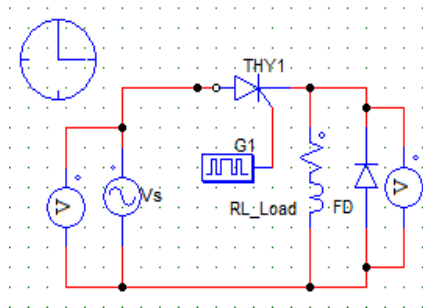

Fig 23. PSIM Model of Single-phase half-wave controlled rectifier(RL_Load and Freewheeling Diode)

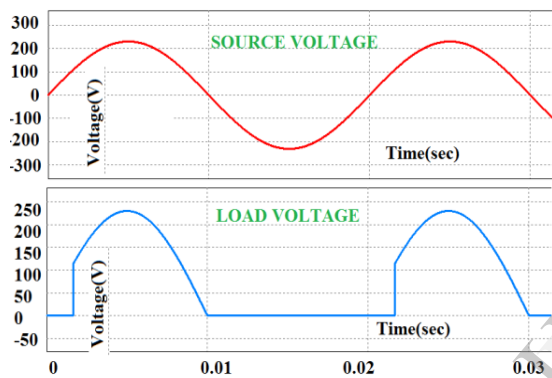

Fig 24. Waveforms of Single-phase half-wave controlled rectifier(RL_Load and Freewheeling Diode)

L. Single Phase Full wave Controlled Bridge Rectifier with R Load

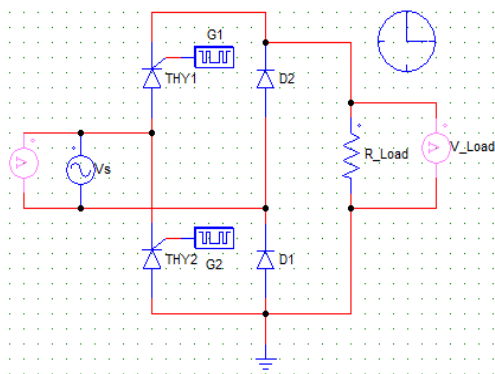

Fig 25. PSIM Model of Single-phase Full-wave controlled Bridge rectifier(R_Load)

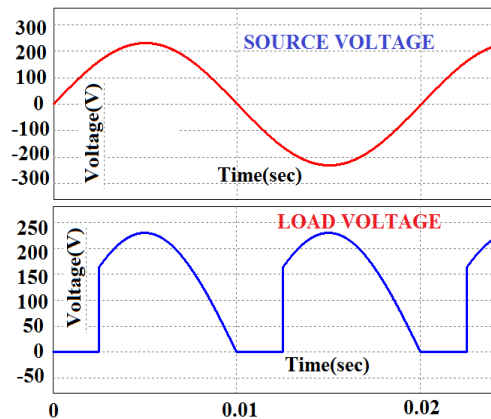

Fig 26. Waveforms of Single-phase Full-wave controlled Bridge rectifier(R_Load)

M. Single Phase Full wave Controlled Bridge Rectifier with R-L Load

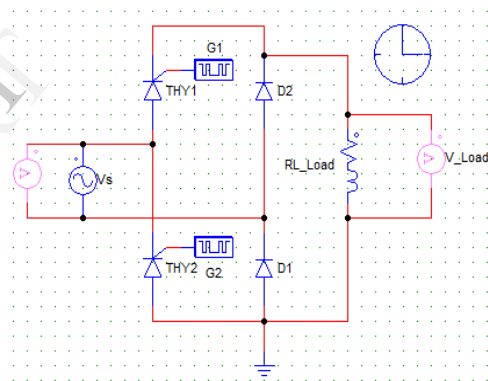

Fig 27. PSIM Model of Single-phase Full-wave controlled bridge rectifier(RL_Load)

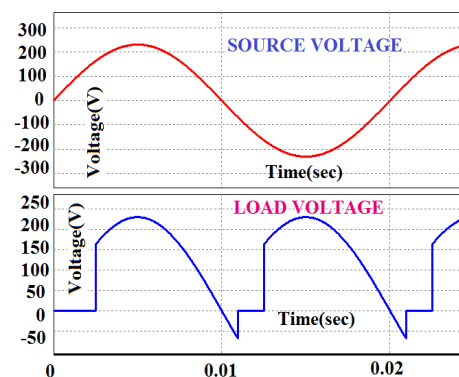

Fig 28. Waveforms of Single-phase Full-wave controlled Bridge rectifier with RL_Load(Discontinuous Mode)

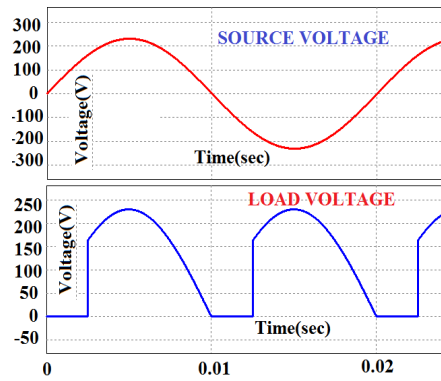

Fig 29. Waveforms of Single-phase Full-wave controlled Bridge rectifier with RL_Load(Continuous Mode)

N. Single Phase Full wave Controlled Bridge Rectifier with R-L Load and Free-wheeling Diode

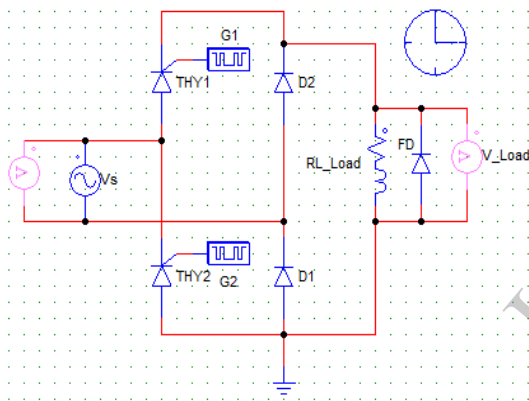

Fig 30. PSIM Model of Single-phase Full-wave controlled Bridge rectifier(RL_Load & Free-wheeling Diode)

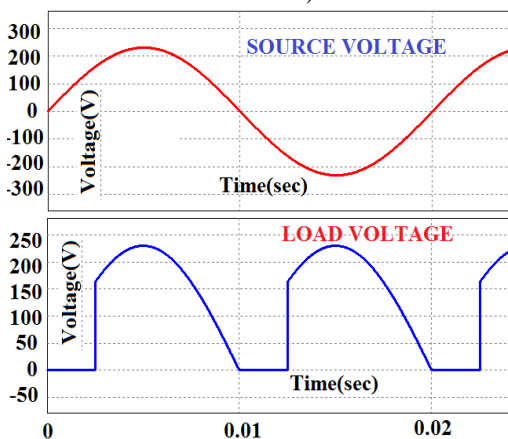

Fig 31. Waveforms of Single-phase Full-wave controlled bridge rectifier(RL_Load and Freewheeling Diode)

O. Three Phase Full wave Controlled Bridge Rectifier with R Load

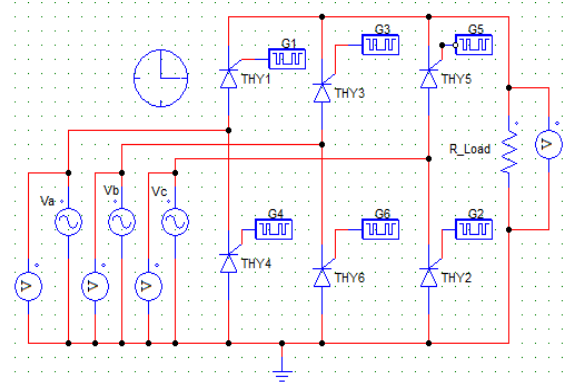

Fig 32. PSIM Model of Three-phase Full-wave controlled Bridge rectifier(RL_Load and Free-wheeling Diode)

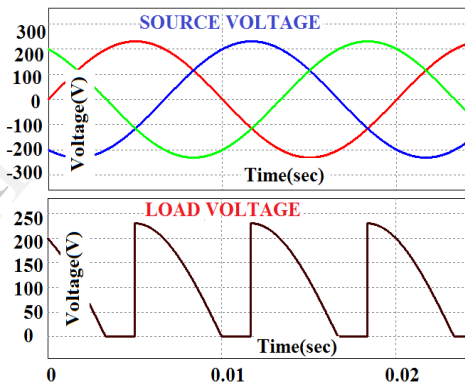

Fig 33. Waveforms of Single-phase Full-wave controlled Bridge rectifier with R_Load

A. P. Three Phase Full wave Controlled Bridge Rectifier with R-L Load

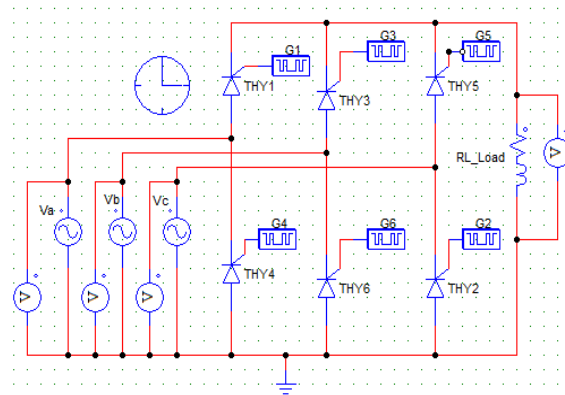

Fig 34. PSIM Model of Single-phase Full-wave controlled Bridge rectifier(RL_Load)

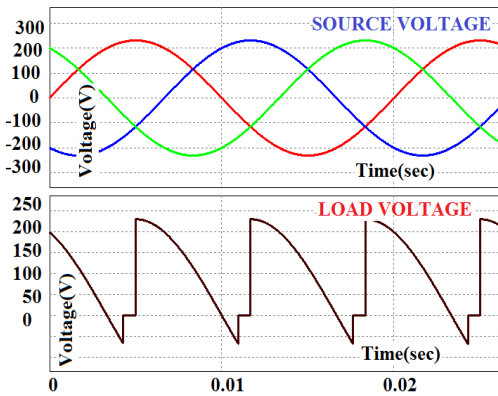

Fig 35. Waveforms of Single-phase Full-wave controlled Bridge rectifier with RL_Load (Discontinuous Mode)

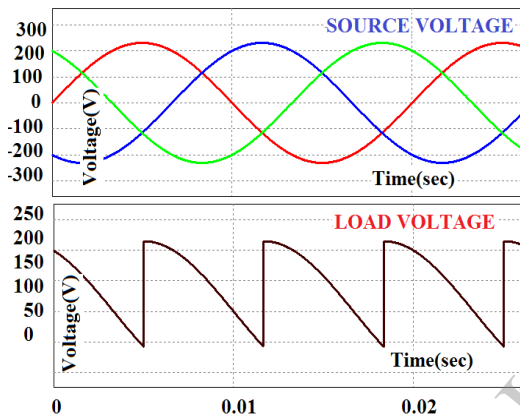

Fig 36. Waveforms of Single-phase Full-wave controlled Bridge rectifier with RL_Load (Continuous Mode)

Q. Three Phase Full wave Controlled Bridge Rectifier with RL Load and Freewheeling Diode

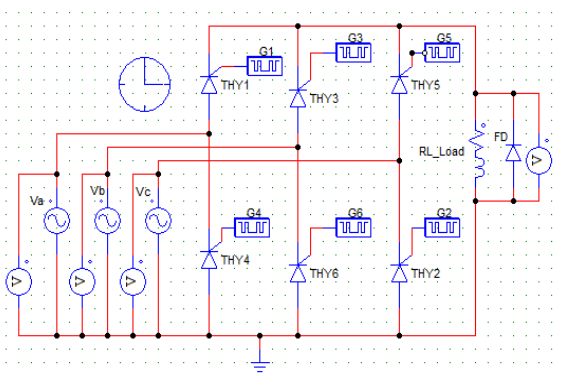

Fig 37. PSIM Model of Three-phase Full wave Controlled Bridge Rectifier (RL_Load and Free wheeling Diode)

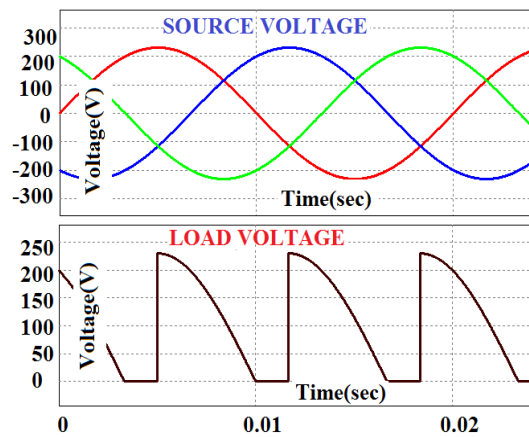

Fig 38. Waveforms of Three-phase Full wave Controlled Bridge rectifier (RL_Load and Free wheeling Diode)

R. Single Phase Semi Controlled Bridge Rectifier with R Load

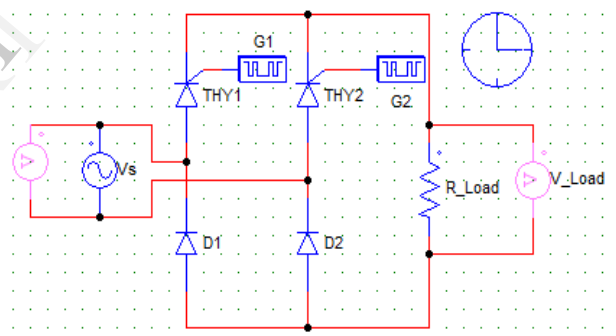

Fig 39. PSIM Model of Single-phase Semi Controlled Bridge Rectifier (R_Load)

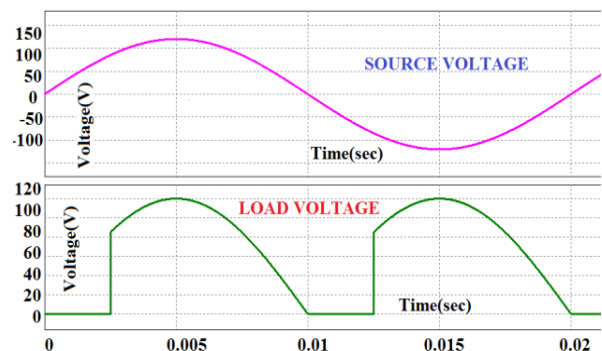

Fig 40. Waveforms of Single-phase Semi Controlled Bridge Rectifier (R_Load)

S. Single Phase Semi Controlled Bridge Rectifier with RL Load

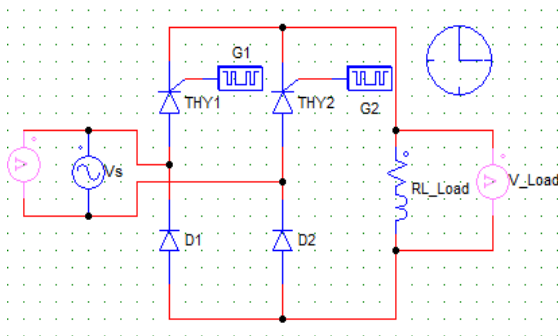

Fig 41. PSIM Model of Single-phase Semi Controlled Bridge rectifier(RL_Load)

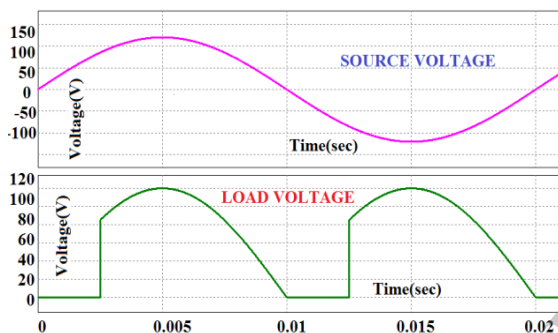

Fig 42. Waveforms of Single-phase Semi Controlled Bridge rectifier(RL_Load)

T. Single Phase Semi Controlled Bridge Rectifier with RL Load and Free wheeling Diode

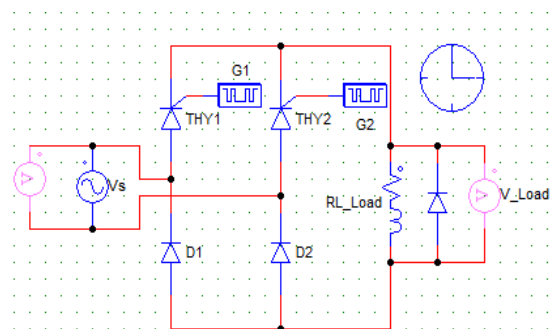

Fig 43. PSIM Model of Single-phase Semi controlled bridge rectifier(RL_Load and Freewheeling Diode)

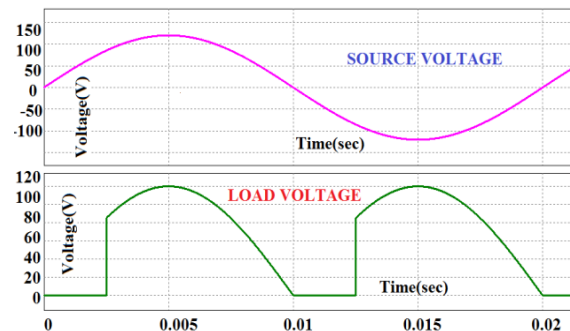

Fig 44. Waveforms of Single-phase Semi controlled bridge rectifier(RL_Load and Freewheeling Diode)

4. Conclusion

Phase Controlled Rectifiers are simulated in PSIM environment which include Single Phase Uncontrolled, Semi Controlled and Fully Controlled Rectifiers with R, R-L Loads and R-L Load with Free-wheeling Diode, Three Phase Fully Controlled Rectifiers with R, R-L Loads and R-L Load with Freewheeling Diode.

This paper is a Basic Tutorial on how to simulate Power Electronics circuits in PSIM environment.

5. References

- [1] Bhimbra, P. S., Power Electronics, 4th Ed., Khanna Publication, 2007.
- [2] Synchronous Current control Scheme with reference voltage inverter J. W. Jung, K. Y. Cho, D. S. Oh and M. J. Young
- [3] PowerSim User Manual
- [4] <http://www.powersimtech.com>
- [5] P.J. van Duijsen; P. Bauer; B. Davat; "Simulation and Animation of Power Electronics and Drives, Requirements for Education" [Online]. Available: www.simulation-research.com
- [6] Santosh S. Raghuvanshi, Ankita Singh, Yamini mokhariwale, "A Comparison & Performance of Simulation Tools MATLAB/SIMULINK, PSIM & PSPICE for Power Electronics Circuits", International Journal of Advanced Research in Computer Science and Software Engineering, Volume 2, Issue 3, March 2012
- [7] Hemant Mehar, "MATLAB Simulation Techniques in Power Electronics", IEEE Technology and Engineering Education (ITEE), VOL. 7, NO.4 December, 2012, Page No. 62.
- [8] Prof. Sabyasachi Sengupta and et.all, "NPTEL Power Electronics Notes" [Online]. Available: nptel.iitm.ac.in

- [9] Mohan, Undeland, Robbins, *Power Electronics: Converters, Applications and Design, 2nd Edition*. New York: John Wiley & Sons INC., 1995
- [10] Hemant Mehar, "Software Application In Under Graduate Electrical Engineering Education", *International Journal of Engineering Research & Technology (IJERT)*, Vol. 1 Issue 10, December- 2012)
- [11] N. Mohan, T. Undeland, W. Robbins, *Power electronics: Converters, applications and designs*, John Wiley and Sons, 1989
- [12] BK khanchandani, *Power electronics*, Tata McGraw-Hill publishing company, 2008
- [13] Chung Kuo, Jack Hsieh, Firuz Zare, Senior Member IEEE, Gerard Ledwich, Senior Member IEEE "An Interactive Educational Learning Tool for Power Electronics" Conf. Power Engineering, 2007 Australasian Universities, AUPEC 2007
- [14] Sameer Khader "The Application of PSIM & MATLAB/SIMULINK in power electronics courses", Conf. "Learning Environments and Ecosystems in Engineering Education"; IEEE Global Engineering Education Conference (EDUCON) – April 4 - 6, 2010, Amman, Jordan
- [15] Palit, S.K., Voumard, P. and Ito, K., *Electrical and electronic engineering education in the Asia-Pacific Region. Proc. 1st Asia-Pacific Forum on Engng. and Tech. Educ., Monash University, Melbourne, Australia, 153-157 (1997).*
- [16] P.C. Sen, *Power electronics*, Tata McGraw-Hill publishing company, 2008
- [17] Martins M.J., M. Robert and J.M. Thiriet, "A thematic network contribution to education and training in electrical and information engineering in Europe", 4th ITHET'03 Conference, Marrakech, Morocco, 2003 July 7-9 (CD-ROM).
- [18] Palit, S.K., and Reid, M, Application of Pspice in the teaching of undergraduate electronics. *Proc. Pacific Region Conf. on Electrical Engng. Educ. (PREEE,97)*, Wollongong University, NSW, Australia, 181-186 (1997).
- [19] Thiriet J.M., M. Robert, P. Lappalainen, M. Hoffmann, M. J. Martins and A. Seoane, "Toward a pan-European virtual university in Electrical and Information Engineering", *IEEE Trans. On Education*, Vol.45, n. 2, May 2002, pp.152-160.