

# A New Quadruples E-Core Transformer To Minimize Output Ripple Current

Herawati Yusuf

## Abstract

A new quadruples E-transformer made of ferrite is proposed in this paper. In order to control magnetic flux ( $\psi$ ) in the ferrite with coil in the primary and secondary core transformer, wire coil should be twisted  $50^\circ$  with tiny air gap, resulting in higher efficiency. However, it should be suitable to heavy system loads. Otherwise, it will influence the duty cycle, and it will create ripple current for about 10 percents. The fixed air gap should be evaluated with respect to magneto motive (mmf), as one of their electromagnetic field sources in the system. In addition, the adjusted magnetic flux ( $\psi$ ) also can be controlled by inserting air gaps, and the magnetic flux can be justified by varying the width of gap.

In this experiment six air gaps are inserted in the quadruples E-transformer. The coil is composed of a ring wire gauge in which each ring wire gauge has radius  $r$  is 0.0004 m give the ripple current 0.036%. So The New quadruples E-transformer help greatly to make system more stable.

**Keywords:** Boost converter, E type ferrite, geometry, air gap, gyrator-capacitor, low ripple current.

## 1. Introduction

Nowadays, a lot of industry activities such as electroplating and chemical processing require a good electrical system which has low ripple current since that ripple current could causes losses and disturb the output of the process. The ripple current from an electrical system usually treated as a noise and it has to be limited e.g. in chemical processing, the permitted ripple current is 3% but basically the smaller noise, the better system. Experiment hypothesis later on sees that ripple current could be reduced significantly by using the gyrator-capacitor [1] and twisting the winding of conductors [2].

The equivalent electric circuit approached from the modification is resulting new quadruples E transformation as total capacitor [3], where magnetic networks using the ferrite core. The ferrite become parasitic capacitor or inductor which simultaneous to counter the variable loads. It becomes simultaneous switching noise [4]. The properties of ferrite are lumped so there are no losses [5]. Also the air gap is generating magnetic

flux [6]. Actually, interposed air can be utilized as a controller of input and output mmf and even some more technologies applied could be controlled the automatic system.

This paper proposed Cuk converter Slobodan with transformer four E type core, six air gap and twisted winding as new quadruples E core transformer to minimize the output ripple current.

## 2. Quadruples E-transformer design

### 2.1. The Model quadruples core E Type with six air gap and a couple winding

This paper is using a new quadruples E transformation modeled as the total capacitance approach and magnetic source as gyrator.

Gyrator is a coil that analyze through approach on magnetic circuit to electric circuit [1], which the core have been applied to the coils system. Gyrator must be paired to each other, so that it can make an optimal result that creates the electromagnetic coupling like the ideal transformer ones [2].

Gyrator must be applied in boost converter Cuk Slobodan and put it in second core magnetic E type [3] as a universal in load resistance as seen in Figure 1, and it will get the percentage of output ripple current about 0.036 %.

Gyrator in Cuk Converter can reduced the ripple less than 3%. With parallel RLC load, the ripple could make it up to only 0.036%. The magnetic core type must be at quadruples range as seen in Figure 1.

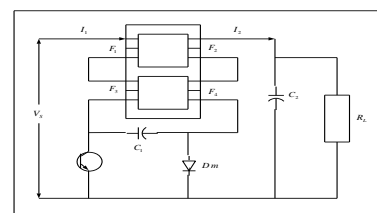

**Figure 1. Modification boost Converter and quadruples E Type with six air gap.**

The Cuk converter in Figure 1 is still loaded by resistance ( $R$ ). Modification boosts Converter with second E Type with four air gap about 0.036%. If the RLC load, the ripple current becomes more than 3%. It must be redesign with quadruples E-transformer with six air gap [3].

## 2.2. New approaching parameter in electric quadruples E-core transformer

The proposed geometry of quadruples E-transformer is shown in Figure 2.a. The structure geometry core of quadruples E-type is ferromagnetic which is composed as shown in the Figure 2. Air gaps are in structure between quadruples of E-type. The dimension is adjusted to obtain the best performance.

Based on Figure 1, the Cuk Converter could be analyzed by using a boost converter with 9 volt input [4], The air gap cross-section at each base is 1 mm. The geometry of Figure 2.a. is provided in table 1.

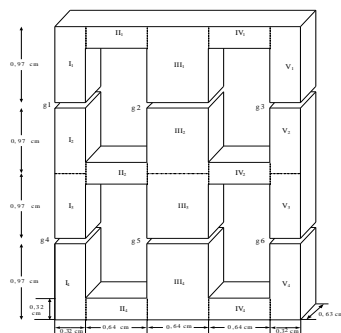

(a)

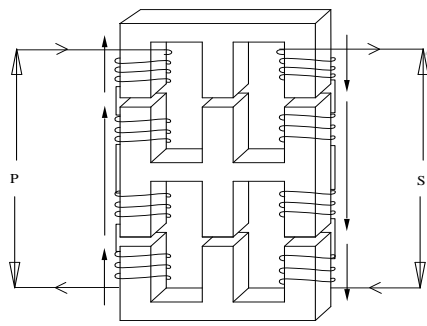

(b)

Figure 2. Geometry and coil winding on ferritecore transformer.

(a) Transformer with air gap.

(b) Geometry of E core Type with 6 air gaps.

Table 1. Reluctance and Permeance from a part 1 transformer.

Part of Geometry E type	Long Race (cm)	Cross-section area (cm <sup>2</sup> )	Reluctance (AT/Wb)	Permeance (H)
Left Foot Core I <sub>1</sub>	1	0.18	0.442 10 <sup>6</sup>	2.262 10 <sup>6</sup>
Part II <sub>1</sub> Core	0.6	0.18	0.265 10 <sup>6</sup>	3.773 10 <sup>6</sup>
Middle Foot core III <sub>1</sub>	1	0.36	0.221 10 <sup>6</sup>	4.524 10 <sup>6</sup>

Part IV <sub>1</sub> Core	0.6	0.18	0.265 10 <sup>6</sup>	3.773 10 <sup>6</sup>
Right Foot Core V <sub>1</sub>	1	0.18	0.442 10 <sup>6</sup>	2.262 10 <sup>6</sup>
Left Foot Core I <sub>2</sub>	1.42	0.4185	0.0270.10 <sup>6</sup>	37.017.10 <sup>6</sup>
Part II <sub>2</sub> Core	0.9	1.488	0.0024.10 <sup>6</sup>	415.317.10 <sup>6</sup>
Middle Foot core III <sub>2</sub>	1.42	0.8742	0.0129.10 <sup>6</sup>	77.324.10 <sup>6</sup>
Part IV <sub>2</sub> Core	0.9	1.488	0.0024.10 <sup>6</sup>	415.317.10 <sup>6</sup>
Right Foot Core V <sub>2</sub>	1.42	0.4185	0.0270.10 <sup>6</sup>	37.017.10 <sup>6</sup>
Left foot of core Trafo I <sub>3</sub>	1.42	0.4185	0.0270.10 <sup>6</sup>	37.017.10 <sup>6</sup>
Right foot of middle core Trafo III <sub>3</sub>	1.42	0.8742	0.0129.10 <sup>6</sup>	77.324.10 <sup>6</sup>
Right foot of core V <sub>3</sub>	1.42	0.4185	0.0270.10 <sup>6</sup>	37.017.10 <sup>6</sup>
Left Foot Core I <sub>4</sub>	1.42	0.4185	0.0270.10 <sup>6</sup>	37.017.10 <sup>6</sup>
Part II <sub>4</sub> Core	0.45	0.744	0.0048.10 <sup>6</sup>	207.659.10 <sup>6</sup>
Middle Foot core III <sub>4</sub>	1.42	0.8742	0.0129.10 <sup>6</sup>	77.324.10 <sup>6</sup>
Part IV <sub>4</sub> Core	0.45	0.744	0.0048.10 <sup>6</sup>	207.659.10 <sup>6</sup>
Right Foot Core V <sub>4</sub>	1.42	0.4185	0.0270.10 <sup>6</sup>	37.017.10 <sup>6</sup>

The calculation results of all Part of geometry in Figure 2.b. [3], like reluctance and permeance .The core and air gaps can be derived by magnetic material approach into the electric network [3], reluctance [6], capacitance and permeance [3]. The geometry of Figure 1 and the reluctance calculation (7) are provided in table 1.

Refers to Figure 3, the calculation involves all parameter values including for substituting the air gap and reluctance calculations are noted into Table 2. The air gap 1, 2, 3, 4, 5 and 6 are same. Because of the same, so all the air gap table is similar with table 2.

Table 2. Assess Reluctance and Permeance of air gap 1 up to six.

Air Gap1 (mm)	Cross section area (cm <sup>2</sup> )	Reluctance (AT/Wb)	Permeance (H)
0.1	0.18	0.00442 109	226.244 10-9
0.2	0.18	0.00884 109	113 10-9
0.3	0.18	0.0132 109	75.75 10-9
0.5	0.18	0.0221 109	45.24 10-9
0.6	0.18	0.0265 109	37.73 10-9

Variable total capacitance and variable air gap could be showed in figure 3.

GRAPHIC OF TRANSFORMATOR'S CORE

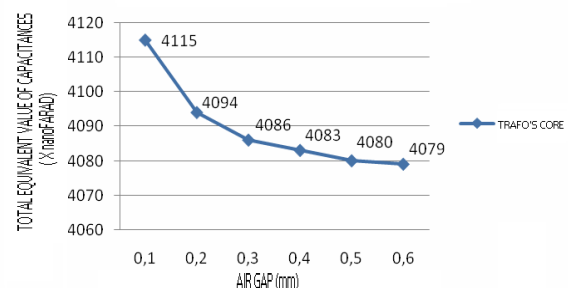

**Figure 3. The relation of total capacitance in new quadruples with six air gap.**

### 3. A new quadruples E-core transformer as gyrator-capacitor in Cuk Slobodan Converter.

#### 3.1. Magneto motive force as Gyrator

The windings are evaluated as three conductors or two connected polar tide approach of electric network and magnetic network [3]. The voltage and the current equations (1 and 2) represent the interaction between electric field and magnetic field which can be seen on Figure 4. It is a quadruples-port polar electric network with hybrid parameter [5].

Based on Figure 2a, the primary voltage winding  $V_1$  depend on the current on secondary is obtained by equation 1, and vise versa the voltage winding of secondary which  $V_2$  depend on the current input of source is approached by magnetic circuit to electric circuit [1].

$$\begin{aligned} V_1 &= r \cdot i_2 \\ V_2 &= r \cdot i_1 \end{aligned} \quad \text{and} \quad (1)$$

Voltage Control Current Source (VCCS) where  $1/r$  is gyrator, described as equation 3 below:

$$\begin{aligned} I_1 &= g V_2 \\ I_2 &= g V_1 \end{aligned} \quad \text{and} \quad (2)$$

Where:

$V_1$  = input Voltage (V)

$V_2$  = output Voltage (V)

$r$  = the resistance of Gyrator (Ohm)

$g$  = gyrator (mho)

$f$  = frequency (Hz)

$L$  = Inductance (Henry)

The implementation of modified equation is [1]:

$$g = \frac{1}{R} \quad (3)$$

All parameters are calculated using Psim-val simulation. By substituting equation (1) and (2) into equation (3), the output ripple current in Cuk converter Figure1. is obtained by the equation 4.

$$\Delta I_2 = \frac{-V_a(1-k)}{f L_2} = \frac{k V_a}{f L_2} \quad (4)$$

The VCCS and the CCVS configuration can be seen, respectively, on Figure 4a for Gyrator at

primary side and Figure 4b. For air gap core coil Gyrator at secondary side.

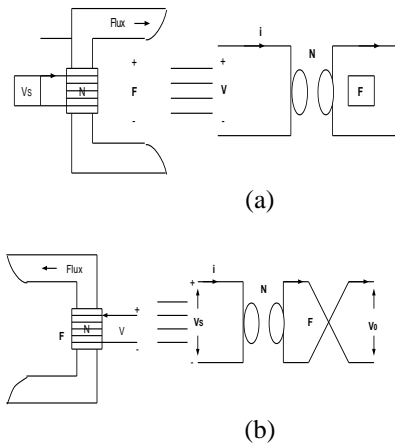

**Figure 4.(a) Gyrator model of transformer in primary and (b) Gyrator model side of secondary of the transformer.**

#### 3.2. Gyrator - Capacitor model could Reduce output ripple current of Cuk Converter.

From the Table 1 and table 2, the total capacitance and gyrator model in Figure 4 a and b. could be integrated, like shown in Figure 5.

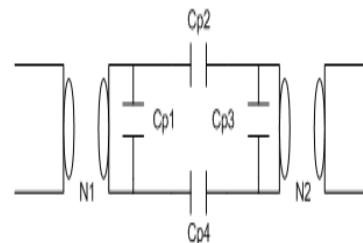

**Figure 5. The Gyrator - Capacitor model.**

Gyrator-Capacitor model Figure 5. could be integrated with boost converter Cuk Slobodan in Figure 1. because four E core type and six air gap was modify with the model of gyrator-capasitor. It can be seen as Figure 6.

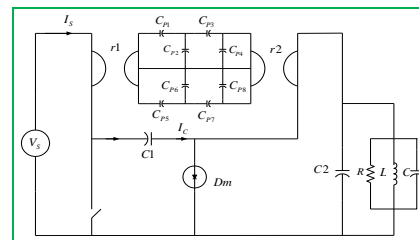

**Figure 6. Quadruple E-transformer in Cuk Converter Slobodan**

### 4. Simulation and experiment.

### 4.1. Simulation

The experiment uses 1 – 6 mm variable air gaps in the permanent magnetic cores, which results in the best performance at 4 mm, constructed by 3 coil windings and twisted at 50°. By designing the load, we could find that the gyrator resistance will stabilize the load changing. Also, through the simulation it could be seen that the smaller gyrator resistance, the smaller magnetic resistance and capacitance.

We find the resistance of gyrator from the total approach of capacitance of ferrite material and air gap,  $R_G$  at Table 1 and 2. For  $R_G = 0.2 \text{ Ohm}$  and the output current ripple about 2 % in Figure 8.a. for full load.

for  $R_G = 0.0128 \text{ Ohm}$ , result in the output ripple 1.6 %. This is the same as Figure 8.b. that the resistance gyrator is about 0.098 ohm.

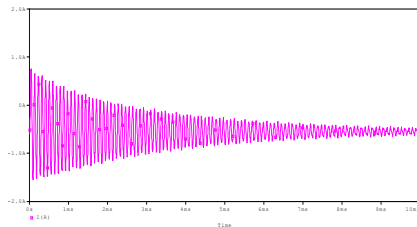
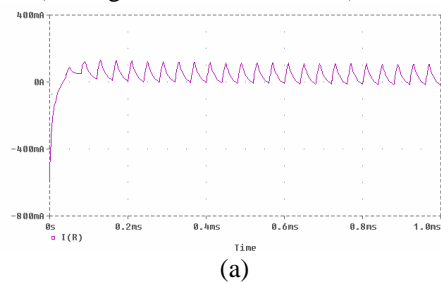
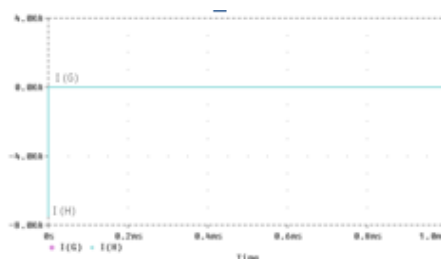

Figure 7. The output ripples current before modification.

Later on, it found that the total gyrator resistance must be suitable to material, air gap and coil winding. With that kind of total gyrator resistance, the ripple could be reduced into 0.036 % (as long as the load is normal).



(a)



(b)

Figure 8. The graph of Current Gyrator  $I_G$  and current hybrid  $I_H$  respect to time for

$R_G = 0.0128 \text{ Ohm}$ .

- (a) The output ripple current more than 2 % with RLC load and double E-transformer.
- (b) The output ripple current 0.36 % With RLC load and quadruples E-Transformer (Pspice simulation).

On Figure 8.b, the output current ripple is 0.36% for gyrator-capacitor. After calculating the twisted winding, it produces smaller ripple and makes the system more stable, like Figure 8.b. The efficiency is 99.8%.

### 4.2. Experiment

The experiment on Figure 9 could be seen both with and without air gap. The first time experiment held with air gap.

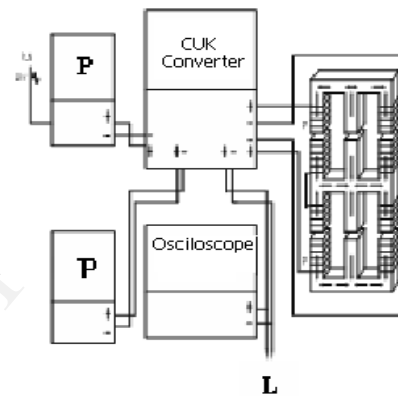
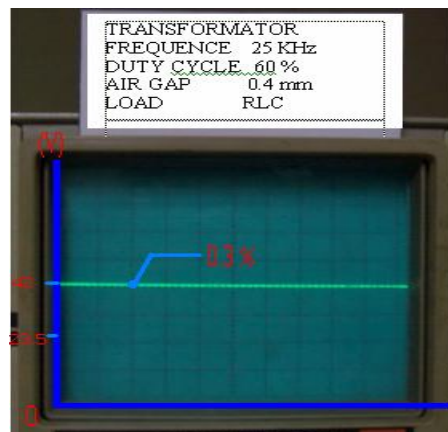

Figure 9. Block Diagram experiment of Quadruple E-transformer in Cuk Converter Slobodan.

The output voltage increasing until 21 Volt on RLC load. The air gap is about 0.4 mm with output ripple 0.36%. see Figure 10a.

The second experiment then was the one without air gap condition. The output ripple current turned into less than 1% but the output voltage is 12 Volt (Fig. 10b).



(a)

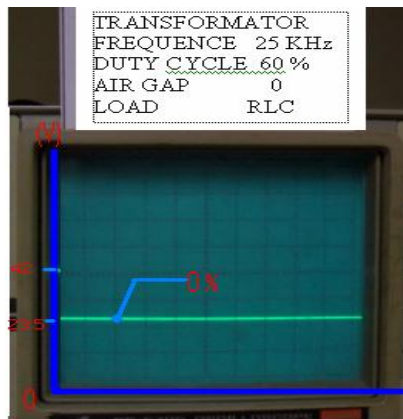

(b)

**Figure.10. Experiment of Quadruple E core transformer in Cuk Converter Slobodan.**  
(a) with air gap, and (b) without air gap.

Figure 11 will shows many variable load and no load, the best air gap in 1 mm or 3 mm air gap. If more than 1mm the voltage will be decrease until more than 2mm the voltage will increased become maximal voltage 34 Volt in 3 mm for frequency 25 KHz for RLC load.

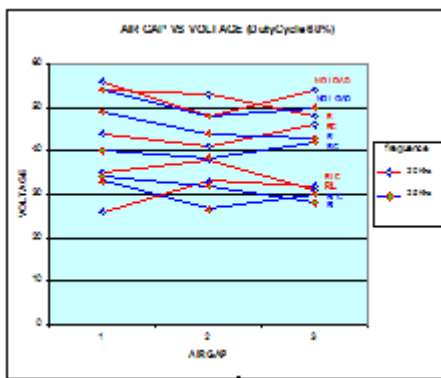

**Figure 11. Graphic Air gap Vs Voltage at frequency 20 KHz and 25 KHz.**

In Figure 11. The variable load R, L, C, RL, RC, and RLC load on frequency 20 KHz and 25 KHz. With 60% duty cycle. in frequency 25 KHz with air gap 0.3 mm on load RLC the voltage increase but on 20 KHz With 60% duty cycle in air gap 0.3 mm the voltage load decreased.

## 5. Discussion.

Based on the simulation, it can conclude that the resistance of gyrator could change the output ripple; the less resistance of gyrator would make

the less output of ripple current, where shown at the calculation of the capacitance parameter approach from the geometry of magnetic core. In the other hand, experiment shows that the voltage is increasing when it loaded by RLC loads, both for with and without air gap. Air gap could be increase the voltage about 18.5 Volt (see Figure 10.a and 10.b.), if the air gap of Quadruple E core transformer in Cuk Converter Slobodan load condition about 0.4mm on RLC load.(in experiment), in PSpice simulation the air gap could be increase the voltage about four Volt. The optimal air gap about 0.4 mm, duty cycle 60 on RLC load. The output ripples current about 0.36%. on RC, RL load condition the ripple more than 1%. The experiment could increase the voltage higher then simulation on RLC load.

In the simulation and experiment, almost show the same output ripple current.

## 6. Conclusion

By making the air gap equal to 4 mm in the six air gaps, the best output performance is achieved. The modeled of quadruples E-type ferrite is given by coil winding radius of wire  $r = 4 \cdot 10^{-4}$  m, at metal strain before twisting. The output ripple current is 1.8 %, and after twisted is 1.6 %. For radius coil  $r = 8 \cdot 10^{-4}$  m at metal strain before twisted, the output ripple current is 1.6 %, and after twisting the output ripple current is 1.4 %. For radius  $r = 16 \cdot 10^{-4}$  m at metal strain before twisted, we obtain the ripples are 1.4%, and after twisting became 1.2 %.

The total impedance consists of air gap, geometry of materials, permeability, and twisted, could be reduce the ripple current about 0.036%.

The prototype could be applied to any system, it was done and tested.

## 7. References

- [1] D.C. Hamil, "Lumped Equivalent Circuit of Magnetic Component, the Gyrator - Capacitor Approach," IEEE Transaction On Power Electronics, Vol. 8, No. 2, April 1993.
- [2] H. Aminah, "Perancangan konverter Cuk konverter Slobodan Akumulasi Energi Dengan Metoda Pendekatan Rangkaian Magnet Gyrator - Kapasitor untuk meminimisasi riak arus keluaran". Thesis, ITB, Feb 1996.
- [3] Herawati Ys, E. Tjipto, I. Garniwa, "Performance Electromagnetic air gap in E Core type make High frequency and low ripple," International Symposium on Antenna and Propagation, November 2006.
- [4] C.-S. Chang, M.-P.Houng, D.-B. Lin, K.-C. Hung, I.-T. Tang, " Simultaneous Switching noise mitigation capability with low parasitic effect using a periodic high-impedance surface structure," Progress in

Electromagnetic Research Letters, PIER Vol. 4, 149-158, 2008

[5] R.E. Collin, "Field Theory of Guided waves." McGraw-Hill Company New York 1960.

[6] S. Hayono, Y. Nakajima, H. Saotome and Y. Saito, "A New Type High frequency Transformer," IEEE Transaction On Magnetic, Vol. 27, No.6, November 1991.

IJERT