

A Remote Home Security System Based on Wireless Sensor Network and GSM Technology

N. Muthu Prabhu¹, S. Sai Mithun²

^{1,2} Electronics And Communication Engineering Department

*Sasurie Academy Of Engineering

Kariyam Palayam, Coimbatore-641 653

Abstract—In this paper, a low-power consumption remote home security alarm system developed by applying WSN and GSM technology is presented. It can detect the theft, leaking of raw gas and fire, and send alarm message remotely. The hardware of this system includes the single chip C5081F310, wireless receiving and sending chip CC1100 as well as the SIMENS TC35 GSM module. The system software developed in C51 language has the ability of collecting, wireless receiving and sending data, and can send a piece of alarm short message to the user's mobile phone when some dangerous condition has been detected.

Keywords-wireless sensor network; global system for mobile communications; home security system;

I. INTRODUCTION

Safety is the most important requirement of home for people. With the development of IT technology, network and automatic control technology, a remote home security monitoring and alarming system becomes more and more practicable today. By combining wireless sensor network (WSN) and GSM technology, this paper designs a low-power consumption remote home security monitoring and alarming system that can detect the theft, leaking of raw gas and fire, and send alarm message to the house owner's mobile phone.

Wireless sensor network is composed of a large amount of miniature self-organizing wireless sensor nodes. By combining three kinds of technology such as sensor, micro-mechatronics and wireless communication, WSN can detect, collect and deal with the object information in its covering area, and send data to the observer. In a word, WSN technology has the advantages of wide covering area, able to remote monitoring, high monitoring precision, fast network establishment and reasonable cost [1]. GSM network has the advantages of mature technology, wide covering area, long communication distance, and sound communication effect and so on. The remote home security system presented in this paper combines so many advantages of WSN and GSM. Firstly, wherever the users are, once some dangerous instance happens in home, such as gas leaking or thief intruding, this system can send alarm short message to the users through GSM network immediately, informing people the possible dangerous circumstances in home. Secondly, the wireless sensor network established in home has the features of ease establishment, without use of cable, and low-power consumption.

II. SYSTEM STRUCTURE AND WORKING PRINCIPLE

The system structure is illustrated in Fig.1. It is composed of the MCU-based home wireless control center, one WSN center node module, and several data collecting nodes, GSM module, GSM network and mobile phone. The WSN data collecting node modules are connected with pyroelectric infrared detector, temperature sensor, smoke detector and gas sensor separately. When the pyroelectric infrared detector finds that some people intrudes into the house abnormally; or when the temperature sensor detects too high indoor temperature and at the same time, the smoke sensor detects overproof smoke concentration; or when the gas sensor detects overproof combustible gas concentration, the sensors will send encoded alarm signal to the home control center through the wireless sensor network established in home. Once the wireless control center receives alarm signal, it will send alarm short message to the users through the GSM module and GSM network immediately.

III. SELECTION AND DESIGN OF SYSTEM HARDWARE

A. Wireless Sensor Network Node Modlue

The wireless sensor network in home of this system is composed of one center node module and several data collecting node modules, operating in point-to-multipoint communication mode. In different application, the formation of a WSN node is not always the same. In general, a WSN node includes four parts: data collecting unit, data processing unit, wireless communication unit and power management unit [2], as illustrated in Fig. 2.

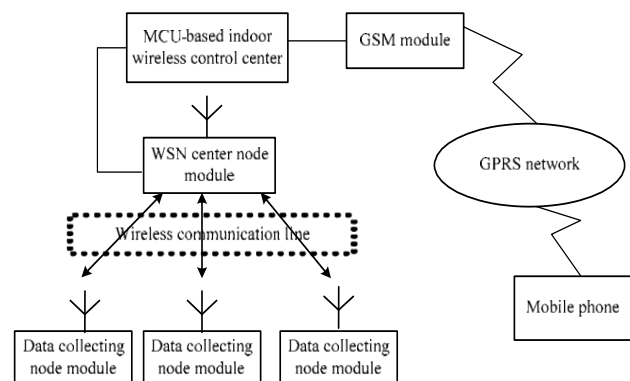

Figure 1. System structural diagram

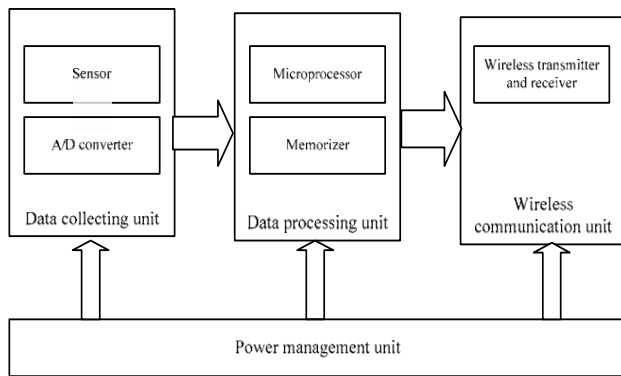

Figure 2. Composing block diagram of WSN node

The data collecting unit is composed of the sensors and A/D conversion module. In this remote wireless home security system, some pyroelectric infrared detectors, temperature sensors, smoke detectors and gas sensors are used.

The data processing unit is responsible to save and deal with the data collected by the sensors and received from other nodes. In this system, the C8051F310 MCU from Cygnal Corporation is chosen as the data processing unit.

The wireless communication unit is often composed of the low power consumption, short distance radio frequency (RF) transceiver. In this system, the wireless dual-way chip CC1100 dedicated in wireless and low power consumption application is chosen to implement wireless communication. C8051F310 MCU can control the main working parameter of CC1100 and communicate with CC1100 through SPI interface. The SPI standard interface include main output slave input (MOSI), main input slave output (MISO) and serial clock (CLK). The master CLK is synchronized with the slave CLK. CC1100 can set the working mode, read and write cache data and status register through SPI bus. The RF chip is connected with MCU through SPI interface to make a wireless communication system that can control receiving and sending function freely. The hardware connection between C8051F310 with CC1100 is showed in Fig. 3 [3]. The SPI interface of CC1100 is to be connected to the hardware SPI interface of CPU. In general, GDO0 or GDO2 pin of CC1100 can be connected to any pin of CPU. But if an interrupt service program is to be used to implement the function of data receiving and transmitting or wireless wakeup, GDO0 or GDO2 pin of CC1100 must be connected to the out interrupt pin of CPU.

Use CR2032 button cell to provide power for the WSN node. It can provide approximately 200mAh power when the voltage is higher than 2.8v.

The data collecting nodes of this system are composed of these four units described before. The center node is a little different, in that it is not connected with sensors but with the GSM module through the indoor wireless control center.

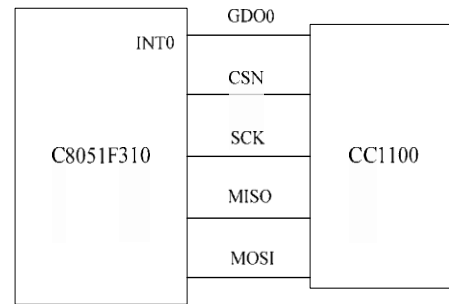

Figure 3. The hardware connection between C8051F310 with CC1100

B. Chosen of GSM Modlue

As the third generation GSM dual frequency module, TC35 GSM module has the following features: compact and low power consumption; support dual frequency of GSM900 and GSM1800; provide standard AT command interface to users; provide fast, reliable and safe transmission of data, voice, short message and fax [4]. It is ideal for this system because of its high quality short message function.

IV. DESIGN OF SYSTEM SOFTWARE

The system software, which is developed with C51 programming language, has two main modules, one for the WSN node communication, and one for the GSM communication.

A. Software Module for WSN Node Communication

In the indoor wireless sensor network, the communication protocol is divided into three layers.

The first layer is physical layer whose function has been implemented by CC1100 hardware itself. The second layer is network layer.

The second layer is network layer which applies TEEN (threshold sensitive energy efficient sensor network) protocol. The data will be transmitted through the wireless sensor network only when the observed value changes suddenly.

The third layer is application layer. In this layer, the system's application software is divided into two modules, WSN data collecting node software module and WSN center node software module. The former, running on the slave MCU of data collecting nodes, is responsible for collecting sensor data and wireless transmitting them. The latter, running on the master MCU of WSN center node, is responsible for wireless receiving data and judging whether it's need to start the alarming process or not. If yes, it will drive TC35 GSM module to send alarm short message to user's mobile phone. The software flow of center node module is illustrated in Fig. 4. And the software flow of data collecting node module is illustrated

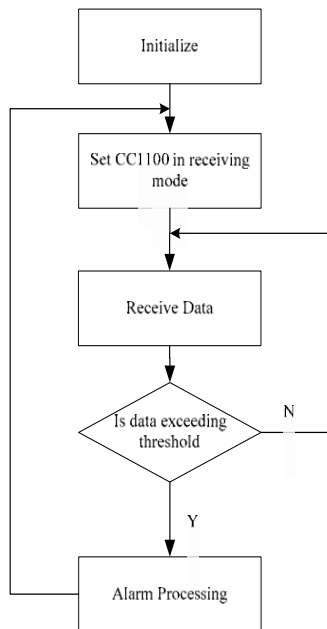

Figure 4. Software flow of center node module

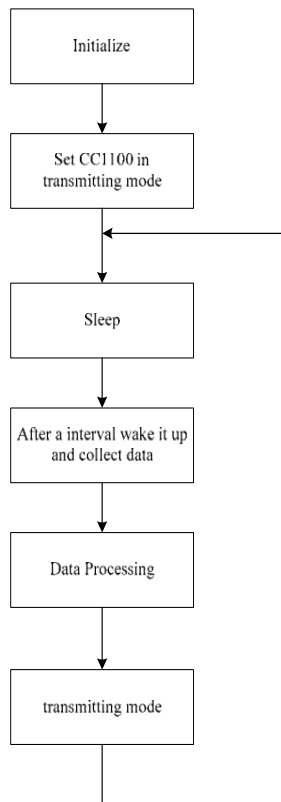

Figure 5. Software flow of data collecting node module

B. Software Module for GSM Communication

When the WSN center node module receives abnormal data, it will drive TC35 GSM module to send alarm short message through GSM network. TC35 GSM module supports standard AT command set. MCU control the operation of TC35 module by inputting different AT function commands through the

serial port [5]. Some GSM AT commands relevant to short message are listed in table 1 [6]. The sending mode of short message depends on the interface supported by the short message service center in the GSM network. European Telecommunications Standards Institute (ETSI) has defined three kinds of interface protocol for sending short message: Block mode, Text mode and PDU mode. Block mode requires the mobile phone manufacture to provide driving support. Text mode doesn't support Chinese text [7]. So at present, PDU mode has become the core of most mobile phone for their short message communication. It can provide more powerful functions than the other modes. So, this system applies PDU mode to send alarming short message.

V. SET UP A PROTOTYPE SYSTEM AND TEST

According to Fig.1, we set up a sample prototype system in our lab room. As mentioned above, choose C8051F310 MCU as the data processing unit of WSN center node module and data collecting node module. Here, C8051F310 has a temperature sensor imbedded that can detect the in-room temperature. After hardware connection, install the appropriate software developed with C51 on MCU-based indoor wireless control center. Then, we can start the test with this prototype system by changing the preset temperature threshold. When the actual in-room temperature exceeds this preset temperature threshold, the control center will immediately trigger TC35 GSM module to send an alarm short message to our mobile phone. Through the test process, this prototype system operated successfully and effectively with reliable and well communication.

VI. CONCLUSION

This paper presents one solution for establishing a low-power consumption remote home security alarm system. The system, based on WSN and GSM technology, can detect the theft, leaking of raw gas and fire, and send alarm message remotely. The hardware of this system includes the single chip C5081F310, wireless receiving and sending chip CC1100 as well as the SIMENS TC35 GSM module. The system software developed in C51 language has the ability of collecting, wireless receiving and transmitting data, and can send a piece of alarm short message to the user's mobile phone when some dangerous condition has been detected. With the advantages of reliability, easy usage, complement wireless, and low power consumption, the system also has practical value in other fields.

TABLE I. SOME AT COMMANDS RELEVANT TO SHORT MESSAGE

AT Command	Command Function
AT+CSMS	Select short message service
AT+CMGF	Set short message encoding mode (1 for text mode, 0 for PDU mode)
AT+CMGS	Send short message
AT+ CSCA	Short message service center number

REFERENCES

- [1] Wu Chengdong, Zheng Jungang, Liu Daren, Xie Kun, "Study on Smart Home Network Technology Based on Wireless Sensor Network", Academic Journal of Shenyang Jianzhu University, Vol. 21, No. 6, pp.753-756, Nov. 2005 (in Chinese)
- [2] Ren Fengyuan, Huang Haining, Lin Chuang, "Wireless sensor network", Journal of Software, Vol. 14, No. 7, pp.1282-1291, March, 2003
- [3] Li Wenzhong, Duan Chaoyu, C8051F Series MCU and Short Distance Wireless Data Communication, Beijing, Beijing University of Aeronautics & Astronautics Press, 2007, pp.188-190
- [4] Qiao Qu, Zhao Guohao, Wei Baohua, "Design of Home Safeguard System Based on GSM Technique", Electronic Engineer, vol.32, No.11, pp.76-78, Nov.2006
- [5] TC35 /TC37 Hardware Interface Description, Version 04. 00. 2002.

IJERT