

A Review: Analysis of SVD based Image Fusion Methods

Indeevar Thakur¹,

¹ M.Tech Student, Department of ECE, Chandigarh Engineering College, Landran, India

Hardeep Saini²

² Assistant Professor, Department of ECE, Chandigarh Engineering College, Landran, India

Abstract - In this paper, we have reviewed different types of Image fusion techniques based on Singular Value Decomposition (SVD) technique. Basically, Image fusion can be described as a technique which is used to generate a single good quality image from one or more images. Image fusion can be applied at many levels viz. pixel level, feature level, signal level and decision level. Image fusion can be applied in many areas like recognition of patterns, to enhance visual features, detection of objects, area surveillance etc.

Key Words: Singular Value Decomposition, Tensors, Image fusion

1. INTRODUCTION

Fusion can be described as the process of combining two or more different entities to form a new entity. Therefore, Image fusion is the process of combining two or more distinct images to form a new single image which will be better and more informative than every other input image. With the progress in technology, we can now obtain information from images of different sources to produce a new high quality image which also contains spatial and spectral information [1]. Thus, Image Fusion can be described as a process that improves the quality of information of a set of images. Image fusion can be used in many fields like medical, microscopic images, remote sensing, robotics etc. There are many objective methods to check the quality of the fused image like peak signal to noise ratio (PSNR), Normalized correlation (NC), Mean square error (MSE), Maximum Difference (MD), Average Difference (AD), Structural Content (SC) and Normalized Absolute Error (NAE) [3].

SVD is a method to identify and order the dimensions along which data points have the most variations. With SVD we can find the best approximation of the original data points with minimum dimensions. It takes a high dimensional, highly variable set of data points and reduces them to a lower dimensional space that can present the substructure of

the original data more accurately. It also orders this data from most variation to the least variation [5]. It is based on a theorem of linear algebra that says that we can break a rectangular matrix A into the product of three matrices

known as an orthogonal matrix (U), a diagonal matrix (S), and the transpose of an orthogonal matrix (V).[3] Thus according to the theorem:

$$A = USV$$

The techniques that are used mostly for image fusion are Intensity-Hue-Saturation (IHS), high pass filtering, principal component analysis (PCA), different arithmetic combinations, multi resolution analysis based methods (pyramid algorithm and wavelet transform), Artificial Neural Networks(ANN), Singular Value Decomposition (SVD) etc.[4]. Nowadays, SVD is becoming very popular technique for image fusion due to many factors like conceptuality, stability and it is also a robust and reliable orthogonal decomposition technique. A huge advantage of SVD is that it can also adjust the variations that are present in the local statistics of an image[2]. In this paper, we have compared and reviewed different types of modifications that can be added to the basic SVD technique.

2. REVIEW ON SVD BASED IMAGE FUSION TECHNIQUES

2.1 Fusion of Multiple Images by Higher-Order SVD of Third-Order Image Tensors:

In this technique, input images are registered, sized, and scaled according to pixel intensities for comparison, and stores information in the form of edges and lines. This method contains a series of calculations. It extracts the input images in such a way so as form a common base, it analyzes the base images to extract details of edges and line, and then fuses these results. The output of this technique is a set of fused images, which contains clear edge-line information [9].

At the start of this technique, the first task is to organize all the input images in such a way so as to form a multiline array which is a third-order tensor, let this be A and then it calculates a higher-order generalization of singular value decomposition (SVD) for A . This higher-order single value decomposition (HOSVD) creates a sub tensor B which contains a set of images which are orthogonal and then these are ordered in decreasing norm which composes a basis for the input. Each of these basis images is a linear fusion of the input images.

The next step is phase analysis of each of these basis images to extract information regarding edges and lines. After that it fuses the raw phase maps according to the pixel-wise square root of the sum of the squares. This calculation must be consistent with the local energy in image phase analysis [10]. Finally, these fused maps are joined to the input images for visualization. They can also be used for other purposes where edge-line information is required. In this method if computations are done for an initial set of images and additional images are acquired then this method is an effective way to update the decomposition, including the basis images. This method is most effective for mixed input images like multimodal images, multispectral images, multi resolution images etc. [7].

2.2 Low Quality Image Information Enhancement Using SVD Fusion Technique:

The basic principle of this technique is to factorize the rectangular real or complex matrix into the diagonal symmetric or Hermitian square matrix using eigen vectors. To divide a system into a set of linearly independent components in which all of the components have their own energy components, this is a stable and effective technique. SVD representation of digital image X with size MxN can be represented as follows:

$$[X]_M = [U]_M [S]_M [V]^T$$

$$U = [u_1, u_2, \dots, u_m]$$

$$V = [v_1, v_2, \dots, v_n]$$

S=[Singular value diagonal matrix]

Here U is a MxM orthogonal matrix, V is a NxN orthogonal matrix, and S is an MxN matrix in which diagonal elements represent singular values. These singular values (SV) describe the luminance of the layer of an image and the corresponding pair of singular vectors (SCs) denote the geometry of that image. Here, U and V are unitary orthogonal matrices and S is a diagonal matrix.

To implement this technique a set of images are taken which have standard resolution. A reference image is chosen from these images. A computer based algorithm is designed to implement the above technique. Block diagram of the algorithm that is to be designed is shown in Figure 1.

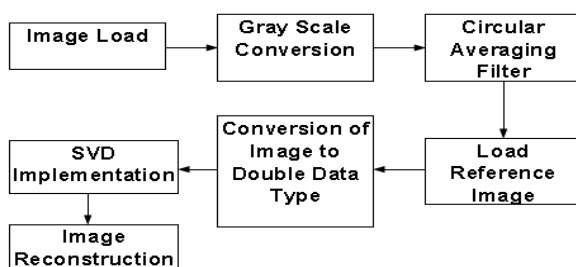

Figure 1: Block diagram representation of computer algorithm

1.3 Multimodal Medical Image Fusion Based On SVD:

This technique considers the source image as tensors. Tensors can be described as the generalization of scalars, vectors, and matrices to any number of indices. This method is more suitable to represent high-dimensional data and to extract relevant information. This technique is based on the following aspects:-

i) As source images are taken from the same scene and are therefore somewhat similar, this technique changes them into a tensor and uses the HOSVD technique to extract their features simultaneously. Also, as image fusion depends upon local information of source images instead of total information, this algorithm selects informative parts of source images to constitute the fused image with the help of divided sub tensors instead of the whole tensor.

ii) A slice of the core tensor yielded from HOSVD of sub tensors reflects the quality of the related image part. This technique uses the sum of absolute values of coefficients (SAVC) as the activity-level measurement of the related part.

iii) To adapt to different activity-level measurements, this uses a flexible sigmoid-function, like coefficient-combining scheme, which includes the usual choose-max scheme and the weighted average scheme and it can also easily fuse multiple or color images.

This technique can be generally divided into three steps. The first step consists of obtaining the decomposition coefficients using transformation. In the second step activity-level measurements are constructed using the above coefficients. And, in the final step these coefficients are merged to construct the fused result in line with the measurements above [9]. Block diagram of this technique is shown in Figure 2.

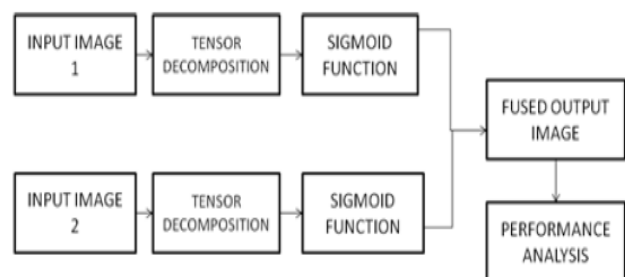

Figure.2 Block diagram of image fusion

2.4 Modified SVD based Image Fusion:

In this method, image fusion is achieved by applying SVD to two different blurred input images. By combining the useful information from these two images, we can produce a more informative and complete image. This can be achieved

by applying SVD to the input images that would make the salient information of each of the image. In this method, image is decomposed into 3 components, U , Σ and V^T which contains required information. Here, U & V^T are orthonormal matrices and Σ represents a diagonal matrix which gives the information about variations of data points. Columns of V are eigen vectors of matrix $A^T A$. Columns of U are like projections of A on the columns of vector V . Σ is a diagonal matrix and its diagonal elements are square root of variation of data points with the columns of V .

With this approach fused image output can be obtained by using the block diagram given in Figure 3 and considering only certain components. In this technique we assigned different singular values which reduced the number of components from each matrix U , Σ , V and also preserving the actual image size. At last image fusion is performed using the reduced number of components and thus we can obtain the fused output [14].

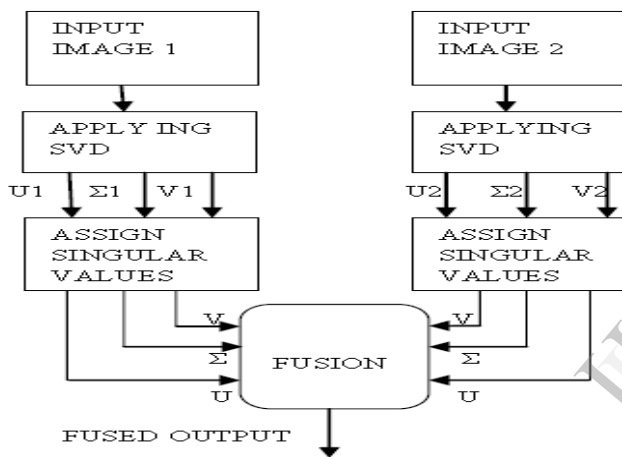

Figure 3. Block diagram of modified SVD based fusion

2. CONCLUSION

The investigations have shown that by using different proposed techniques and algorithms we can bring a lot of improvement in image fusion techniques. Different algorithms showed improvement in different parameters. Thus by selecting appropriate techniques for different purposes we can really improve the quality of output images that are formed after image fusion.

REFERENCES

1. AndrasRovid, Laszlo Szeidl and Peter Varlaki, "The HOSVD Based Domain and the Related ImageProcessing Techniques", Issue 3, Volume 5, 2011, pp 157-164.
2. GagandeepKour, Sharad P. Singh, "Low Quality Image Information Enhancement UsingSVD Fusion Technique", International Journal Of Engineering And Computer Science, Volume 2 Issue 11 November, 2013 Page No. 3227-3231
3. P.AmbikaPriyadharsini, M.R.Mahalakshmi, "Multimodal Medical Image Fusion Based On SVD", IOSR Journal of Computer Engineering (IOSR-JCE) e-ISSN: 2278-0661, p- ISSN: 2278-8727Volume 16, Issue 1, Ver. III (Jan. 2014), PP 27-31.
4. Asha P Kurian, Bijitha S R, Lekshmi Mohan, Megha M Kartha, K P Soman, "Performance Evaluation of Modified SVD based Image Fusion", International Journal of Computer Applications (0975 – 8887) Volume 58– No.12, November 2012.
5. Michael Thomason and Jens Gregor, "Fusion of Multiple Images by Higher-Order SVD of Third-Order Image Tensors," November 28, 2007.
6. A. Khashman, and K. Dimililer, "Image Compression using NeuralNetworks and Haar Wavelet," WSEAS Transactions on Signal Processing, Vol. 4, No. 5, 2008, pp. 330-339.
7. J. Mieikainen, A. Kaarna, and P. Toivanen, "Lossless Hyperspectral Image Compression via Linear Prediction," In S. S. Shen and P. E. Lewis, editors, *Proceedings of Algorithms and Technologies for Multispectral, Hyperspectral, and Ultraspectral Imagery*, VIII, SPIE 4725, pp. 600-608, Orlando, USA, April 1-5, 2002.
8. F. Rizzo, B. Carpentieri, G. Motta, and A. Storer, "Low-complexity Lossless Compression of Hyperspectral Imagery via Linear Prediction," IEEE Signal Processing Letters, 12(2):138-141, February 2005.
9. Ye, Zhengmao and Mohamadian, Habib and Ye, Yongmao, "Practical Approaches on Enhancement and Segmentation of Trimulus Color Image with Information Theory Based Quantitative Measuring," WSEAS Transactions on Signal Processing, Vol. 4, Nr. 1, ISSN 1790-5022 1790-5022, pp. 12–20, 2008.
10. Popa, Camelia and Gordan, Mihaela and Vlaicu, Aurel and Orza, Bogdan and Oltean, Gabriel, "Compressed Domain Implementation of Fuzzy Rule-Based Contrast Enhancement," In Proc. of the 9th WSEAS International Conference on Fuzzy Systems, ISBN 978-960-6766-57-2, pp. 149–155, Sofia, Bulgaria, 2008.
11. RoumenKountchev, Stuart Rubin, MariofannaMilanova, VladimirTodorov, RoumianaKountcheva, "Non-Linear Image RepresentationBased on IDP with NN," WSEAS Transactions on Signal Processing, ISSN: 1790-5052, Issue 9, Volume 5, pp. 315–325, September 2009.
12. V. Barrile, G. Bilotta, "Object-Oriented Analysis Applied to HighResolution Satellite Data," WSEAS Transactions on Signal Processing, Volume 4, Issue 3, Pages: 68-75, 2008.
13. B. Barisic, M. Bonkovic, S. Bovan, "Simple Iterative Algorithm for ImageEnhancement," in Proc. of the 10th WSEAS International Conference on Automation and Information, pp. 157-162, 2009.
14. J. A. Benediktsson, M. Pesaresi, K. Arnason, "Classification and FeatureExtraction for Remote Sensing Images From Urban Areas Based onMorphological Transformations", IEEE Transactions on Geoscience and Remote Sensing, Vol. 41, No. 9., 2003.
15. Moustafa, H.E.-D.; Rehan, S., "Applying Image Fusion Techniques forDetection of Hepatic Lesions," in Proc. of the 6th WSEAS International Conference on Wavelet Analysis & Multirate Systems.