

A Vehicular Wireless Sensor Network for Vehicle Emission Monitoring and Fuel Indication

Mr Vijay Shashanka. R
[Asst.Professor]
Department Of ECE
ASIST,Paritala,A.P

Miss. Neeharika. S
B.Tech,Student
Department Of ECE
ASIST,Paritala,A.P

Miss. Swapna Kumari. K
B. Tech, Student
Department Of ECE
ASIST, Pariala, A. P

Mr. Azees. S D
B.Tech,Student
Department Of ECE
ASIST,Paritala,A.P

Mr. Naga Srinu. G
B.Tech,Student
Department Of ECE
ASIST,Paritala,A.P

Mr. Gopal Rao. P
B.Tech,Student
Department Of ECE
ASIST,Paritala,A.P

Abstract:- Micro-climate monitoring usually requires deploying a large number of measurement tools. By adopting vehicular wireless sensor networks (VSN), we can use fewer tools to achieve fine-grained monitoring. This work proposes VSN architecture to realize micro-climate monitoring based on GSM short messages and availability of GPS on vehicles. We demonstrate our prototype of a GSM-based vehicle network to monitor the concentration of carbon monoxide (CO) gas in areas of interest. The reported data is sent to R.T.A Office. We are calculating the level of fuel in vehicles using petrol level sensors. It is very difficult to calculate the amount of fuel in vehicles so we are using petrol sensors to analyze how much amount of fuel is present in vehicles.

Key Words: VSN, GSM, GPS, Micro Controller, Resistor, Capacitor, CO Sensor, Petrol Sensor.

INTRODUCTION

By adopting vehicles (e.g., taxis and bikes) as carriers with sensing devices and wireless communication interfaces, we can use fewer measurement tools to achieve fine-grained monitoring. We refer to such systems as vehicular wireless sensor networks (VSNs). This paper proposes a VSN to monitor microclimate based on sensors of vehicles. CO gas is a critical index of air quality and global warming. In our prototype, a vehicle is equipped with a CO sensor, a GPS receiver, and a GSM module, which form a GSM based intra-vehicle wireless network. Each of such vehicles thus serves as a vehicular sensor. We are using petrol level sensor for calculating the petrol level in vehicles and we are displaying on LCD.

BLOCK DIAGRAM

In this project we are detecting CO gas released will be measured and given to the ARM 7 LPC 2148. MicroController compares this data with predefined data, if it exceeds the threshold level then GSM is activated. GSM modules will transmit this data to the mobile number which is located in the R.T.A office. Through GPS we are tracking the vehicle and also we are detecting amount of fuel in vehicles. So we are keeping two petrol sensors for calculating the amount of fuel in petrol tank and it is displayed on LCD [16*2].

Buzzer driver is used to drive the buzzer. The electronic buzzer was housed in two cadmium plated steel

compartments joined together to form one unit. If the petrol level in tank is going to complete, then buzzer is activated. A level shifter is usually a part that converts digital signals from one logic standard to another. We are assigning the data to ARM7.

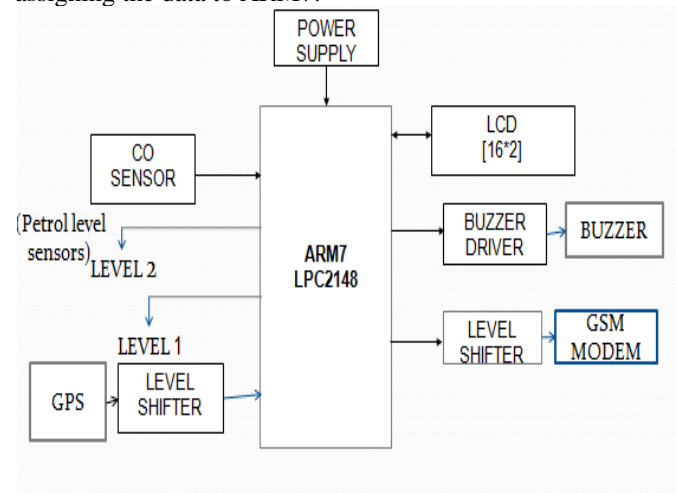

MODULES AND THEIR DESIGN

A. ARM 7 LPC2148

ARM7 is one of the widely used micro-controller family in embedded system application. ARM is a family of instruction set architectures for computer processors based on a reduced instruction set computing (RISC) architecture developed by British company ARM Holdings. A RISC-based computer design approach means ARM processors require significantly fewer transistors than typical processors in average computers. This approach reduces costs, heat and power.

LPC2148 is the widely used IC from ARM-7 family. It is manufactured by Philips and it is pre-loaded with many inbuilt peripherals making it more efficient and a reliable option for the beginners as well as high end application developer. LPC2148 works on 3.3 V power supply. LM 117 can be used for generating 3.3 V supply. However, basic peripherals like LCD, ULN 2003 (Motor Driver IC)

etc. works on 5V. So AC mains supply is converted into 5V using below mentioned circuit and after that LM 117 is used to convert 5V into 3.3V.

Features of LPC214x series controllers.

- 8 to 40 KB of on-chip static RAM and 32 to 512 KB of on-chip flash program memory. 128 bit wide interface/accelerator enables high speed 60 MHz operation.
- In-System/In-Application programming (ISP/IAP) via on-chip boot-loader software. Single flash sector in 400 ms programming of 256 bytes in 1ms.

B. GSM

GSM (Global system for mobile communications) MODEM is a class of wireless MODEM devices that are designed for communication of a computer with the GSM and GPRS network. A GSM modem is a specialized type of modem which accepts a SIM card, and operates over a subscription to a mobile operator, just like a mobile phone. From the mobile operator perspective, a GSM modem looks just like a mobile phone. When a GSM modem is connected to a computer, this allows the computer to use the GSM modem to communicate over the mobile network. While these GSM modems are most frequently used to provide mobile internet connectivity, many of them can also be used for sending and receiving SMS and MMS messages.

It requires a SIM (Subscriber Identity Module) card just like mobile phones to activate GSM MODEM is a class of wireless MODEM devices that are designed for communication of a computer with the GSM network. A GSM MODEM can perform the following operations:

1. Receive, send or delete SMS messages in a SIM.
2. Read, add, search phonebook entries of the SIM
3. Make, receive, or reject a voice call.

The MODEM needs AT commands, for interacting with processor or controller, which are communicated through serial communication. These commands are sent by the controller/processor. The MODEM sends back a result after it receives a command.

A GSM module assembles a GSM modem with standard communication interfaces like RS-232 (Serial Port), USB etc., so that it can be easily interfaced with a computer or a microprocessor / microcontroller based system. The power supply circuit is also built in the module that can be activated by using a suitable adaptor.



C. GPS [Global Positioning System]

The Global Positioning System (GPS) is space-based navigation system that provides location and time information in all weather conditions, anywhere on or near the Earth where there is an unobstructed line of sight to four or more GPS satellites.

Here we are using GPS system to know vehicle position on earth. Specifically Designed for OEM Applications, it has a GPS receiver module with high sensitivity, low power consumption, and 20 channels. Compared with other independent GPS solutions GPS9548 is able to help Users gain and continuously track GPS signals at a very low signal intensity, which means GPS9548 can be used in the environment where it has never been thought to be accessible, such as Buildings of the city building, dense forest, garage, and many indoor environment, with a positioning accuracy of less than 10 meters.

With only an addition of relevant circuit at the periphery, positioning information including time, longitude, latitude, rate, moving direction, etc., can be output through the serial. The GPS module can receive the data by connected to ARM7 development-board URAT0 through RS 2

32 port., or even to monitor high-valued assets in transit.



E. CO Sensor

MQ-7 gas sensor has high sensitivity to Carbon Monoxide. The sensor could be used to detect different gases contains CO, it is with low cost and suitable for different applications.

Character:

- High Sensitivity (MQ7 Sensor)
- Detection Range: 10 - 10,000 ppm CO
- The sensor can operate at temperatures from -10 to 50°C and consumes less than 150 mA at 5 V.
- Good sensitivity to Combustible gas in wide range
- High sensitivity to Natural gas
- Long life and low cost
- Simple drive circuit.

F. Level Shifter

Bi-directional level shifter and translator circuits are used to interface between applications with different supply voltage and input-output voltage levels.

Features

- Wide supply voltage range
- Low propagation delay.
- 3-state output options
- Overvoltage tolerant options.

G. Petrol Level Sensor

A magnetic level gauge is used to measure the level of fluids. A magnetic level gauge includes a “floatable” device that can float both in high and low density fluids. Magnetic level gauges may also be designed to accommodate severe environmental conditions up to 210 bars at 370 °C. Magnetic float level sensors involve the use of a permanent magnet sealed inside a float whose rise and fall causes the opening or closing of a mechanical switch, either through direct contact or in proximity of a reed switch. With mechanically actuated floats, the float is directly connected to a micro switch. For both magnetic and mechanical float level sensors, chemical compatibility, temperature, specific gravity (density), buoyancy, and viscosity affect the selection of the stem and the float.

RESULT AND DISCUSSION

In above discussion the system is used to decrease the pollution by implementing a Vehicular Wireless Sensor Networks (VSN’s) and we are using petrol level sensor to calculate the level of fuel present in vehicles. Now-a- days, pollution is the main problem so in order to decrease it we are using CO sensor in vehicles. If it exceeds threshold level we are sending message to R.T.A office through GSM. Through GPS they will track the vehicle.

It is very difficult to know how much amount of petrol is present in vehicles, so we are designing the circuit with two petrol level sensors to calculate the level of fuel is

D. LCD [Liquid Crystal Display]

LCD stands for Liquid Crystal Display which is used to display numbers, strings and special characters as per the application. It is one of the widely used modules in embedded system. Almost all embedded product requires LCD. Advantage of LCD over LEDs is its ability to display any number, alphabet, special characters and user defined symbol (at extra effort for programming) without increasing number of pins required to be connected with controller. Interfacing of LCD with LPC2148 differs little bit compared to interfacing with 8051 or AVR which operates on 5V. LCD operates on 5V but LPC 2148 operates on 3.3V so we have to take care of this fact for the controller pins which has to be connected with LCD.



present in vehicles. If amount of fuel is less than one litre then buzzer will give beep sound and then also displayed on LCD. In this way at half litre another buzzer is activated and displayed on LCD.

FUTURE SCOPE

In future this project is important to detect the carbon monoxide which is releasing through vehicles. If the persons using their vehicles more than 10 years then it can release more poisonous gases, so in order to decrease it we are using sensors and sending messages to R.T.A office. It is easy process to implement. In some vehicles it was difficult to know the fuel level, so we use petrol level sensors for giving correct value of fuel in vehicles through which they check and they will take certain precautions.

REFERENCES

- [1] Google Maps. [Online]. Available: <http://maps.google.com>.
- [2] C.S Raghavendra, Krishna M. Sivalingam, Taieb Znati, Wireless Sensor Networks.
- [3] Deep Gupta, Brajesh Kr. Singh and Kuldeep Panwar "A Prototyping Model for Fuel Level Detector and Optimizer" page no 226- 229 - African Journal of Basic & Applied Sciences 4 (6): 226-229, 2012 ISSN 2079-2034
- [4] Daniel R. McGlynn, "Vehicle Usage Monitoring And Recording System", US Patent 4072850, February 1978.
- [5] Betta, G., A. Pietrosanto and A. Scaglione," 1996. A digital liquid level transducer based on opticalfiber", IEEE Trans. Instrum. Meas., 45: 551-555.
- [6] C.S Raghavendra, Krishna M. Sivalingam, Taieb Znati, Wireless Sensor Networks.



CONCLUSION

This paper is displaying one of the models of the detection of CO sensor using two modems GSM and GPS. The paper showed the proposed system design, the block diagram, working principle and the simulation results. The main idea of the working principle of the system is detecting the carbon monoxide and sending a signal to microcontroller for activating GSM and GPS modems. Initially GPS modem identify the location of vehicle and then sending message to R.T.A office through SMS by using GSM modems. We are calculating the fuel level and displaying on LCD.