

Application Of D-STATCOM & SCESS In Distributed Transmission Lines For Mitigating The Effects Of Faults

Brahmam Yadav Vakadani¹, Shailaja Ponnamm²

**(PG Student, Department of EEE, Teegala Krishna Reddy Engineering College, JNTU- Hyd, AP, INDIA)*

*** (Assistant Professor, Department of EEE, Teegala Krishna Reddy Engineering college, JNTU-Hyd, AP, INDIA)*

Abstract:

This paper proposes a flexible D-STATCOM (Distribution Static compensator) and its new controller system, that be able to both mitigate all types of faults and operate as a Distributed Generation (DG), when it supplies power to sensitive loads while the main utility source is disconnected (i.e. it is under islanded operating condition). Thus D-STATCOM operates same as a flexible DG (FDG) and consequently, it is called Flexible DSTATCOM (FD-STATCOM). This paper validates the performance of FD-STATCOM system to mitigate power quality problems and improve distribution system performance under all types of system related disturbances and system unbalanced faults, such as Line-to-Line (LL) and Double Line to Ground (DLG) faults and supplies power to sensitive loads under islanding condition. In this paper, the 12-pulse D-STATCOM configuration with IGBT is designed and the graphic based models of the D-STATCOM are developed using the MATLAB. The reliability and robustness of the control schemes in the system response to the voltage disturbances caused by LL and DLG faults and islanded operating condition are obviously proved in the simulation results .components; super capacitor energy storage system (SCESS), FACTS, Tow machine power system, active and reactive powers.

I. INTRODUCTION

DG provides many potential benefits, such as peak shaving, fuel switching, improved power quality and reliability, increased efficiency, and improved environmental performance. There is a high demand for utility DG installations due to their advantages of deferment or upgrading the distribution infrastructure. Most DG units are connected to the distribution system through a shunt nonlinear link such as a VSI or a Current Source Inverter (CSI) [1]. There are many types of DG. Among them are wind, biogas, fuel cells and solar cells. Generally, these sources are connected to grid through inverters and their main function is to deliver active power into the grid. The DGs are designed to supply active power or both active and reactive power. Flexible DG systems would indeed be possible to implement integrated functions

like harmonic mitigation, unbalance mitigation, and zero sequence component suppression schemes, and etc. The new trends in power electronics converters make the implementation of such multiple functions feasible. A DG is islanded when it supplies power to some loads while the main utility source is disconnected. Islanding detection of DGs is considered as one of the most important aspects when interconnecting DGs to the distribution system. With the increasing penetration and reliance of the distribution systems on DGs, the new interface control strategies are being proposed [2]. This paper proposes a flexible D-STATCOM system designed to operate in two different modes. Initially, it can mitigate voltage sags caused by LL and DLG faults. Secondly, it can mitigate voltage sags caused by three-phase open-circuit fault by opening the three phases of a circuit-breaker and disconnecting the main power source (islanding condition).

Reactive power compensation is an important issue in the control of distribution systems. Reactive current increases the distribution system losses, reduces the system power factor, shrink the active power capability and can cause large-amplitude variations in the load-side voltage [3-4]. Various methods have been applied to mitigate voltage sags. The conventional methods use capacitor banks, new parallel feeders, and uninterruptible power supplies (UPS). However, the power quality problems are not completely solved due to uncontrollable reactive power compensation and high costs of new feeders and UPS. The D-STATCOM has emerged as a promising device to provide not only for voltage sag mitigation but also for a host of other power quality solutions such as voltage stabilization, flicker suppression, power factor correction, and harmonic control [5]. D-STATCOM is a shunt device that generates a balanced three-phase voltage or current with ability to control the magnitude and the phase angle [6]. Generally, the D-STATCOM configuration consists of a typical 12-pulse inverter arrangement, a dc energy storage device; a coupling transformer connected in shunt with ac system, and associated control circuits. The configurations that are more sophisticated use multi-pulse and/or multilevel configurations. The VSC converts the dc voltage across the storage device into a set of three-phase ac output voltages. These voltages are in phase and coupled with the ac system of

network through the reactance of the coupling transformer [7]. A control method based on RMS voltage measurement has been presented in [8] and [9] where they have been presented a PWM-based control scheme that requires RMS voltage measurements and no reactive power measurements are required. In addition, in this given method, Clark and Park transformations are not required. However, they have been investigated voltage sag/swell mitigation due to just load variation while no balanced and unbalanced faults Technologies have been investigated. In this paper, a new control method for mitigating the load voltage sags caused by all types of fault is proposed. While in this paper, the proportional gain of the PI controller is fixed at a same value, for all types of faults, by tuning the transformer reactance in a suitable amount. Then the robustness and reliability of the proposed method is more than the mentioned methods. In this method, the dc side topology of the D-STATCOM is modified for mitigating voltage distortions and the effects of system faults on the sensitive loads are investigated and the control of voltage sags are analyzed and simulated

II.FD-STATCOM STRUCTURE

Unlike the Unified Power Flow Controller (UPFC) which consist from two parts, series and shunt, to manage the flow of active power from one part to the other, FDG consist of one part only, because it has a supply of the active power from DG system. The basic electronic block of the FD-STATCOM is the voltage source inverter that converts an input dc voltage into a three-phase output voltage at fundamental frequency.

These voltages are in phase and coupled with the ac system through the reactance of the coupling transformer. Suitable adjustment of the phase and magnitude of the FD-STATCOM output voltages allows effective control of active and reactive power exchanges between the FD-STATCOM and the ac system.

Fig. 1 shows a typical 12-pulse inverter arrangement utilizing two transformers with their primaries connected in series. The first transformer is in Y-Y connection and the second transformer is in Y- Δ connection. Each inverter operates as a 6-pulse inverter, with the Y- Δ inverter being delayed by 30 degrees with respect to the Y-Y inverter. The IGBTs of the proposed 12-pulse FD-STATCOM are connected anti parallel with diodes for commutation purposes and charging of the DC capacitor. This is to give a 30 degrees phase shift between the pulses and to reduce harmonics generated from the FD-STATCOM. The FDSTATCOM is connected in shunt to the system.

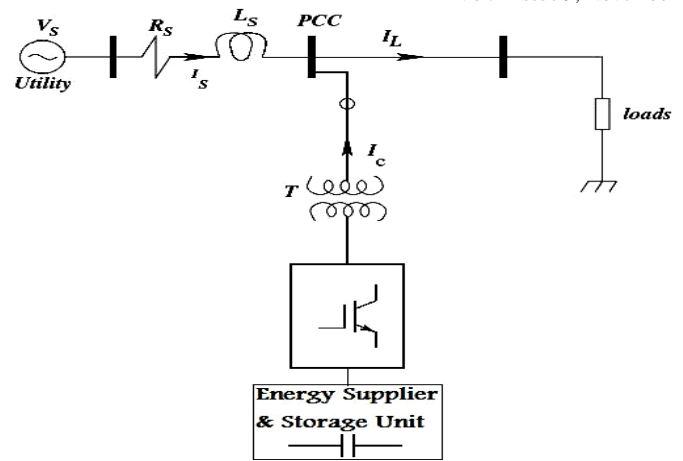

Fig -1 Schematic representation of the FD-STATCOM

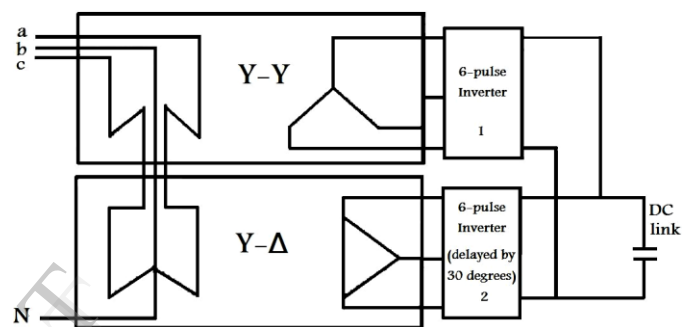

Fig-2 the 12-pulse FD-STATCOM arrangement

III.CONTROL STRATEGY

The block diagram of the control scheme designed for the FD-STATCOM is shown in Fig. 2. It is based only on measurements of the voltage VRMS at the load point.

The voltage error signal is obtained by comparing the measured VRMS voltage with a reference voltage, V_{RMS_Ref} . A PI controller processes the difference between these two signals in order to obtain the phase angle δ that is required to drive the error to zero. The angle δ is used in the PWM generator as the phase angle of the sinusoidal control signal. The switching frequency used in the sinusoidal PWM generator is $f_{sw}=1450$ Hz and the modulation index is $Ma \approx 1$. The modulating angle δ is applied to the PWM generators in phase A. The angles of phases B and C are shifted 120 and 240 degrees, respectively.

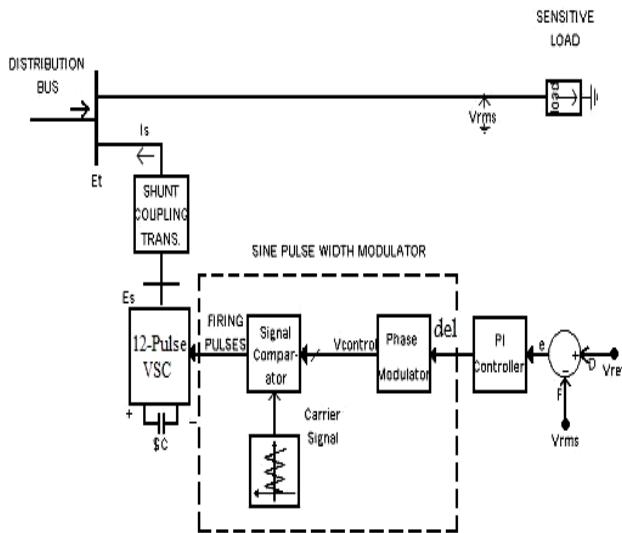

Fig -3 Control scheme designed for the FD-STATCOM

IV. PROPOSED CONTROL METHOD

In this paper, in order to mitigate voltage sags caused by LL and DLG faults and to supply power to sensitive load, a new method is proposed in which the FD-STATCOM and Super Capacitor Energy Storage system (SCCESS) are integrated. Considering this fact that all types of fault may occur in distribution system, controller system must be able to mitigate any types of voltage sags. The integration and control of SCCESS into a FD-STATCOM is developed to mitigate such problems, enhance power quality and improve distribution system reliability. The new method develops the control concepts of charging and discharging the SCCESS by DSTATCOM, and validates the performance of an integrated DSTATCOM/ SCCESS for improving distribution system performance under all types of system related disturbances and system faults, such as LL and DLG faults and under islanded operating condition. The SCCESS is explained as following:

Super capacitor is a new energy device emerged in recent years. It is also known as double-layer capacitor. The electrical double-layer capacitor is a novel energy storage component developed in 1970s. Its pole boards are made of activated carbon, which have huge effective surface so the capacitance could attain several farad even thousands farad. When it is charged, the electric charges are spontaneously distributed negative and positive ion layers on the interface between pole boards and electrolyte, so the super capacitor does not have electrochemical reaction and only have electric charges adsorption and desorption when it is charged and discharged. It has many merits such as high charge/discharge current, less maintenance, long life and some other perfect performance. At the same time, its small leakage current enables it has long time of energy storage and the efficiency could exceed 95%.

The structure of SCCESS is shown in Fig. 3. Its circuit is mainly composed of three parts: rectifier unit, energy storage unit, and inverter unit. Rectifier unit adopts three phase full bridge rectifier to charge super capacitor and supply dc power energy to inverter unit. Inverter unit adopts three phase voltage inverter composed of IGBTs, it connects to power grid via transformer. When SCCESS works normally, voltage at dc side is converted into ac voltage with the same frequency as power grid through IGBT inverter. When only considering fundamental frequency, SCCESS can be equivalent to ac synchronizing voltage source with controllable magnitude and phase.

Energy storage unit i.e. super capacitor energy storage arrays are composed of many monolithic super capacitors. If a large number of super capacitors be in parallel, at the same time improving capacity of power electronics devices in power conversion system can be easily composed of more large capacity SCCESS, but operational reliability and control flexibility will not be affected. Super capacitor is very easily modularized, when required, and it is very convenient in capacity expansion. SCCESS based on DG connected to power grid can be divided into three function blocks: super capacitor arrays components stored energy, power energy conversion system in energy transformation and transmission, and an integrated control system.

SCCESS stores energy in the form of electric field energy using super capacitor arrays. At the lack of energy emergency or when energy needed, the stored energy is released through control system, rapidly and accurately compensating system active and reactive power, so as to achieve the balance of power energy and stability control. Determining the number of energy storage module can save super capacitors, and further reducing volume, quality and cost of the energy storage unit. It is assumed that each super capacitor is represented as an equivalent resistance r_{eq} and equivalent ideal capacitor c_e in series. R and C of super capacitor bank are $R = n_s \cdot r_{eq} / n_p$ and $C = n_p \cdot c_e / n_s$, respectively; that n_s and n_p are the number of monolithic super capacitors connected in series and parallel for constituting storage energy module .

In this paper, SCCESS is made of 10 arrays in parallel with $c_e = 3$ (mF) and $r_{eq} = 1$ (Ω) for every array, as shown in Fig. 3. Fig. 4 shows a typical distribution system controlled by this method. Also, when Timed Fault Logic operates LL and DLG faults are exerted, therefore, the FD-STATCOM supplies reactive power to the system. In this method, the proportional gain is 300. The speed of response and robustness of the control scheme are clearly shown in the simulation results

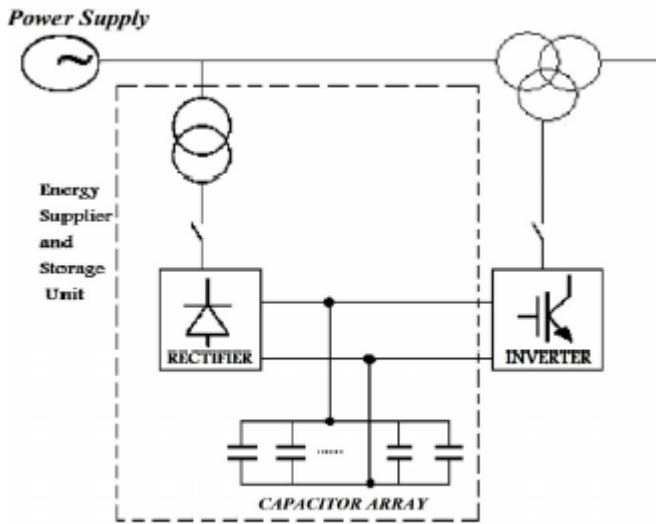

Fig. 4. Structure of SCESS

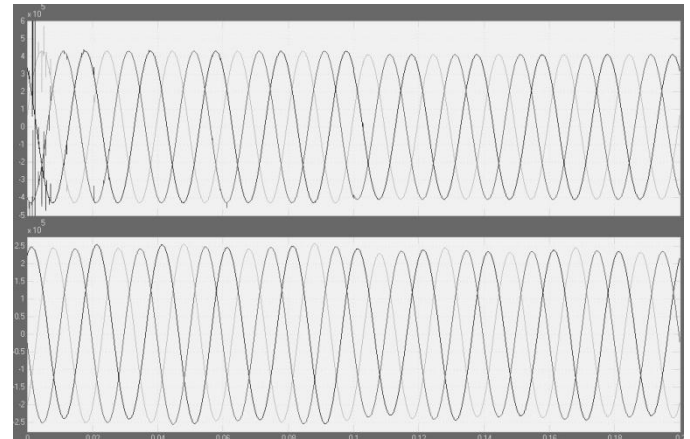

Fig-6 phase voltage and current's of STATCOM

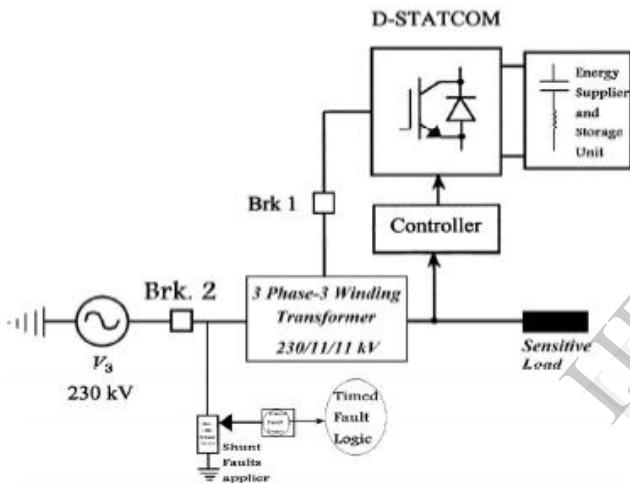

Fig. 5. Distribution system with FD-STATCOM integrated with SCESS and controller

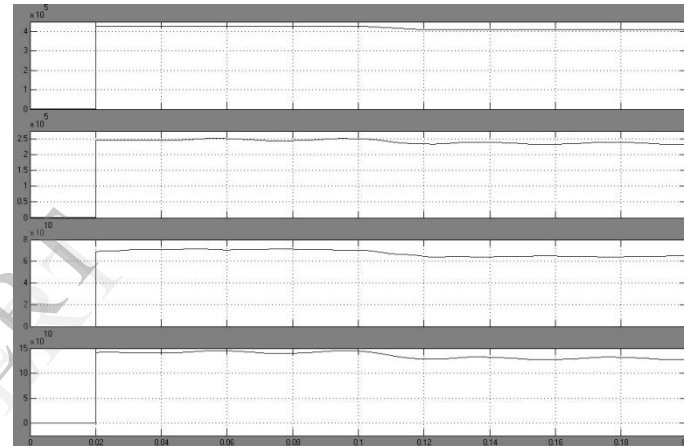

Fig-7 Magnitude of voltage and current

V.SIMULATION RESULTS

Our main aim is to compensate the reactive power with better voltage profile. So the reactive power compensation is done by using fact devices.

Fact device are STATCOM, SSSC, UPFC .in this paper compensation done by two techniques, i.e. STATCOM, SSSC

Coming to the STATCOM, these consist of two transformers one is connected shunt and another one is connected to series. The shunt transformer is connected to rectifier and another transformer (series) to output of the inverter.



Fig-8 magnitude of voltage and current with Statcom

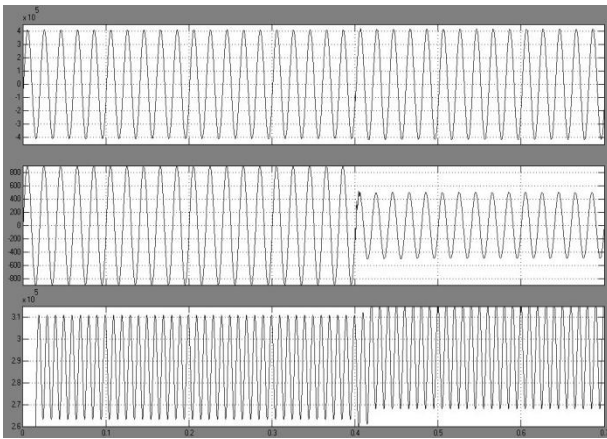

Fig –9 Line Voltage and line current when system is subjected to LG faults

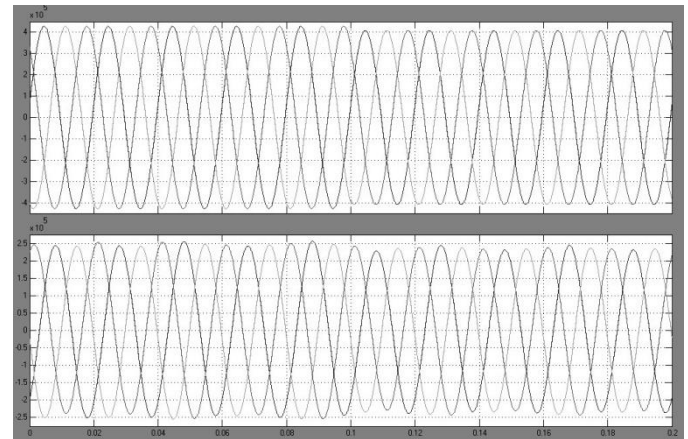

Fig –12 Line voltage and current with Statcom

VI.CONCLUSIONS

Based on obtained simulation results the performance of the SSSC has been examined in a simple two-machine system simply on the selected bus-2, and applications of the SSSC will be extended in future to a complex and multimachine system to investigate the problems related to the various modes of power oscillation in the power systems

In this paper, a flexible D-STATCOM is proposed that could both mitigate unbalanced faults (such as LL and DLG faults) and operate as a DG, when it supplies power to sensitive loads while the main utility source is disconnected. As a result, D-STATCOM operates same as a FDG and consequently, it is called FD-STATCOM. In addition, this paper has proposed a new control method for mitigating the voltage sags, caused by unbalanced faults and islanding condition, at the PCC. The proposed method is based on integrating FD-STATCOM and SCESS. This proposed control scheme was tested under a wide range of operating conditions (under unbalanced faults and islanded operating condition), and it was observed that the proposed method is very robust in every case. In addition, the regulated VRMS voltage showed a reasonably smooth profile. It was observed that the load voltage is very close to the reference value, i.e., 1pu and the

voltage sags are completely minimized. Moreover, the simulation results were shown that the charge/discharge of the capacitor is rapid through this new method (due to using SCESS) and hence the response of the FD-STATCOM is fast.

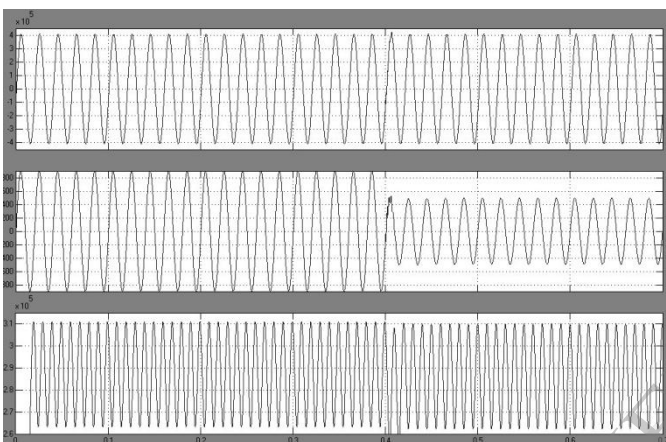

Fig –10 Line Voltage and current when system is subjected to LLLG FAULTS

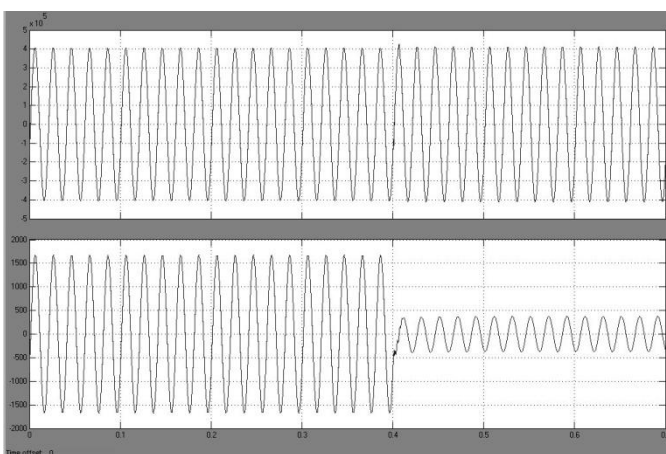

Fig –11 Line voltage and current when system is subjected to LLG FAULT

REFERENCES

- [1] Gyugyi, L. (1989). "Solid-state control of AC power transmission." International Symposium on Electric Energy Conversion in Power System, Capri, Italy, (paper No. T-IP.4).
- [2] Sen, K.K. (1998). "SSSC-static synchronous series compensator: theory, modeling and publications." IEEE Trans. Power Delivery. Vol. 13, No.1, January, PP. 241-246.
- [3] L. Gyugyi, 1994, "Dynamic Compensation of AC Transmission Line by Solid State Synchronous Voltage Sources," IEEE Transactions on Power Delivery, 9(22), pp. 904-911.
- [4] Muhammad Harunur Rashid, "Power Electronics – Circuits, Devices, and Applications," PRENTICE HALL, Englewood Cliffs, New Jersey.07632, 1988.
- [5] Amany E L – Zonkoly, "Optimal sizing of SSSC Controllers to minimize transmission loss and a novel model of SSSC to study transient response," Electric power Systems research 78 (2008) 1856 – 1864.
- [6] B.N.Singh, A.Chandra, K.Al-Haddad and B.Singh, "Performance of sliding-mode and fuzzy controllers for a static synchronous series compensator," IEE Proceedings onhe no. 19990072, IEE, 1999.
- [7] .F. Wang, "Design of SSSC Damping Controller to Improve Power System Oscillation Stability," 0-7803-5546-6/99/\$10.00 © 1999IEEE.
- [8] A. Kazemi, M. Ladjevar DI and M.A.S. Masoum, "Optimal Selection of SSSC Based Damping Controller Parameters for Improving Power System Dynamic Stability Using Genetic Algorithm" Iranian Journal of Science & Technology, Transaction B, Engineering, Vol. 29, No. B1 Printed in the Islamic Republic of Iran, 2005 © Shiraz University.
- [9] I. S. Jacobs and C. P. Bean, "Fine particles, thin films and exchange anisotropy," in Magnetism, vol. III, G. T. Rado and H. Suhl, Eds. New York: Academic, 1963, pp. 271–350.