

Applying Selective Harmonic Elimination in Cascaded Multilevel Inverter using Cuckoo Algorithm

K. M. Ravi Eswar

School of Electrical Engineering
VIT University
Vellore, 632014

Dipen Thomas

School of Electrical Engineering
VIT University
Vellore, 632014

Vasudeva Guptha

School of Electrical Engineering
VIT University
Vellore, 632014

DR . Kowsalya M

Professor
School of Electrical Engineering
VIT University

Abstract—For any application which requires AC electric output, ridding off harmonics from output is of vital importance. In case of multi level inverter among the several methods available to reduce harmonic content in the output, this paper uses selective harmonic elimination by applying metaheuristic optimization cuckoo algorithm. In this paper we worked out the non linear transcendental equation generated by SHE through thorough simulation. The workability and usefulness of the cuckoo algorithm on a seven level multi level inverter was checked. The results attained from the simulation demonstrate that the cuckoo algorithm method has a higher capability to reduce harmonics than both the conventional pulse width modulation and sinusoidal pulse width modulation techniques. Compared to other metaheuristic algorithms cuckoo is much more potent in obtaining the desired harmonic reduction and further more it contains fewer design parameters.

Keywords — Multi level inverter; Selective harmonic elimination; metaheuristic optimization algorithm.

I. INTRODUCTION

A lot of research is currently focusing on developing high quality multilevel inverters [1] for use in industrial applications currently dominated by the standard single level inverter technology. The general accord within the research community is that multilevel inverters will be extensively used in renewable energy applications high voltage transmission and drives [2]. Multilevel inverters provide an alternative to using high power source [3] for application requiring large input voltages. The advantages of MLI include lower harmonic content in the output, lower distortion in input current and the generation of a common node voltage. MLI can design in three conventional topologies: diode clamped, flying capacitor and cascaded. Apart from these stated topologies, various researches have proposed either new hybrid or modified topologies. This paper has used a cascaded H bridge topology which is constituted of several single phase full bridge inverters

cascaded to construct a multilevel inverter. Within this topology the MLI can be further classified into ones using equal DC voltage sources and others with unequal DC voltage sources. For cascaded MLI using equal DC voltage sources such as the one considered in this paper the number of voltage levels in the output is given by $(2S+1)$ where S is the number of single phase full bridge inverters used in the MLI.

The output of MLI is stepped waveform looks approximately like a sinusoidal waveform if the numbers of levels are high. The output waveforms consist of several harmonics and to eliminate these harmonics the switching has to be given properly by using appropriate firing angles. The basis of selective harmonic elimination process lies in a legitimate selection of firing angles. The chosen firing angles should minimize the higher order harmonics [4] below the adequate value. Firing angles can be generated using various methods, but in this paper we employed a metaheuristic algorithm for generating firing angles. SHE is formulated in the form of a non linear equation which will have more than one variable. Using mathematical optimization process the solution of the non linear equation is acquired which is brought in terms of firing angles.

Various algorithms such as Bacterial foraging algorithm simulated annealing algorithm, Particle swarm optimization algorithm etc can be used for this purpose. In this paper we used cuckoo algorithm to generate optimized firing angles which minimizes the THD [5] level of output voltage.

II. CIRCUIT OPERATION

The circuit diagram of seven level multi level inverter is as shown in figure 1 and its output voltage is stepped wave as shown in figure 2.

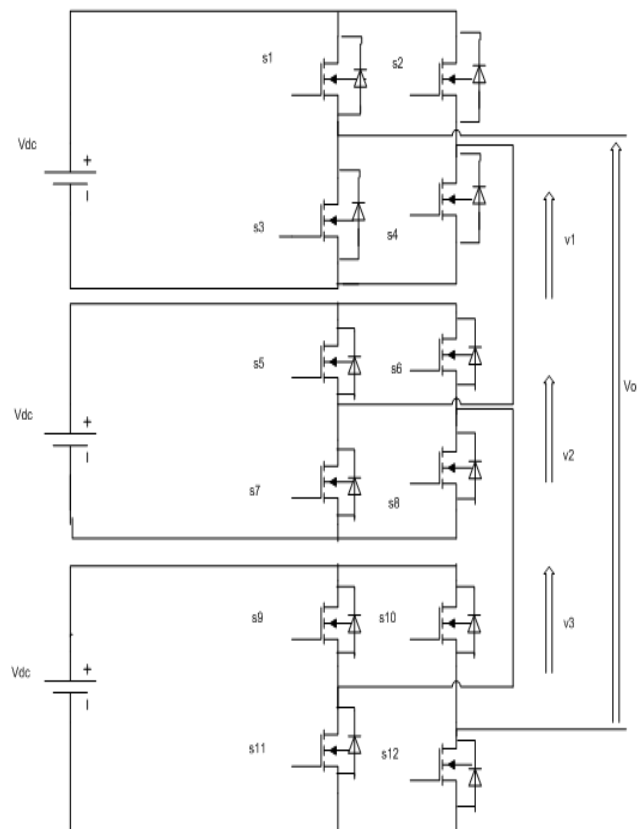

Fig. 1: Single phase Cascaded 7- level inverter

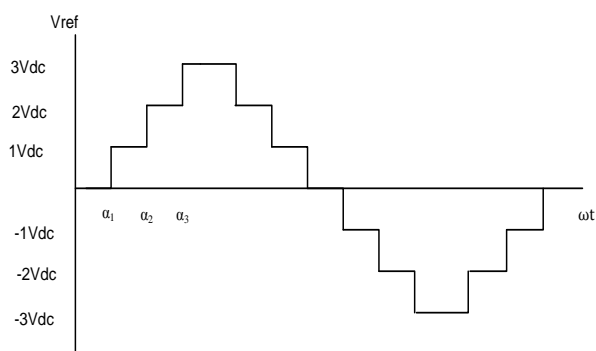

Fig. 2: The full cycle of the phase voltage of 7- level inverter

Seven level MLI consist of 12 switches and switching sequence of these switches are show in table 1

Table 1: Switching sequence

voltages	S 1	S 2	S 3	S 4	S 5	S 6	S 7	S 8	S 9	S1 0	S1 1	S1 2
Vdc	1	0	0	1	0	0	1	1	0	0	1	1
2Vdc	1	0	0	1	1	0	0	1	0	0	1	1
3Vdc	1	0	0	1	1	0	0	1	1	0	0	1
0	0	0	1	1	0	0	1	1	0	0	1	1
-Vdc	0	1	1	0	0	0	1	1	0	0	1	1
-2Vdc	0	1	1	0	0	1	1	0	0	0	1	1
-3Vdc	0	1	1	0	0	1	1	0	0	1	1	0

The Fourier series analysis of the output waveform will yield an expression devoid of even harmonic terms as the output voltage waveform is symmetrical with respect to x axis. Here Fourier series expansion is given by

$$V(\omega t) = \sum_{z=1}^{\infty} V_z \sin(z\omega t) \tag{1}$$

Where V_z is the amplitude of the nth harmonic component. The selection of firing angles α_1, α_2 , and α_3 form the heart of the SHE method. The output equation in terms of firing angles are given by

$$f(z) = \begin{cases} \frac{4}{z\pi} V_{dc} \sum_{k=1}^S \cos(za(k)) & , z = \text{odd} \\ 0 & , z = \text{even} \end{cases} \tag{2}$$

Reduction of harmonic content in output waveform depends on how effectively the lower order harmonics such as the 3rd, 5th, 7th are suppressed. The higher order harmonics can be easily filtered out using suitable filters. In this paper the optimization is done without taking consideration of the 3rd harmonic component, because we assumed that MLI is connected in three phase manner so that the triplen harmonics are eliminated in the lines to line voltages. Therefore we concentrated on the suppression of 5th, 7th and 9th harmonic.

$$\begin{cases} V_1 = \frac{4}{\pi} V_{dc} (\cos(\alpha_1) + \cos(\alpha_2) + \cos(\alpha_3)) \\ V_5 = \frac{4}{5\pi} V_{dc} (\cos(5\alpha_1) + \cos(5\alpha_2) + \cos(5\alpha_3)) \\ V_7 = \frac{4}{7\pi} V_{dc} (\cos(7\alpha_1) + \cos(7\alpha_2) + \cos(7\alpha_3)) \end{cases} \tag{3}$$

The quality of the output waveform is analyzed in terms of the total harmonic distortion factor (THD) and is given by the equation

$$\% \text{ THD} = \left[\left(\frac{1}{a_1^2} \right) \sum_{z=5}^{\infty} a_z^2 \right]^{1/2} * 100 \tag{4}$$

THD is a quantity used to characterize the harmonic content in the output with respect to the fundamental. The equation for THD is a nonlinear transcendental equation. THD factor gives the measure of harmonics present in the output in terms of percentage.

III. METAHEURISTIC ALGORITHM

Metaheuristic [6] algorithms are stochastic algorithms in which there is no concrete assurance of optimization. Loosely speaking these methods work most of the time but not all the time. Metaheuristic algorithm embed a feature of randomization to the local search operation, so as to be suitable for optimization on a global scale with respect to the search space

While searching solution, a metaheuristic algorithm attempts to do so, on the large scale possible. To this above feature it tries to add a component of intensification by which it somehow tries to converge on a locality within the search space containing the selection of best solutions

Metaheuristic algorithms can be either a population based technique [7] such as particle swarm optimization or a trajectory based method and simulated annealing. The cuckoo search algorithm [8] used in this paper is a population based method

IV. CUCKOO SEARCH OPTIMIZATION

Cuckoo search belongs to a class of metaheuristic algorithm whose working is derived from commonly occurring phenomenon in nature. The cuckoo search algorithm mimics the parasitic type of brooding observed in some cuckoo species [9]. It was created by Xin-She Yang and Suash Deb in 2009.

In the algorithm the initial population of cuckoo is set along with a specific number of nests in the work space. Each cuckoo is assigned randomly to the various nest distributed all over the search space. Each cuckoo lays a constant number of eggs in their respective nests. Out of the laid eggs some will be detected by host bird after which either the eggs are destroyed or the nest is abandoned. So each iteration identifies the bad nest and focuses in on the region where there is higher chance for cuckoo eggs to hatch. A probability distribution is formulated to identify the habitat containing the nests favorable for brooding. Starting from next successive iteration the algorithm focuses on optimizing the selected area where the probability of the solutions occurring are higher.

When the algorithm is used three parameters has to be initialized.

1. No. Of nest
2. Step size alpha
3. The probability of cuckoo egg being discovered by the host bird (P_a)

Generation of new solutions is done via levy flights [10] that is for i th- cuckoo with initial solution $x_i(t)$, new solution $x_i(t+1)$

$$x_i^{(t+1)} = x_i^{(t)} + \alpha \oplus \text{Lévy}(\lambda)$$

$$\text{Alpha} = \text{step size} = L/1000$$

Where L is a parameter dependent on the given optimization problem.

The above expression is a stochastic equation for a random walk whose random step length is given by the levy distribution formula

$$\text{Lévy} \sim u = t^{-\lambda}, \quad (1 < \lambda \leq 3)$$

Figure 3 gives the flow chart of cuckoo search algorithm

A. Formulation of fitness function

The fitness function used in this paper is constructed by using the harmonics equations in (3) and the THD equation (4)

$$\frac{(vh5^2 + vh7^2 + vh9^2)^{1/2}}{v1} * 100$$

Constraints: $0 < \alpha_n < 90$ where $n=1, 2, 3$

Subject to constraints: $\alpha_3 > \alpha_2 > \alpha_1$

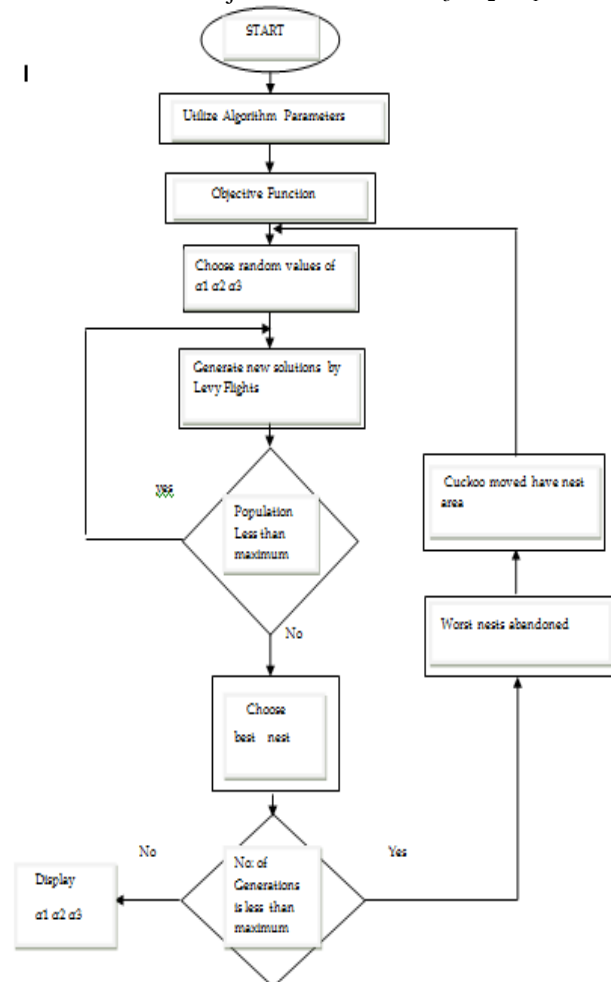

Fig. 3: Flowchart of Cuckoo search

V. RESULTS

In MATLAB -SIMULINK a seven level MLI was designed to test cuckoo search algorithm the algorithm was tested with various values of designs parameters and finely the parameter given in table 2 were reached upon

Table 2: Algorithm Parameters

No. Of nests	25
Step Size	0.01
P_a	0.25

The above values were reached upon after numerous simulations. The firing angles which were obtained by using the algorithm have been tabulated in table 3 along with its THD.

Table 3: Simulation Results

THD Phase (%)	α_1	α_2	α_3
13.12	3.598	24.0912	54.233

Figure 4 gives the THD value obtained upon simulation by using the optimized firing angles determine by the cuckoo search algorithm. To validate the obtained results seven level cascaded inverter was simulated again using sinusoidal pulse width modulation and its THD was measured and the same has been shown in figure 5.

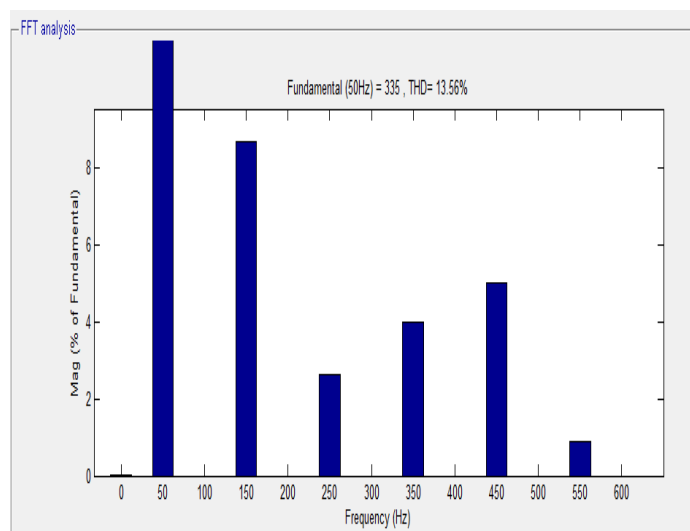

Fig. 4: Obtained THD using Cuckoo optimization algorithm

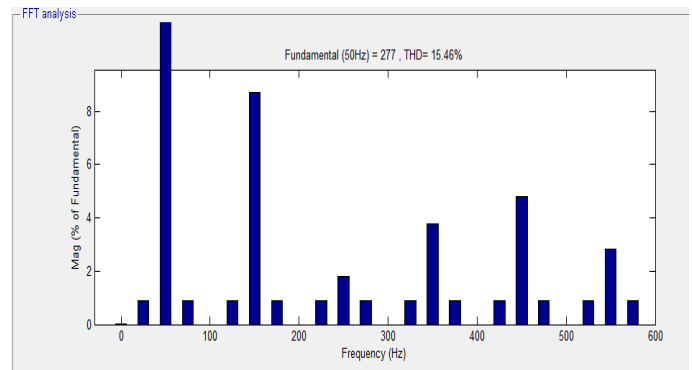

Fig. 5: Obtained THD using Sinusoidal pulse width modulation

VI. CONCLUSION

The 7 level cascaded Multilevel inverter was simulated in Simulink using the firing angles determined by the algorithm and .It was seen that the selective harmonic elimination technique using cuckoo search algorithm gave a lower THD value than sinusoidal pulse width modulation technique. Further after researching previous works which utilized metaheuristic algorithm for harmonic reduction it was observed that the cuckoo search algorithm was more effective than techniques like bacterial foraging, simulated annealing and particle swarm optimization.

REFERENCES

- [1] J. Rodriguez , J.-S. Lai and F. Z. Peng "Multilevel inverters: A survey of topologies, controls, and applications", *IEEE Trans. Ind. Electron.*, vol. 49, no. 4, pp.724 -738 2002
- [2] Rodriguez, J. Bernet, S. Bin Wu Pontt, and J.O. Kouro, S., "Multilevel voltage-source- converter topologies for industrial medium-voltage drives", *IEEE Trans. Ind. Electron.*, vol. 54, pp. 2930- 2945, Dec. 2007
- [3] Q. Song and W. Liu, "Control of a cascade STATCOM with star configuration under unbalanced conditions" *IEEE Trans. Power Electron.*, vol. 24, no. 1, pp. 45-58, Jan. 2009
- [4] C.K. Duey, and R.P. Stratford, "Update of harmonic standard IEEE-519: IEEE recommended practices and requirements for harmonic control in electric power systems" *IEEE Trans. Ind. Appl.*, vol. 25, no. 6, pp. 1025-1034, Nov./Dec. 1989.
- [5] N. Yousefpoor, S. H. Fathi, N. Farokhnia, and H. A. Abyaneh, "THD minimization applied directly on the line-to-line voltage of multilevel inverters" *IEEE Trans. Ind. Electron.*, vol. 59, no. 1, Jan. 2012.
- [6] P. Judea, *Heuristics*, Addison-Wesley, 1984.
- [7] Cerny V."A thermodynamical approach to the travelling salesman problem: an efficient simulation algorithm", *Journal of Optimization Theory and Applications*, 45, 41-51 (1985)
- [8] Jason brownlee. *Clever Algorithms: Nature-Inspired Programming Recipes*. 2011, p 313-332
- [9] Xin-She Yang. *Nature-Inspired Optimization Algorithms*. Luniver Press, 2010, p . 80-93
- [10] Xin-She Yang. *Nature-Inspired Optimization Algorithms*. Luniver Press, 2010, p . 105-115