

# Calibration of Lux Meter using Comparison Method

Aditi Sonar  
(Author)

Dept of Instrumentation Engineering  
Vidyavardhini's College of Engineering & Technology.  
Mumbai, India

Yashodhan Advankar  
(Author)

Dept of Instrumentation Engineering  
Vidyavardhini's College of Engineering & Technology.  
Mumbai, India

Bhavesh Amre  
(Author)

Dept. of Instrumentation Engineering  
Vidyavardhini's College of Engineering & Technology.  
Mumbai, India

Shivaji Babar  
(Author)

Dept of Instrumentation Engineering  
Vidyavardhini's College of Engineering & Technology.  
Mumbai, India

Prof. Trupti Mane Furia  
(Author)

Dept. of Instrumentation Engineering  
Vidyavardhini's College of Engineering & Technology.  
Mumbai, India

**Abstract**—Lux meter is an illuminance measuring instrument used to measure the amount of light falling on a particular surface area at a particular distance from the source of light. Lux meters are used in a wide range of industrial applications as well as in hospitals, museums, photography etc. Lux meter being an electronic instrument undergoes wear and tear during its operation which results in imprecise and erroneous readings in measured lux value. This can incur losses (monetary and material) and give an inferior quality of product. Hence, lux meters need to be calibrated and repaired (if necessary) periodically. In this paper, the comparison calibration method is used where the industrial lux meter (unit under test) is compared against the pre-calibrated lux meter (master) against a light source simultaneously. The importance of calibrating a lux meter is to monitor the intensity of light in an indoor environment ensuring that a correct amount of light falls on the iris of the eye. This project is feasible as compared to the older projects because it is portable, economic and IOT based.

**Keywords**— Calibration, Comparison method, Unit under test, Master lux meter, Photometry, Solid angle, Portable.

## I. INTRODUCTION

Lux meter is a photo-electronic device which is used in the measurement of illuminance in industries like paints and polymer, automobile, pharmacy, building automation as well as it is used on a large scale in photography. It can detect visible light, ultraviolet light as well as infrared rays of light. In other words, it properly gauges the intensity of light that appears to the human eye. It can read the ambient

light and calculate the correct shutter speed and aperture values required to capture an accurate exposure. During normal operation the characteristics of these meters deviate from the design characteristics due to wear and tear in the final product. Lux meter calibration systems are available only at national level. These laboratories have a dedicated setup for lux meter calibration which includes setting up of dark room, optical bench, source lamp of specific lux range, pre-calibrated master lux meters from international laboratories, interfacing software and computerized process to control final product. Hence industries need to calibrate their lux meters periodically. Periodic calibrations need to be performed to detect and correct instrument error as an important element of any quality system.



Fig.1. Lux meter

## II. OBJECTIVE

By using the comparison calibration method, the performance of both the devices (UUT and Master device) and can be checked and used in applications to measure the

illuminance level inside and outside a workplace, so that a required illuminance level can be achieved. The existing calibration systems are available at the National Level laboratories and calibrating a Lux meter from these laboratories is inconvenient to the manufacturing industry spread along the stretch of the country. The new proposed system is pragmatic to the commercial laboratories which can provide calibration facilities at small scale level. The second problem is the size of existing systems. Since these systems are developed by apex laboratories they have dedicated setup and floor space. The third problem is the initial cost involved in manufacturing and setting up the equipment for these huge systems is very high. The new proposed system is compact and economic and can be employed in the existing setup of small scale laboratories. Also the initial cost is much lesser and recurring cost involves periodic calibration of master Lux meter from National Laboratory.

III. EXISTING SYSTEMS

Many apex organizations have developed their own setups for the calibration process of light intensity meters. However, these setups are not feasible to be used at a smaller scale due to large size, difficulty in handling and higher costing.

A. National Physical Laboratory (NPL), Delhi



Fig.2 Luminance Measurement setup at NPL, Delhi.

The National Physical Laboratory of India situated in Delhi is the measurement standards laboratory of India. Fig.2 shows the luminance measurement setup at NPL, Delhi. It maintains standards of SI units in India and calibrates the national standards of weights and measures. It has developed a blackbody setup for luminance intensity and illuminance measurement. The setup consists of a 3.0 m optical bench. The reference scale for luminous intensity is maintained using light quality tungsten filament lamps that are free from

manufacturing defects, stable and their electric and photometric parameters remain constant over time. The reference standard lamps are calibrated periodically from PTB, Germany.

B. National Institute Of Standards & Technology (NIST), USA

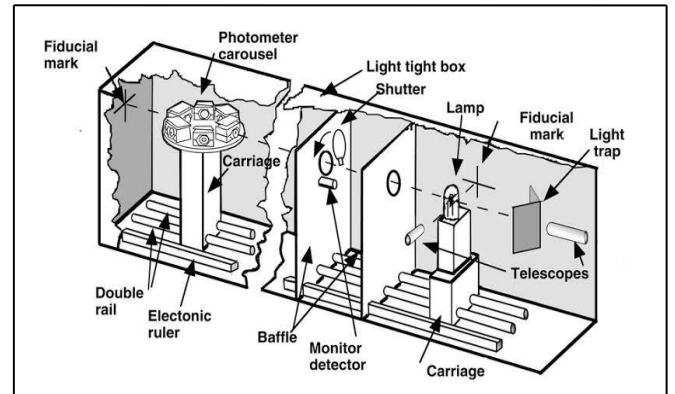

Fig.3. Drawing setup of NIST photometric bench for the measurement of luminous intensity of lamps.

The NIST photometric bench is used for the measurement of luminous intensity of lamps. Fig.3 shows the drawing setup of NIST photometric bench for the measurement of luminous intensity of lamps. The bench allows the easy calibration of customer’s photometers and lamps with respect to the NIST standards. It involves the mounting of six photometers on a carousel and two telescopes to correctly position the lamp along the optical axis. The distance between the lamp and photometer is measured using digital linear encoder. The stability of lamp is monitored using stable monitor detector. The encoder reading is verified by comparison with NIST calibrated vernier caliper.

C. Physikalish-Technische Bundesanstalt (PTB), Germany

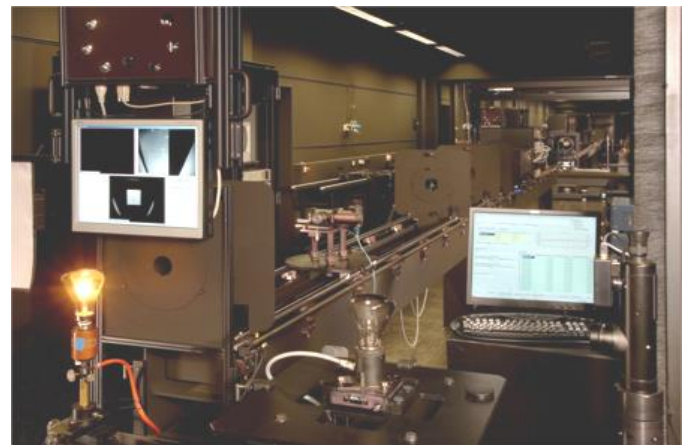

Fig.4. Setup of photometric bench system in PTB, Germany

The PTB in Germany developed a photometric bench system comprising of three photometric benches aligned in a row which can be used all together and can also be used independently. Fig.4 shows the setup of photometer bench system in PTB, Germany. It has a 40 meter long chassis on which reference lamp, movable slits and lux meter are mounted. This system is unique because normally in national institutes, photometric benches of about only 6 meters are in use. At PTB it is possible to vary the illuminance up to about three orders of its magnitude by the usage of new monitoring systems for detecting the stability of luminous intensity as well as camera-aided adjustment. The cost of the setup at PTB is very high and cannot be used in small scale laboratories. Moreover, it is not feasible for the small scale industries to get the calibration done from PTB.

IV. PROPOSED SYSTEM

The proposed system consists of a compact casing placed stationary on a lifting mechanism which is based on a circular crank assembly. The slave lux meter which is to be calibrated against a master lux meter is placed on the radial points of this lifting platform against a constant source of light.

A. Working Principle

Lux is the unit of measurement of brightness, or more accurately illuminance. According to Huygens principle, light from any point source is propagated in forward direction in the form of spherical wavelets. The intensity of the secondary wavelets varies continuously from maximum in the forward direction to a minimum in the backward direction.

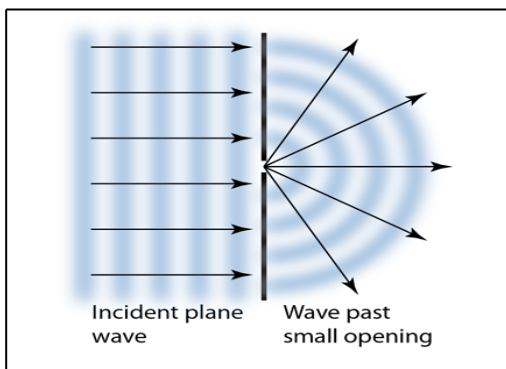

Fig.5. Huygens Principle

Candela is the SI unit of luminous intensity. It is the basic of all measurements of light and all other units are derived from it. Luminous flux ( $\Phi_v$ ) is the time rate of flow of light ( $dQ/dt$ ).

A sphere has a solid angle of  $4\pi$  steradians, thus a source radiating 1 candela in all directions has a total luminous flux of  $4\pi$  lumens. In researches, experiments and calibrations, integrating spheres are used which reflect uniform irradiance and focuses all the available intensity of light at one point where sensors of lux meter are placed. But these integrating spheres require high grade of thermal and mechanical stability. Sources used in this system are of fixed value and require frequent calibration as well as replacement. This induces higher calibration cost for customer.

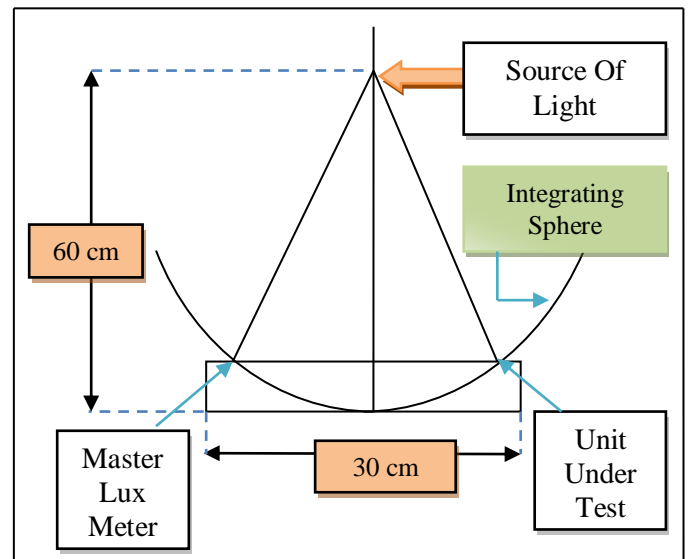

Fig.6. Setup of the proposed system.

An integrating sphere is a spherical hollow cavity that is covered with a reflective coating on the interior side. Light scattered by the interior of this sphere is distributed at equal angles. A photometer is mounted to the inner wall of the sphere to measure the light intensity inside the sphere. In order to measure luminous flux, the spectrometer is connected to the integrating sphere. In this way, we can determine the total amount of energy emitted by the light source in all the directions. Instead, the proposed system is designed in such a way that it clones or replicates a section of the integrating sphere. The source is kept at the centre of an imaginary sphere. Solid angle of imaginary sphere is limited by using non-reflecting Bakelite sheet. The master and UUT are kept on radial surface points of the imaginary sphere. Hence the intensity of light at the master and UUT is constant. The source is maintained at a fixed distance from the ground level. The distance between source and Lux meter plane is varied by using a simple method of crank mechanism for carrying out calibration. An ultrasonic sensor connected to an Arduino is

used to sense the distance travelled by the platform and is displayed on a 16 X 2 LCD display. The assembly is automated in a way such that with every 5 cm elevation in the platform, the motor switches off and the lux value is obtained from the U.U.T. and Master instrument. The lesser the distance covered, the more is the accuracy in the readings obtained.

### B. Block Diagram

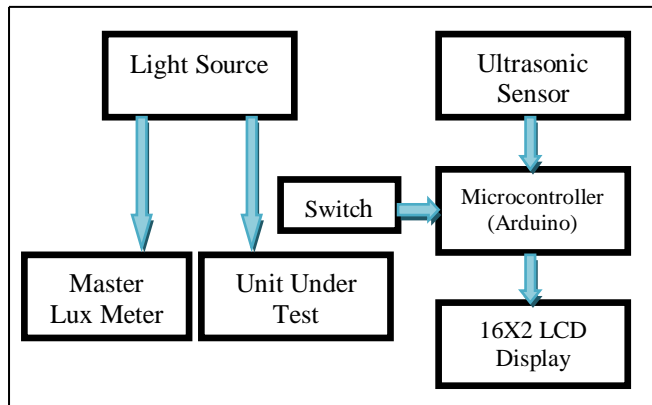

Fig.7. Block Diagram

#### Block Functions

- *Master lux meter* - Master Lux meter or reference Lux meter is the device which acts as a standard for comparison for the unit under test. This lux meter operates within the range of 380 nm to 740 nm. The master Lux meter is calibrated from the apex laboratory whereas the slave lux meter is the device that needs to be calibrated.
- *Light source* - The light source is used to provide identical input to both the master and UUT. The light source is regulated to ensure that it is isolated from line and load fluctuations. The light source used in this project is a round LED light with 50mm diameter for smooth lighting effect that avoids uncomfortable glares.
- *Lifting Mechanism* - A DC motor with a 2 kg torque that rotates at 10 rpm is connected to the crank or an arm to produce motion in a vertical direction. The circular motion of the arm is converted into linear upward and downward motion.
- *Ultrasonic Sensor* - The Ultrasonic sensor HC-SR04 is used here to measure the distance in range of 2cm-400cm non-contact measurement function. The

sensor module consists of ultrasonic transmitter, receiver and the control circuit. The ultrasonic sensor is connected to the Arduino to indicate the elevation height on 16 X 2 inch LCD display in a way that with every 5 cm elevation, the motor should stop and the lux values be recorded.

### C. Circuit Diagram

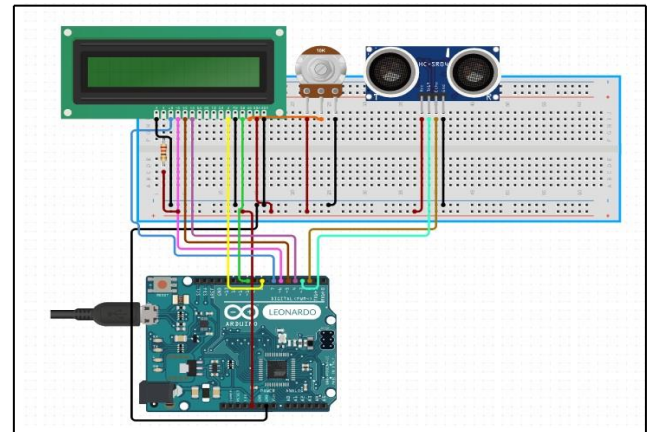

Fig.8. Circuit Diagram

Arduino Uno is a microcontroller board based on the ATmega328P. It has 14 digital input/output pins (of which 6 can be used as PWM outputs), 6 analog inputs, a 16 MHz quartz crystal, a USB connection, a power jack, an ICSP header and a reset button. It contains everything needed to support the microcontroller. Simply can be connected to a computer with a USB cable or power it with AC-to-DC adapter or battery to get started. First of all one must trigger the ultrasonic sensor module to transmit signal by using Arduino and then wait for receiving the echo. Arduino reads the time between triggering and received echo. In circuit connections Ultrasonic sensor module's "trigger" and "echo" pins are directly connected to pin 18(A4) and 19(A5) of Arduino. A 16X2 LCD is connected with Arduino in 4 bit mode. Control pin RS, RW and En are directly connected to Arduino pin 2, GND and 3. And the data pin D4-D7 is connected to 4, 5, 6 and 7 of Arduino.

### V. PROCEDURE

Keeping the light source constant, the distance of platform from ground level is made to vary by rotating the arm of the lifting jack with the help of a motor. The whole system is enclosed in a box made out of Bakelite sheets since it is lighter than wood, cost effective, durable and has a high resistance to heat and electricity. The ultrasonic sensor connected to the microcontroller calculates the distance travelled by the lifting platform. With every 5 cm lift, the motor goes off with a pre-defined delay and the readings on the lux meter show

variations as the intensity of light increases as the sensors move closer to the light source. The values of luxes on both the lux meters are compared manually. For eg, if the master lux meter indicates 250 lux and the UUT indicates 260 lux, then a -10 lux adjustment is made on the UUT so that it indicates a value approximately near to 250 lux. In this way, about 10 readings are taken by lifting the platform.

## VI. RESULTS

Both the lux meters display variations in their readings when the Round LED panel is switched on as they are sensitive to light. Since the master lux meter is calibrated at Apex Laboratories, it shows accurate light intensity values. On every 5 cm elevation in the lifting platform, the performance of both devices are checked, compared and calibrated. For better accuracy, lux values at 1 cm distance should be recorded. To check an overall performance, lux values at 5 cm distance can be measured. The lux value decreases as the sensors move away from the light source. Whereas, the sensor indicates maximum lux value when it is closest to the light source. Table I shows the readings noted for lux intensity values.

TABLE I. LUX VALUES OF SENSORS

Sr .No	Distance (cm)	Master Lux value (lx)	UUT Lux Value (lx) Before calibration	UUT Lux Value (lx) After calibration
1.	5	600	580	600
2.	10	780	773	780
3.	15	830	827	830
4.	20	900	897	900
5.	25	980	970	980
6.	30	1000	998	1000
7.	35	1400	1397	1400
8.	40	1750	1748	1750
9.	45	1830	1830	1830
10.	50	1900	1899	1900
11.	55	2000	1999	2000

## VII. CONCLUSION

The designed system efficiently reduces the cost of calibration as well as it makes the system compact in size. The proposed system is easy to maintain. Also, it is portable and problem associated with frequent source calibration is eliminated due to the implementation of comparison method. The system is reliable and gives repeatability in the readings of Lux value against the length. Future scope includes calibration of lamp (source) and other photometric units associated with it.

## ACKNOWLEDGMENT

We would like to express our deepest sense of gratitude to Dr. Deepak Gawali, Head of the department of Instrumentation Engineering for his support and encouragement in project work. We also express our sincere and whole hearted thanks to our project guide Mrs. Trupti Mane Furia for motivating us to achieve what we set off to accomplish. We are extremely obliged for her guidance received time to time during this project. Furthermore, we would also like to acknowledge with much appreciation to Mr. Pankaj Bhowse (CEO) of Autocal Solutions Private Limited, Vasai (East) for guiding us and sponsoring this project.

## REFERENCES

- [1] Ohno, Yoshihiro. "New method for realizing a luminous flux scale using an integrating sphere with an external source." *Journal of the Illuminating Engineering Society* 24.1 (1995): 106-115.
- [2] J. A. Veitch, "Principles of healthy lighting: highlights of CIE TC 6-11's forthcoming report", *5<sup>th</sup> Int. LRO Light. Res. Symp.*, vol. 2002, no. 1009370, pp. 1-8, 2004.
- [3] Latha, N. Anju, B. Rama Murthy, and K. Bharat Kumar. "Distance sensing with ultrasonic sensor and Arduino." *International Journal of Advance Research, Ideas and Innovations in Technology* 2.5 (2016): 1-5.
- [4] Dias, Maíra Vieira, et al. "Toward proper evaluation of light dose in indoor office environment by frontal lux meter." *Energy Procedia* 122 (2017): 835-840.
- [5] Yang, D. C. H., and Z. S. Sun. "A rotary model for spur gear dynamics." (1985): 529-535.
- [6] Ohno, Yoshihiro, and Georg Sauter. "1993 Intercomparison of Photometric Units Maintained at NIST (USA) and PTB (Germany)." *Journal of research of the National Institute of Standards and Technology* 100.3 (1995): 227.
- [7] Ohno, Yoshihiro. "OSA handbook of applied photometry." *Ecse. Rpi. Edu* (1996).
- [8] Cromer, C. L., et al. "The NIST detector-based luminous intensity scale." *Journal of research of the National Institute of Standards and Technology* 101.2 (1996): 109.
- [9] Zong, Yuqin, et al. *NIST measurement services: Photometric calibrations*. US Department of Commerce, National Institute of Standards and Technology, 2018.
- [10] Eppeldauer, George P., Christopher L. Cromer, and Jonathan E. Hardis. "Luminous intensity measurements of sources using a new detector-based illuminance scale." *Characterization, Propagation, and Simulation of Sources and Backgrounds II*. Vol. 1687. International Society for Optics and Photonics, 1992.