

Cloud Based Street Light Monitoring System

Karthikeyan. M¹, Saravanan. V², Vijayakumar. S³
M.E. Embedded System Technologies¹, Assistant Professor TIFAC Core^{2,3}
Velammal College of Engineering
Chennai, India.

Abstract — The proposed cloud based system involves read and update of data in cloud using internet for an efficient street light monitoring system. It uses ZigBee based wireless devices which enable more efficient street lamp monitoring. It uses a dimming control and Infrared sensor; the information is transferred using ZigBee and is sent to the base station which is used to check the state of street lamps and to take appropriate measures during failures.

Keywords—Cloud computing, Base Station, Lightning systems and Sensors.

I. INTRODUCTION

Energy conservation has become the need of the hour especially in a developing country like India. The fossil fuels are depleting fast and alternate sources of energy have not reached expected levels, even solar energy is costly. Currently, India is the prominent among energy wasting countries for lack of energy efficient planning.

Lighting systems are still designed according to old standards and do not have the latest technological advancements. Due to increasing raw material cost and environmental issues, manufacturers develop new techniques in the aspect of cost and environment.

The first solution and the most intuitive one is the use of new technology light sources. Compact Fluorescent Lamp offers better cost efficient and avoids green house gas emissions providing a better enhancement in electricity and environment.

The second possible is the use of cloud computing based control system that reads and updates data whenever and wherever needed. Base station is created with a web-based stand alone application for controlling and monitoring of the street lights.

Finally the last solution is to use a dimming control ICs and an Infrared sensor for reducing the power effectively. Using these, an enormous amount of power is saved in areas where energy has become a need of the hour.

Our work aims at the unification of the three possibilities, creating an intelligent street lighting system managed by cloud based system which uses CFL light sources and power is conserved.

The management is ensured using a network of sensors that collects the information related to management and maintenance of the system, transferring the information wireless using ZigBee protocol.

In this paper, we present the proposed system, which is able to integrate the latest technologies, in order to describe an advanced intelligent management and control system of street lightning.

II. DEVICES AND METHODS

Fig. 2 shows the block diagram of the proposed system. It consists of a single observation station at the cloud to control the overall street lights in a region. It is a modular system which is expandable easily.

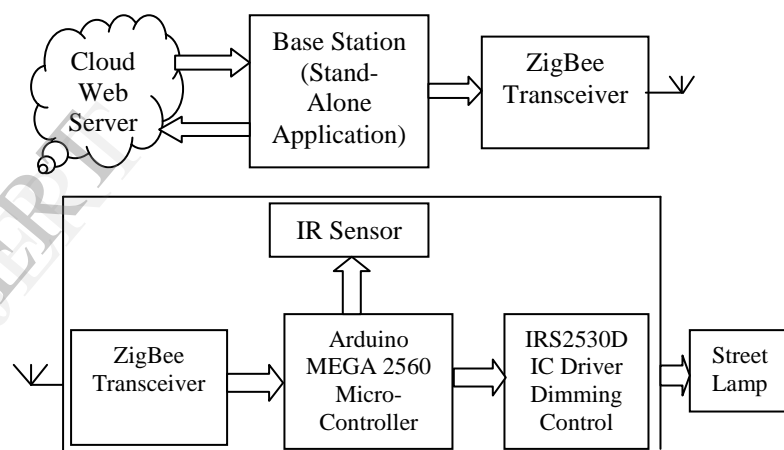

Figure1. Block diagram of the System

The controlling terminal observes the condition of street lights for its perfect working. The sensors are used to control the dim/bright of the street lights based on the intensity of the sunlight. The information about the sensors will be sent using the wireless network to the base station for processing data. During malfunction, the service engineer is informed through graphical user interface and corrective actions are performed.

A. Monitoring Stations

The monitoring station (i.e) the base station located at a particular place for a whole system. It controls the system using cloud update and can also retrieve information whenever needed [1]. The control terminal consists of several modules: the IR sensor, the dimming control circuit.

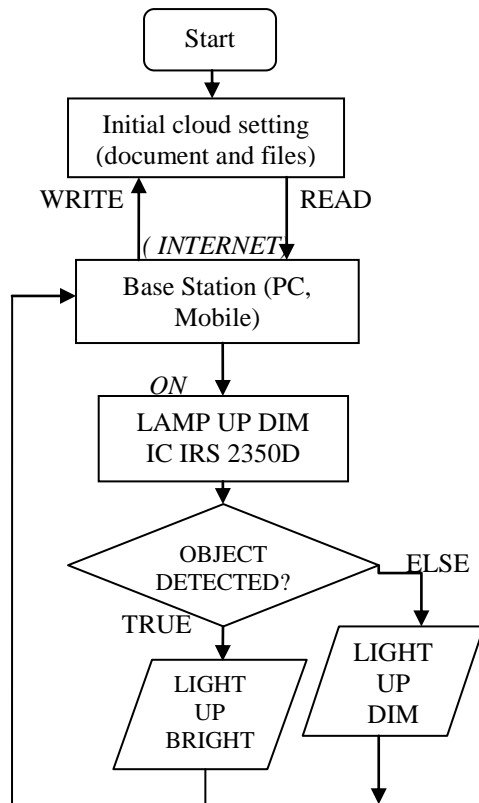

Figure 2. Flowchart of the system

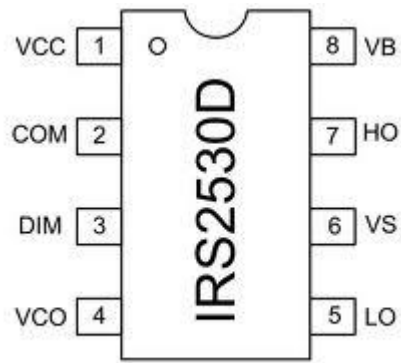

Figure4. Pin diagram of Dimming control circuit

3) Base Control station: The base control station is the hub of the system as it allows the visualization of the entire street light system. The information transmission system consist of ZigBee device that receives status of the lightning system and sends it to the control terminal for the effective actions. The Graphical interface enables us to monitor the status of the lightning system, power consumed by each light in the system.

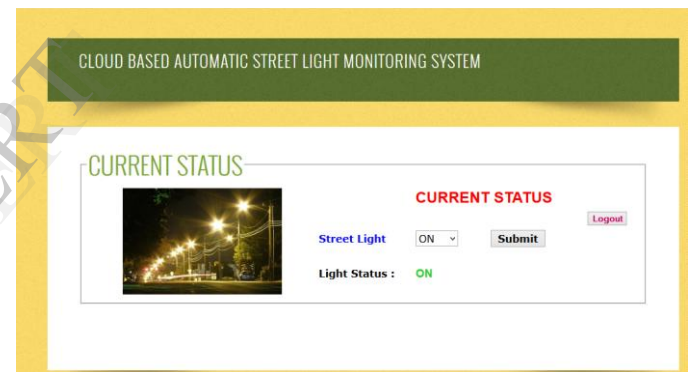
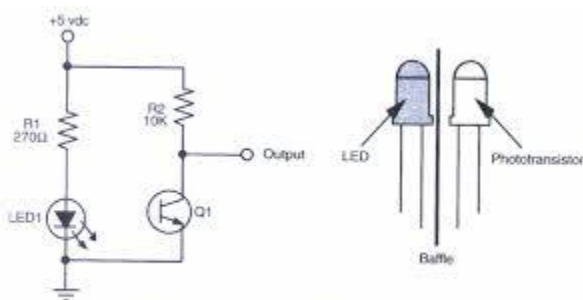

Figure5. Lamp control system GUI.

The above all devices are working together and transfer all the information to microcontroller which processes the data and automatically sets the appropriate course of an action.

1) IR Sensor: The track of the IR sensor is to identify the presence of a vehicle during passage and turning on the street lights bright. The performance of the sensor mainly depended on the environmental conditions[2]. Infrared sensors uses special sensor to modulate IR signal emitted from 2 IR transmitters and detects the modulated IR signal reflected back from the nearby object.



The basic design of the infrared proximity sensor.

Figure 3. IR Sensor

2) Dimming control circuit: The IRS2530D is used as a dimming control IC. This includes an adjustable preheat time, lamp ignition, dimming reference and an automatic restart during lamp exchange. The heat on this IC is a voltage-controlled oscillator with a dimming reference/feedback input. This dimming control circuit is generally used to control the brightness of the street lights; dimming principle states that the dimming of the lamp can control the current flow. This is achieved using a potentiometer with a tank circuit.

B.Cloud computing:

Cloud computing is the technology that uses internet and central remote servers to maintain data and application. Cloud computing allows both consumers and businessmen’s to use applications without installation and access their personal files at any computer with internet access [4]. This technology allows for much more efficient computing by centralized storage of data, process and bandwidth.

Cloud computing is broken down into three segments: “application”, “storage” and “connectivity”. Each serves a different purpose and offers different products for businesses and individuals around the world. Cloud computing is basically a resource that you can utilize online to maintain your business’s platform while you worry about basic assets [5].



Figure 6. Cloud computing access diagram

The three main technology platform strategies are Platform as a Service, Software as a Service, and Infrastructure as a Service. The advantages of cloud are,

1. Cost effective
2. Convenient
3. Speed and Scales
4. Multiple users at one time
5. Flexible
6. Device diversity
7. Lots of storage
8. Customized settings.

C. Arduino MEGA2560

Arduino is an open-source physical computing platform based on a simple i/o board and a development environment that implements the Processing and wiring. Arduino is used to develop stand-alone interactive objects or can be connected to software on your computer.

The Arduino MEGA2560 has 54 digital input/output pins, 16 analog inputs, 4 UARTs, a 16MHz crystal oscillator; a USB connection; a power jack; an ICSP header and a reset. It contains everything to support the microcontroller; simply connecting it to a computer with a USB cable or providing it with AC-to-DC adapter or battery to get started.

The operating voltage of Arduino MEGA2560 is 6V. It can be powered using a USB connection or external power supply. The source is selected automatically. The Mega 2560 differs from all preceding boards is that it is programmed as USB-to-serial converter. It also supports I²C (TWI) and SPI communication. The Arduino includes a serial monitor which allows simple textual data to be sent and receive from boards. It provides a number of facilities for communicating with a computer, or an Arduino or with a microcontroller. The Arduino Mega has a resettable poly fuse that protects computer's USB port shorts and over current.



Figure 7. Arduino Mega2560 Microcontroller.

D. ZigBee Network:

ZigBee is a wireless communication technology based on IEEE802.15.4 standard for communication. ZigBee is the most affordable one in terms of cost, energy consumption, etc [2]. The range of this ZigBee transmission depends on the environmental conditions. The transmission power is mainly depended on the energy efficiency.

In the proposed cloud based system, the network is build to transfer information from each lamp to the control terminal for its management. Though the transmission power is limited, its signal values for each light does not interfere with others.



Figure 8. Tarang ZigBee diagram

In case of failures, the transmitting distance is chosen in a way such that it ensures the signal to reach the base station. The ZigBee communications is implemented using Digi-Max Stream Radio Frequency modules [1]. Normally their transmission range is hundreds of meters in outdoor. Even it has a range of 1.5km but have a higher transmission power which implies high power consumption [1].

The ZigBee receiver consists of high resistance and low probability for receiving corrupted packets [2]. This module consumes 3V from a dc source; the current consumption is in the range of 50mA. The added advantage in this module is that they support sleep mode which consumes less than 10μA of current.

E. CFL Lamp:

A CFL, also called as energy-saving light and compact fluorescent tube, is a fluorescent lamp designed to replace an incandescent lamp. The CFL uses a tube which is curved or folded to fit into space of an incandescent bulb,

and a compact electronic ballast in the base of the lamp [6].



Figure 9. CFL Lamp

CFL uses one-fifth to one-third of the electric power and last upto eight to fifteen times longer than incandescent lamps[6]. It also gives the same amount of visible light as incandescent lamps. Though CFL has a higher price, it offers a reduction of electricity of about five times

F. User Interface:

The application program like on/off condition, power consumption are been developed in Visual Studio environment with the help of ASP.net and C#. Visual Studio is an integrated environment and a frame work used to develop, console application and graphical user interface applications. Visual Studio has many build in languages for applications in it.

C# develops a new concept called parallel programming, which is performed by using the namespace "Threading, Tasks, Parallel, System". Using this namespace it is possible to perform multi core processor programming. Parallel programming is the one which allows the users to develop multi-threaded programming to execute concurrently.



C# is a object oriented programming language, simple, modern, general purpose. C# is designed for Common Language Infrastructure, which consists of executable code and runtime environment that allows various high level languages to be used on different computer platforms and architectures. C# is widely used because it is easy to learn, component oriented, structured language, produces efficient programs.

III. TESTS AND RESULTS.

The prototype was tested in variable real-life conditions to verify the overall functionality and seek better performance.

A. Range Tests

The first tests on the ZigBee modules performance were done at the Electric and Electronic Measurements Laboratory of Roma Tre University, to test the reliability of the communication between two or more ZigBee modules in the following environmental conditions:

1) Open field in line of sight between modules; The tests were carried out using different types of ZigBee modules, Standard and Pro, each one with three different types of antenna(patch, wire, external) provided by the manufacturer.

To check the reliability of the ZigBee transmission, we can use the TMFT2.6 software, provided by the Digi-Max Stream. Test cases were designed to check the network in various real-life operating conditions; clean weather, rain and proximal of electrical or electronic devices possibly interfering with the transmission.

The indoors test were one considering one or more walls between the transmitter and the receiver, while the outdoor ones were performed with one or more natural obstacles.

The TMFT2.6 tool, using a terminal connected to a ZigBee module, sends a packet through the network and verifies that the data are correctly returned back from the ZigBee module which will receive the packet. The results obtained using the minimum transmission power available are very satisfactory; all packets arrive to their destination and are correctly returned, Obtained average reliability of 99.999%

TABLE I Zigbee Reliability Tests

	XBEE Standard			
	Sunny		Rainy	
	50m	100m	50m	100m
No Obstacles	100%	100%	100%	100%
Tree	100%	99.99%	99.99%	99.98%
Hill	100%	99.99%	99.98%	99.96%

B. Power Management

The system was designed to be stand alone, with the control and maintenance is performed from the base station by passing and updating the data in cloud.

Considering the cost differences of the different settings the equation to find the break even is

$$\sum_{i=1}^n kWh_d + \sum_{i=1}^n kWh_b = \sum_{i=1}^n kWh_l \quad (1)$$

Where kWh_d , kWh_b and kWh_l , represent the number of kilowatt per hour used by the specific lamp at dim, bright and at presently operating conditions. n is unknown and represents the activity days necessary to reach the break even between two different choices of lamp posts.

A current transformer is a device used for measurement of electricity. Current transformers are used extensively for measuring current and monitoring the operation of the power grid. Current transformers provides a simple, inexpensive and an accurate means of sensing current flow in power conductors. A current transformer isolates the measuring instruments from what may be very high voltage in the monitoring circuit. Current transformers are used commonly in metering and protective relays in the electrical power industry.

The accuracy of a current transformer is directly related to a number of factors including:

- Burden
- Burden class/ saturation class
- Rating factor
- Load
- External electromagnetic fields
- Temperature and
- Physical configuration.

Current transformers are used to protect, measure and control in high voltage electrical substations and the electrical grid.

IV. CONCLUSION

This paper describes a new intelligent street lighting System, integrates cloud computing technologies to offer high efficiency and considerable savings of power and cost. This can be achieved by using efficient CFL lamps with the control of brightening whenever there is a passage or movement of humans in the area. Intelligent management of the lamp is derived by a control system brightening the lights only whenever necessary, increasing the lamps lifetime too.

Another advantage obtained by control system is that the intelligent management of the street lights by sending data to a base station using ZigBee wireless communication.

The proposed system is particularly suitable for urban and rural areas where the street lights glow continuously bright for the whole night, even when there is no movement of humans. The independent nature of the power-supply network enables implementing the system in remote areas where the classical installations are prohibitively expensive.

The ZigBee is simple and reliable to electronic components, the feature of the sensor network; the processing speed, the reduced cost, and the ease of installation are the features that characterize the proposed system.

The system can be adopted in the future for loads supplied by power supply system, enabling the monitoring of energy consumption. This situation is particularly interesting in the case of economic incentives offered to clients that enable remote control of their loads.

REFERENCES

- [1] Fabio Leccese, "Remote-Control System of High Efficiency and Intelligent Street Lightning Using a ZigBee Network of Devices and Sensors", on IEEE trans. on Power Delivery, Vol. 28, Issue 1, January 2013.
- [2] S.Vijayakumar, S. Karthik Srinivas, "Energy Efficient Street Lightning Control System", IJERT, Vol.1, November 2012.
- [3] Arvind D. Shaligram and Jayashri A. Bangali, "Energy Efficient Street Lightning control System Design for corridor Illumination", Vol. 3 Issue 4, International Journal of Scientific & Engineering Research April 2012.
- [4] Bu-Sung Lee, Chaisiri.S and Niyato.D, "Optimization of Resources Partitioning Cost in Cloud computing", Services Computing IEEE trans. on, Vol. 5, Issue 2, pp164-177, February 2011.
- [5] Iosup.A, Epema.D.H.J, Fahringer. J, Ostermann.S, Prodan.R, Yigitbasi.M.N, "Performance Analysis of Cloud Computing Services for Many-Tasks Computing", IEEE trans. on Parallel and Distributed Systems, Vol. 22, Issue 6, pp931-945, February 2011.
- [6] Andreas Riener, Reinhard Mullner, "Energy efficient pedestrian aware Smart Street Lightning System", International Journal of Pervasive computing and Communications, Vol. 7, Issue 2, pp147-161.