

Comparative Study of Deformation and Other Forces In A Combined Pile Raft Foundation Having Batter Piles to That of Vertical Piles

Reshma Illuri¹, Dr VR Patel²

¹PhD Research Scholar, Department of Civil Engineering, Faculty of Technology & Engineering, The Maharaja Sayajirao University of Baroda, India – 390002;

²Assistant Professor, Department of Civil Engineering, Faculty of Technology & Engineering, The Maharaja Sayajirao University of Baroda, India – 390002;

Abstract— When the horizontal load per pile exceeds what can be withstood by a vertical pile, battered piles are used in conjunction with vertical piles to improve the overall efficiency of the pile–soil system as they transmit the applied lateral loads partly in axial compression, rather than through shear and bending when only vertical piles are used.

A numerical analysis is conducted on a 3D pile raft model with vertical piles and another with inclined piles to check the deformations and other forces for both types of piles.

The analysis includes a soil model of loose sand material. The raft is 1m in depth having piles of 1m in diameter. The model is checked with vertical loading, horizontal loading and inclined loading. Different cases with vertical piles and batter piles were considered. It was observed that raft foundation with vertical piles had more deformation compared to that with batter piles. Future scope of work is to do a parametric study; parameters being pile length, spacing, number of piles, pile diameter, batter angle.

Keywords — batter piles, batter angle, deformation, inclined loading, parametric study, pile raft foundation

1 INTRODUCTION

The increase in construction of tall buildings and skyscrapers has increased massively in the last two decades. There will be more high-rise buildings than ever in the coming decades due to the shortage of land and an increase in human population. Deep foundation, i.e., pile foundation is used for tall buildings. But, until now vertical piles have been the major method. Using batter piles in conjunction with or without vertical piles is a new concept. Tall buildings are subjected to high lateral loads along with axial loads. Only a raft is not sufficient when it is subjected to inclined loading. In this research, a series of analyses (numerical) using Plaxis 3D on a pile raft foundation model in dry sand was carried out to find the behavior of combined pile raft foundation and changes in forces. Analysis was carried out in 13 cases first one being only a raft model subjected to vertical loading and the last case being a raft with batter piles subjected to inclined loading. Deformations and

forces such as shear; axial and bending moments were compared for each case. A comparison between each case was made to check for the most efficient and economical solution. Deformations and forces were found to be less in a combined pile raft with batter piles than in a combined pile raft with vertical piles when subjected to an inclined load.

2 LITERATURE REVIEW

During the last few decades, several researchers have studied the behavior of batter piles using both laboratory tests and theoretical studies. Initially, Matsuo (1938) studied the behavior of batter piles and stated that batter piles were less resistant to lateral loads than to vertical piles. This was contradicted by Evans (1954) who stated that negative batter piles have higher resistance to lateral load compared to that of vertical piles. Murthy (1964) and Prakash and Subramanyam (1965) both independently performed model tests on batter piles in sand under a lateral load and reported that the lateral resistance of a negative batter pile is higher than a positive batter pile.

The bearing capacity of batter piles embedded in sandy soil was found to be higher than vertical piles in an experimental analysis by Mohammed A. Al-Neami (2015).

Difficulties and measures of driving super-long piles in Bohai Gulf have been studied (Yan, Li, and Sun, 2015). It stated that pile refusal was higher in vertical piles than in batter piles. The lateral response of batter piles was analyzed (Lassaad Hazaar, 2017) in which batter piles had better lateral response compared to vertical piles. Hasan (2018) considered pile groups with batter piles to analyze pile-soil interaction. It was observed that there was an effect on the interaction factors with varying parameters like spacing, pile length and diameter.

Batter piles were also analyzed with a combination of lateral and uplift loads (Bajaj & Yadu, 2019). It was observed that the

maximum value of load-carrying capacity is obtained at 80% of combined loading.

However, little work has been reported on numerical studies of batter piles, barring a few theoretical and laboratory test results. In this paper, a 3D FEM analysis using the software Plaxis 3D has been performed to study the behavior of batter piles under inclined loading in comparison to vertical piles under the same loading.

3 MATERIALS AND METHODS

3.1 Materials

3.2 A. Sand

Sand has been used as the soil material and modeled in Plaxis 3D. The properties of soil material are given in Table 1. Drained condition is used for the material with cohesion of 4 kN/m². It is loose and according to the unified soil classification system (USCS), this type of soil is classified as poorly graded sand (SP). The properties of soil and the particle size distribution curve are given in Table 1 and Figure 1 respectively.

B. Pile and Raft

To model the raft, a square metal plate with a width of 5m and a thickness of 1m has been used. To model the piles, bored concrete piles of a diameter of 1m and an elastic modulus of 21 GPa have been used. Raft and pile properties are given in Table 2 and Table 3. Load values are given in Table 4.

Drainage condition		Drained
γ _{unsat}	kN/m ³	15
γ _{sat}	kN/m ³	17
E'	kN/m ³	60000
ν		0.3
C'	kN/m ²	4

Table 2. Properties of raft

Parameter	Unit	Value
Diameter	m	1
Unit weight	kN/m ³	5
Stiffness	kN/m ²	21.00E6

Table 3. Properties of pile

Parameter	Unit	Value
Diameter	m	1
Unit weight	kN/m ³	24
Stiffness	kN/m ²	21.00E6

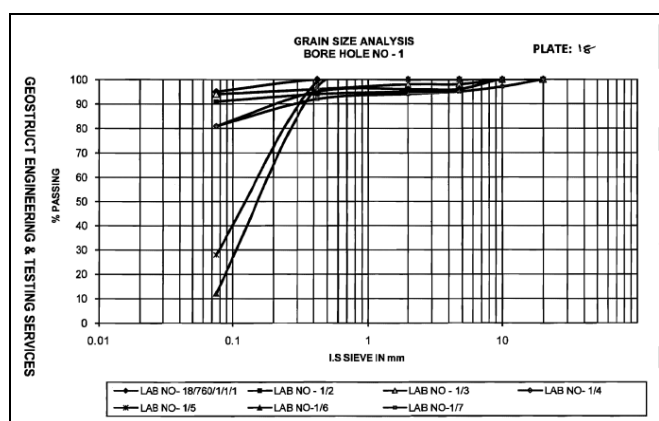

Fig.1 Particle size distribution curve

Table 1. Properties of soil

Parameter	Unit	Value
Material Model		Mohr-Coulomb

Table 4. Load values

Parameter	Unit	Value
Horizontal load value (FX)	kN	2500
Vertical load value (FY)	kN	-1500
Resultant load value (F)	kN	2915

3.3 Methods

The analysis consists of 13 cases, the first being only the raft on a soil model subjected to vertical loading and the last being a combined pile raft foundation having batter piles subjected

to inclined loads. The analysis was performed on Plaxis 3D, which uses Finite element methods for its calculations. Initially, only a raft on loose sand was not sufficient to withstand the inclined loading. Piles were then modeled to withstand the inclined loads and a raft was used as a medium for the uniform distribution of loads from the columns to the piles.

- 1) *Case 1, 2, 3 - Only raft with no piles* – The raft alone with no piles was modeled in a soil model and was subjected initially to vertical loading. Then the same raft model was subjected to inclined loading with a vertical load greater than a horizontal load and vice-versa. The raft model failed when the horizontal load exceeded the vertical load. With this result, further cases were modeled as combined pile rafts having vertical piles and then batter piles (Inclined piles) subjected to both vertical and inclined loading.

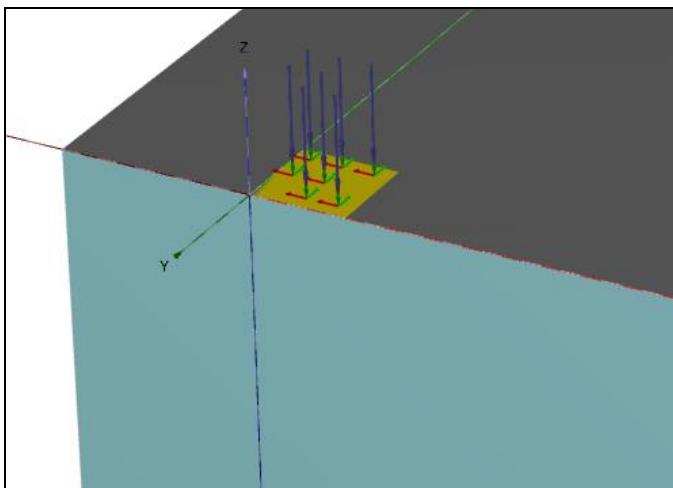

Fig.2 Model of only raft subjected to vertical load

3.3.1 Vertical Pile Analysis

A raft along with two vertical piles at spacing of $3d$ was modeled to check the deformation and forces in the foundation system. The piles were subjected to inclined loading. Piles are fixed at the top. The raft is acting as a single pile cap for both piles. Deformation, stresses and bending moments were obtained for the same.

- 2) *Case 4, 5, 6 - Raft with vertical piles* – As previous cases were not efficient in withstanding the inclined load, the raft was modeled along with 2 piles. Deformation and forces were observed and compared for the cases.

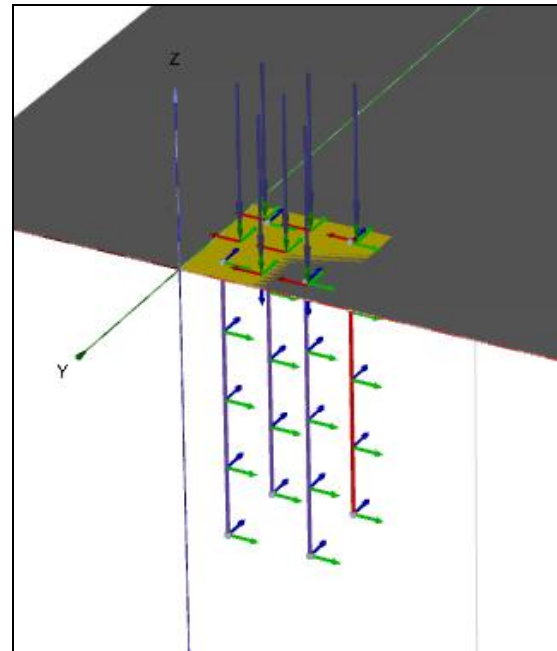

Fig.3 Model of combined pile raft having vertical piles and subjected to vertical load

3.3.2 Batter Pile Analysis

A combined pile raft having batter piles was modeled to check the deformation and other forces on the foundation system. Three different batter angles, 15, 20 and 30 degrees were considered for the piles. The raft was subjected to inclined loading with one case being F_X greater than F_Z and the other case being F_Z greater than F_X .

- 3) *Case 7,8 – Raft with inclined piles having a positive batter angle 15°*

After obtaining the forces for a raft with vertical piles, the foundation system was modeled as a combined raft with inclined piles having a batter angle of 15°. Deformation and forces were observed and compared to the previous cases.

- 4) *Case 9, 10 – Raft with inclined piles having a negative batter angle 15°*

Deformation and forces were observed for a combined pile raft having a negative batter angle as well. These forces were compared to forces obtained on a positive batter angle pile and to a vertical pile.

- 5) *Case 11 – Raft with inclined piles having one positive 15° and one negative 15° batter pile*

Instead of both the piles modeled as negative inclination or positive inclination, the model was considered to have one pile with a positive inclination and another to have a negative inclination.

6) Case 12 – Raft with inclined piles having negative batter angle 30°

Batter angle of pile is increased to 30° and checked for forces.

7) Case 13 - Raft with inclined piles having one positive 30° and one negative 30° batter pile

The model was considered to have two piles each with a positive and a negative inclination of 30° respectively. The deformation and forces were checked to compare batter piles to vertical piles and obtain the optimum or most efficient combination.

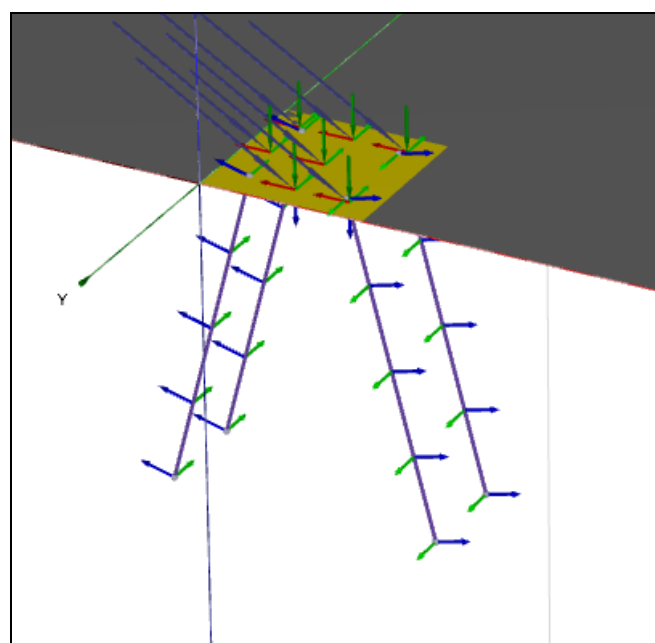

Fig.4 Model of combined pile raft having batter piles and subjected to inclined load

4 RESULTS AND DISCUSSIONS

- Case 1, 2, and 3 - Only raft with no piles – Raft alone is modeled as a plate element on the soil and is subjected to vertical load. The deformation obtained is 9mm. When the same raft is subjected to an inclined load, with a vertical load greater than the horizontal load, deformation increases from 9mm to 16mm, which is a 56.25% increase. Other forces such as axial force, shear and, bending moment show an increase too. When the same raft is again subjected to an inclined load with a horizontal load greater than the vertical load, the model has failed stating that the raft alone is not sufficient to withstand the inclined load (higher horizontal loads).
- Case 4, 5, and 6 - Raft with vertical piles – The total deformation obtained for a raft with vertical piles subjected to vertical loading was 7mm. In the same model

when subjected to incline loading the deformation was much higher to be 18mm.

- Cases 7 to 13 - Then, a raft combined with batter piles having a batter angle 15 degrees was modeled to give a deformation of 8mm. The best case was a raft with batter piles having a batter angle of 30 degrees when subjected to inclined loading (horizontal + vertical loading) as the deformation and forces were lesser compared to previous cases. The deformation was the same as that obtained for a combined pile raft with vertical piles subjected to vertical load only.

Thus, a combined pile raft foundation having batter piles was observed to give lesser deformation than vertical piles. In batter piles, piles with an inclination of 30 degrees were observed to give lesser deformation compared to the other two batter angles. Only a raft in loose sand was not able to withstand the inclined loading. Raft with vertical piles gave deformation larger than foundation having batter piles.

The total deformation obtained for a combined raft with vertical piles subjected to vertical loading was the same as that of the combined raft with batter piles with inclined loading. The shear force and bending moment were also observed to be lesser for batter piles than for vertical piles. The results are tabulated below in Table 5. Each case is compared and tabulated below in Table 6. Graphs of comparison are also provided below.

Table 5. Comparison of a combined pile raft foundation having vertical piles to that of batter piles

Model	Loading	Deformation (mm)	SF (KN)	BM (KN-m)
Raft with vertical piles	Vertical	7	118 (P)	162(P)
			262(R)	140(R)
Raft with vertical piles	Inclined	18	806(P)	1026(P)
			728(R)	482(R)
Raft with inclined piles (15 degree angle)	Inclined	8	245 (P)	290(P)
			352(R)	177(R)
Raft with inclined piles (30 degree angle)	Inclined	7	327 (P)	655(P)
			522(R)	300(R)

(P) – Pile; (R) - Raft

Table 6. Parametric Study

Case Number	Model	Loading
Case 1	Raft	Vertical
Case 2	Raft	Inclined ($F_z > F_x$)
Case 3	Raft	Inclined ($F_x > F_z$)
Case 4	Raft + vertical Piles	Vertical
Case 5	Raft + Vertical Piles	Inclined ($F_z > F_x$)
Case 6	Raft+ Vertical Piles	Inclined ($F_z > F_x$)
Case 7	Raft + Inclined piles (+15°)	Inclined ($F_z > F_x$)
Case 8	Raft + Inclined piles (+15°)	Inclined ($F_x > F_z$)
Case 9	Raft + Inclined piles (-15°)	Inclined ($F_z > F_x$)
Case 10	Raft + Inclined piles (-15°)	Inclined ($F_x > F_z$)
Case 11	Raft + Inclined piles (+15° and -15°)	Inclined ($F_z > F_x$)
Case 12	Raft + Inclined piles (-30°)	Inclined ($F_x > F_z$)
Case 13	Raft + Inclined piles (+30° and -30°)	Inclined ($F_x > F_z$)

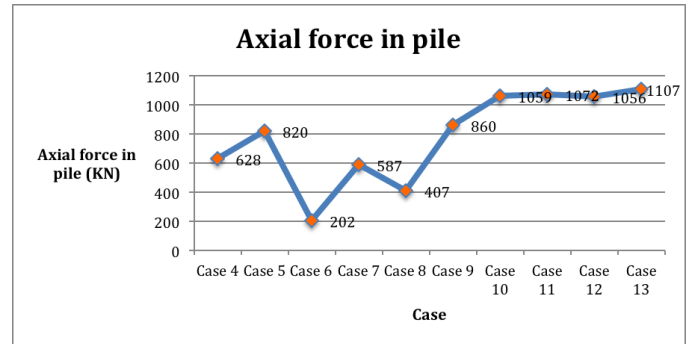

Fig.7 Axial force in pile

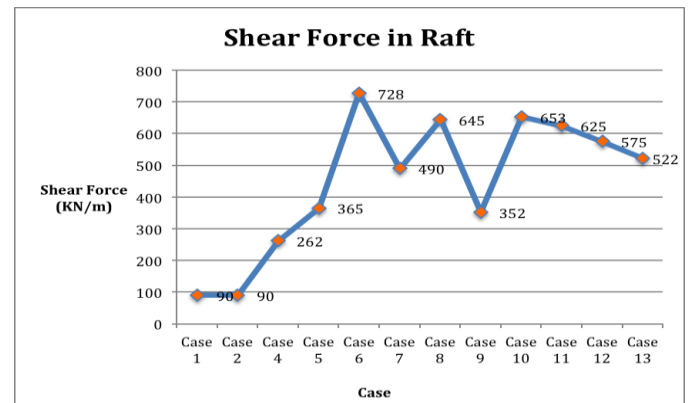

Fig.8 Shear force in raft

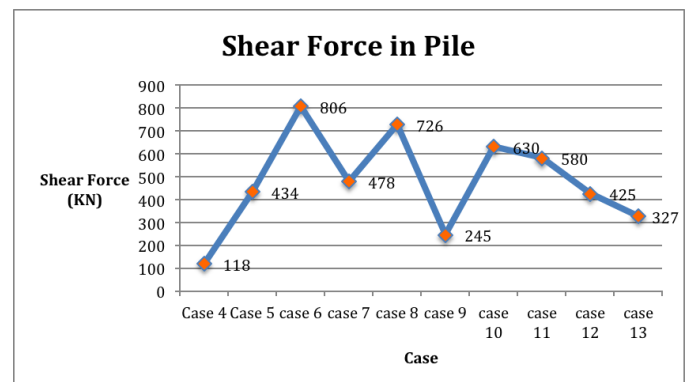

Fig.9 Shear force in Pile

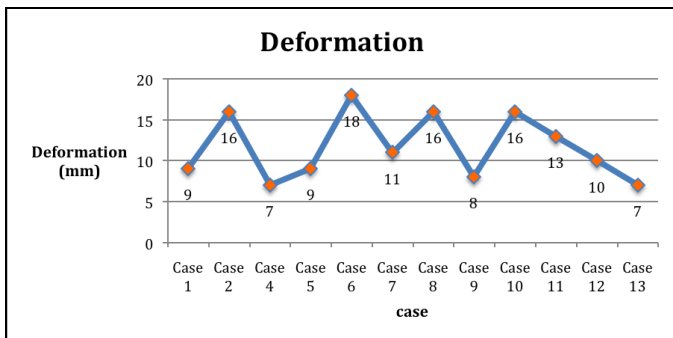

Fig.5 Deformation in each case

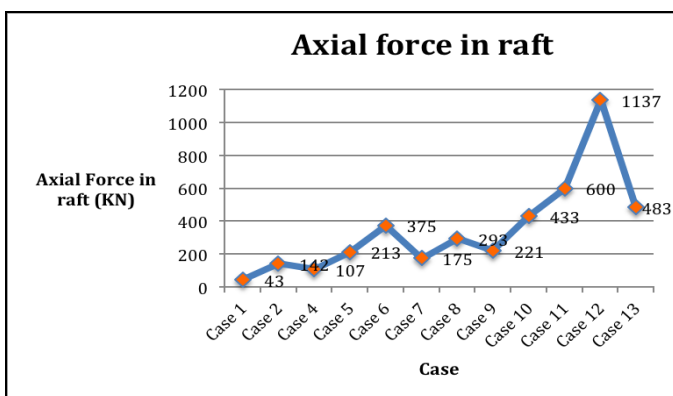

Fig.6 Axial force in raft

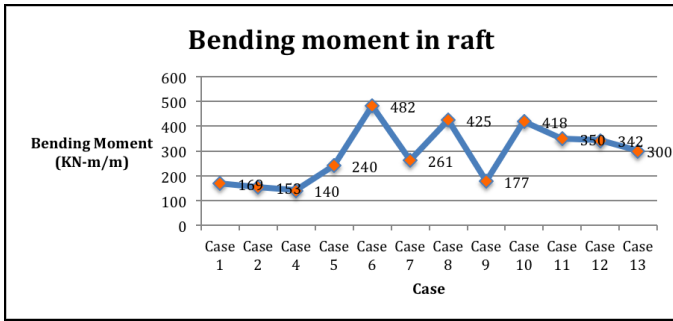

Fig.10 Bending Moment in Raft

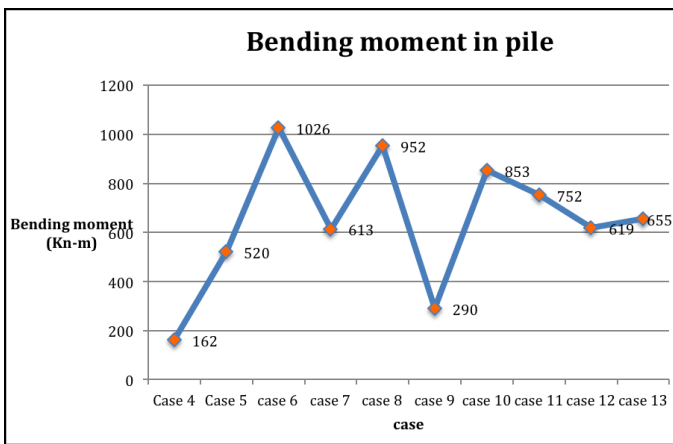

Fig.11 Bending Moment in Pile

5 CONCLUSIONS

- 1) When the horizontal load per pile exceeds what can be withstood by a vertical pile, battered piles are used in conjunction with vertical piles to improve the overall efficiency of the pile-soil system as they transmit the applied lateral loads partly in axial compression, rather than through shear and bending when only vertical piles are used.
- 2) Due to heavy lateral loads, batter piles are used for high-rise structures, retaining walls, and offshore structures like oil drilling platforms, rigs, jetties, and bridges.
- 3) A combined pile raft is efficient in withstanding inclined load rather than only a raft.
- 4) When the raft alone was modeled with vertical load and then inclined load, the deformation showed a 56.25% increment.
- 5) Piles were then taken into consideration to reduce deformation and other forces.

- 6) Foundation having batter piles in comparison to that having vertical piles showed a reduction of 61.1% in deformation.
- 7) Foundation having batter piles in comparison to that having vertical piles showed a reduction of 28.3% and 59.4% shear force in raft and piles respectively.
- 8) Foundation having batter piles in comparison to that having vertical piles showed a reduction of 37.75% and 36.15% bending moment in raft and piles respectively.
- 9) Thus, the optimum combination is a combined pile raft having batter piles at an angle of 30 degrees.
- 10) Further scope of research is to perform a parametric study on batter piles with a combination of vertical piles. The parameters shall be pile length, spacing, and diameter, raft thickness.

6 REFERENCES

- [1] Broms, B. B. (1964). "Lateral resistance of piles in cohesive soils." J. Soil Mech. Found. Div., ASCE, 90, 27-63.
- [2] Alizadeh, M., and Davisson, M. T. (1970). "Lateral load test on piles— Arkansas River Project." J. Soil Mech. and Found. Div., ASCE, 96, 1583 - 1603.
- [3] Georgiadis, M., Anagnostopoulos, A., and Saffekou, S. (1992). "Cyclic lateral loading of piles in soft clay." Geotech. Engrg., Bangkok, Thai- land, 23(1), 47-60.
- [4] Kondner, R. L. (1963). "Hyperbolic stress-strain response: Cohesive soils." J. Soil Mech. and Found. Div., ASCE, 89, 115-143.
- [5] Lu, S. S. (1981). "Design load of bored pile laterally loaded." Proc., 10th Int. Conf. on Soil Mech. and Found. Engrg., Balkema, Rotterdam, The Netherlands, Vol. 2, 767-770.
- [6] Matlock, H. (1970). "Correlations for design of laterally loaded piles." Proc., 2nd Offshore Technol. Conf., 577-593.
- [7] Matlock, H., and Foo, S. H. C. (1978). "Simulation of lateral pile behaviour under earthquake motion." Rep. to Chevron Oil Field Research Co., La Habra, Calif., Dept. of Civ. Engrg., University of Texas at Austin, Austin, Tex.
- [8] Meyerhof, G. G., and Ranjan, G. (1973). "The bearing capacity of rigid piles under inclined loads in sand II: Batter piles." Can. Geotech. J., Ottawa, 10, 71-85.
- [9] Murthy, V. N. S. (1964). "Behaviour of battered piles embedded in sand subjected to lateral loads." Proc., Symp. on Bearing Capacity of Piles, CBRI, Roorkee, India, 142-153.
- [10] Poulos, H. G., and Madhav, M. R. (1971). "Analysis of movement of battered piles." Res. Rep. No. R173, University of Sydney, Sydney, Australia, 1-18.
- [11] Prakash, S., and Subramanyam, G. (1965). "Behaviour of battered piles under lateral loads." J. Indian Nat. Soc. of Soil Mech. and Found. Engrg., New Delhi, 4, 177-196.
- [12] Veeresh, C. (1996). "Behaviour of batter piles in marine clays." PhD thesis, Indian Institute of Technology, Madras, India.
- [13] Saif Azhar (2020) " Parametric Study of pile raft foundation for high rise buildings"shri G.S Institute of Technology and Science, Indore, India