

# Control Of Three Phase BLDC Motor Using Fuzzy Logic Controller

Anjali. A. R

M-Tech in Powerelectronics & Drives, Calicut University

## Abstract

Brushless DC (BLDC) motor drives are becoming widely used in various consumer and industrial systems, such as servo motor drives, home appliances, computer peripherals and automotive applications in recent years because of their high efficiency, silent operation, compact form, reliability and low maintenance. The aim of this research is to design a simulation model of Permanent Magnet Brushless Direct Current (PMBLDC) motor and to control its position using fuzzy logic controller (FLC). In this proposed controller, mamdani method is used. In this project, a FLC for position control and BLDC motor are modeled and simulated in MATLAB/SIMULINK. Simulation results showed that fuzzy logic control provides more efficient closed loop response for position control of BLDC motor.

## 1. Introduction

BLDC motors are rapidly becoming popular in industries such as Appliances, HVAC industry, medical, electric traction, automotive, aircrafts, military equipment, hard disk drive, industrial automation equipment and instrumentation because of their smaller volume, high force, and simple system structure. Many machine design and control schemes have been developed to improve the performance of BLDC motor drives. In practice, the design of the BLDCM drive involves a complex process such as modeling, control scheme selection, simulation and parameters tuning etc.

Recently, various modern control solutions are proposed for the optimal control design of BLDC motor [1][2]. However, these methods are complex in nature and require excessive computation. In order to improve control performance of the BLDC motor drive, intelligence controllers such as fuzzy logic control for BLDC motor is used. Design objectives that are difficult to express mathematically can be easily incorporated in a fuzzy controller by linguistic rules. In addition, its implementation is simple and straight forward.

In this project, a complete simulation model with mamdani fuzzy logic control method for BLDC motor drive is proposed using Matlab/Simulink. Section 2 describes mathematical modeling and the driving circuitry of BLDC motor, section 3 explains the design of proposed controller using Mamdani method, section 4 gives the simulation results and section 5 concludes the paper.

## 2. Mathematical modeling

Figure 1 shows the basic building blocks of BLDC motor and its Driving circuitry.

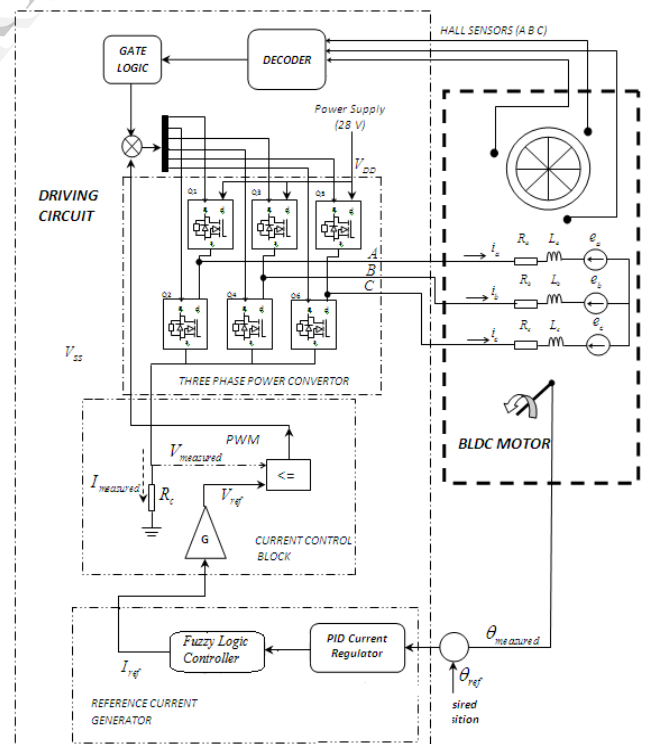

Figure 1. Block diagram of BLDC motor

The Y -connected, 3-phase motor with 8-pole permanent magnet rotor is driven by a standard three phase power convertor. The motor specifications are given in Table 1

**Table 1. BLDC motor specifications**

Number of poles	8
Stator resistance	0.0905 ohms
Stator inductance	0.115 MH
Rated torque	50 Nm
Rated speed	140 deg/sec
bandwidth	6-8 Hz
Supply voltage	28 V
Nominal current	11 A
Sampling period	10 μs
Friction constant	0.0001 Kg-ms/rad
Motor moment of inertia	0.000018395 Kg-ms <sup>2</sup> /rad

Figure 2 shows the complete Simulink model of three phase BLDC motor with its controlling and driving circuitry. The detailed description of the major blocks of BLDC motor is mentioned below.

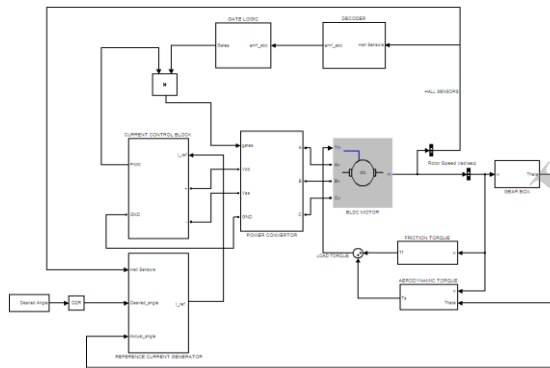

**Figure 2. Simulink model of BLDC motor**

**2.1. Electrical subsystem**

The electrical part of DC brushless motor and relationship between currents, voltage, and back electromotive force and rotor velocity is derived using Kirchhoff's voltage law [3]:

$$\begin{aligned}
 V_a &= R_a i_a + L_a \frac{di_a}{dt} + M_{ab} \frac{di_b}{dt} + M_{ac} \frac{di_c}{dt} + e_a \\
 V_b &= R_b i_b + L_b \frac{di_b}{dt} + M_{ba} \frac{di_a}{dt} + M_{bc} \frac{di_c}{dt} + e_b \\
 V_c &= R_c i_c + L_c \frac{di_c}{dt} + M_{ca} \frac{di_a}{dt} + M_{cb} \frac{di_b}{dt} + e_c
 \end{aligned}
 \tag{1}$$

**2.2. Mechanical subsystem**

A mathematical relationship between the shaft angular velocity and voltage input to the DC brushless motor is derived using Newton's law of motion [6].

$$J \frac{d\omega_r}{dt} = T_e - T_m - F\omega_r \tag{2}$$

The angular position is obtained from an integration of the angular velocity.

$$\theta_r = \int \omega_r dt \tag{3}$$

Generated electromagnetic torque for this 3-phase BLDC motor is dependent on the current, speed and back-EMF waveforms, so the instantaneous electromagnetic torque can be represented as:

$$T_e = \frac{1}{\omega_m} [e_a i_a + e_b i_b + e_c i_c] \tag{4}$$

**2.3. Description of driving circuitry**

Driving circuitry consists of three phase power converters as shown in Figure 3, which utilize six power transistors to energize two BLDC motor phases concurrently. The rotor position, which determines the switching sequence of the MOSFET transistors, is detected by means of 3 Hall sensors mounted on the stator. By using Hall sensor information, Decoder block generates signal vector of back EMF.

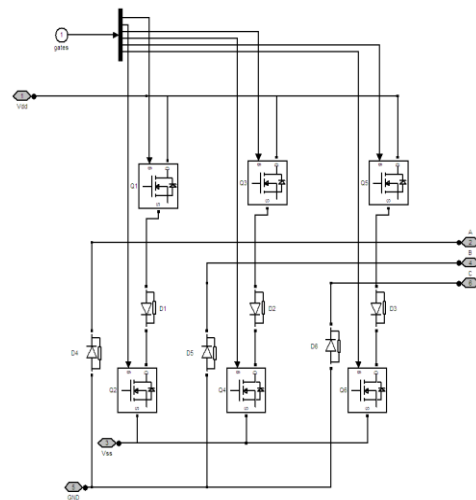

**Figure 3. Three phase power converter**

In **Reference current generator block**, fuzzy logic controller attempts to minimize the difference between desired angle and the actual measured angle by taking a corrective action to generate reference current signal.

In **current control block** shown in Figure 4, the reference current from current generator is transformed to reference voltage signal by using Ohm's law ( $V_{ref} = I_{ref} R$ ). This reference voltage is then compared with the measured voltage across control resistance  $R_c$ , where  $R_c = 0.01 \Omega$ . When the measured voltage is less than the reference voltage, control signal is set to one for  $t = 2T_s$ , where  $T_s$  is sampling time. In other case control signal is set to zero. In this way a pulse width modulated (PWM) signal having fixed frequency with variable duty cycle is obtained. This PWM signal is then multiplied with the output from gate logic to drive three phase Power Converter.

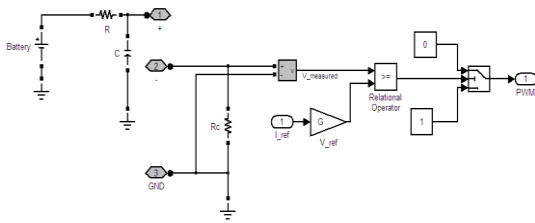

Figure 4. Current control block

**3. Design of proposed controller**

The structure of the proposed controller for BLDC motor is shown in Figure 5. The proposed controller consists of fuzzy logic controller for position control in the completed closed loop system. The designation of fuzzy logic controller is based on expert knowledge which mean the knowledge of skillful operator during the handling of BLDC motor system is adopted into the rule based design of fuzzy logic controller.

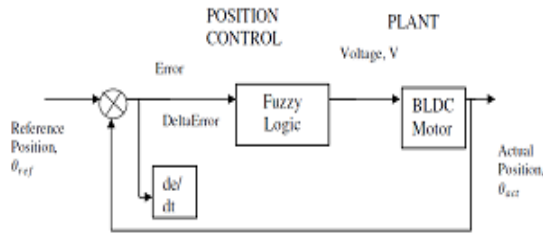

Figure 5. Proposed controller

There are four elements to be considered in order to design the fuzzy logic controller which are fuzzification interface, fuzzy rule, fuzzy inference mechanism and defuzzification interface.

**3.1. Fuzzification**

The most important step in fuzzification interface element is to determine the state variables or input variables and the control variables or output variables. There are two input variables for BLDC motor system in terms of position control which are error and delta of error. Error can be described as a reference of position set point minus actual position. Meanwhile, delta of error or change of error is error in process minus previous error. The voltage applied to the BLDC motor system is defined as output variable.

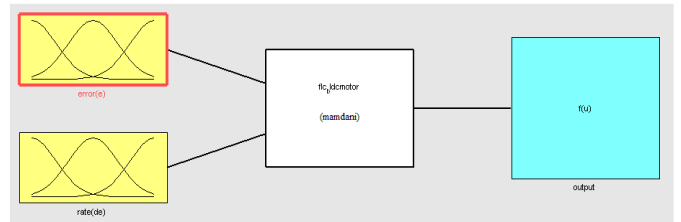
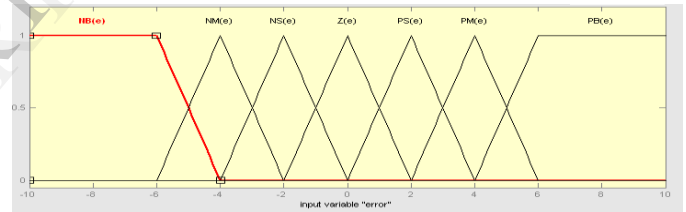
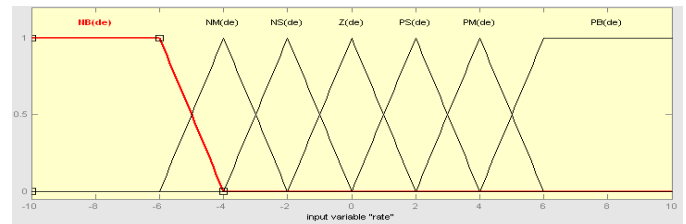

Figure 6. Membership function for input and output of fuzzy logic controller



(a) error(e)



(b) rate(de error)



(c) output

**Figure 7. Membership function for (a) input variable “error” (b) input variable “rate” (c) output variable ”output”**

The linguistic variables of the fuzzy sets need to be defined which are represent:

(i) Input variables:

• Error(e)

Quantized into 3, 5 and 7 membership function: Negative N(e), Negative Small NS(e), Negative Medium NM(e), Negative Big NB(e), Zero Z(e), Positive P(e), Positive Small PS(e), Positive Medium PM(e) and Positive Big PB(e).

• Rate(de error)

Quantized into 3, 5 and 7 membership function: Negative N(de), Negative Small NS(de), Negative Medium NM(de), Negative Big NB(de), Zero Z(de), Positive P(de), Positive Small PS(de), Positive Medium PM(de) and Positive Big PB(de).

(ii) Output variables:

• Output

Quantized into 5, 7 and 9 membership function: Negative Small (NS), Negative Medium (NM), Negative Big (NB), Zero (Z), Positive Small (PS), Positive Medium (PM) and Positive Big (PB).

**3.2. Fuzzy rule**

The basic function of the rule based is to represent the expert knowledge in a form of if-then rule structure. The fuzzy logic can be derived into combination of input (3 ×3, 5 × 5 and 7 × 7). The figure 8 shows the structure of rule editor.

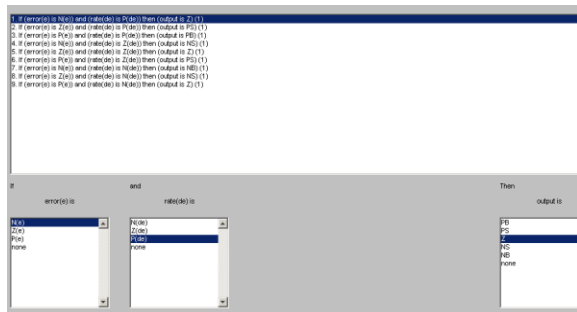
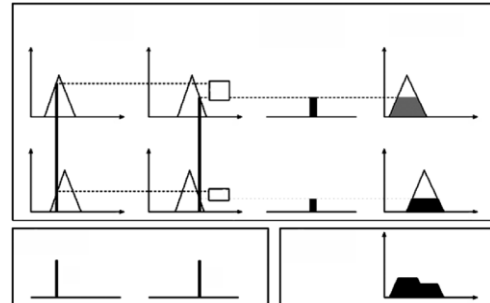

**Figure 8 . Structure of rule editor**

**3.3. Fuzzy inference mechanism**

In general, inference is a process of obtaining new knowledge through existing knowledge. In the context of fuzzy logic control system, it can be defined as a process to obtain the final result of combination of the result of each rule in fuzzy value. There are many methods to perform fuzzy inference method and the most common two of them are Mamdani and Takagi Sugeno Kang method.

Mamdani’s fuzzy inference method is the most commonly seen inference method which was introduced by Mamdani and Assilian (1975). An example of a Mamdani inference system is shown in Figure 9 .To compute the output of this FIS given the inputs, six steps has to be followed.



**Figure 9. A two input, two rule Mamdani FIS with crisp inputs**

1. Determining a set of fuzzy rules
2. Fuzzifying the inputs using the input membership functions
3. Combining the fuzzified inputs according to the fuzzy rules to establish a rule strength
4. Finding the consequence of the rule by combining the rule strength and the output membership function
5. Combining the consequences to get an output distribution
6. Defuzzifying the output distribution (this step is only if a crisp output (class) is needed).

Mamdani method is intuitive, widespread acceptance and well suited to human input.

**3.4. Defuzzification**

Defuzzification is a process that maps a fuzzy set to a crisp set and has attracted far less attention than other processes involved in fuzzy systems and technologies. Four most common defuzzification methods.

- Max membership method
- Center of gravity method
- Weight average method
- Mean-max membership method

MATLAB/Fuzzy Logic Toolbox is used to simulate FLC which can be integrated into simulations with Simulink. The FLC designed through the FIS editor is transferred to Matlab-Workspace by the command “Export to Workspace”. Then, Simulink environment provides a direct access to the FLC through the Matlab-Workspace in BLDC motor drive simulation.

#### 4. Simulation results

The simulation results includes variation of different parameters of BLDC motor like rotor angle, rotor speed, three phase stator currents, three phase back EMF's with respect to time. It is clear from the step response of the controlled system shown in Figure 10 performance with FLC is quite efficient, overshoot and settling time can be reduced.

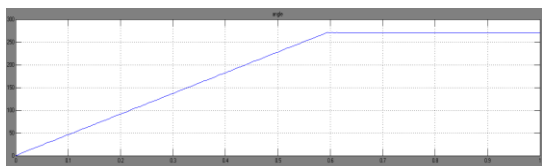

Figure 10. Rotor position in degree versus time

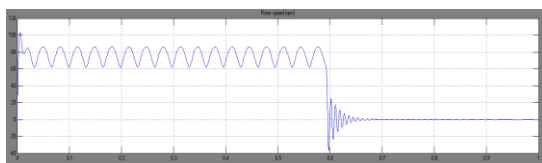

Figure 11. Speed versus time

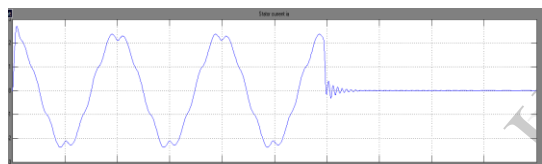

Figure 12. Phase A current variation

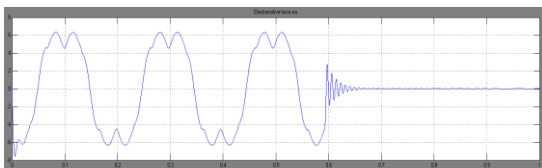

Figure 13. Phase A back EMF

#### 5. Conclusion

A fuzzy logic controller (FLC) has been employed for the position control of PMSBLDC motor drive and analysis of results of the performance of a fuzzy controller using mamdani method is presented. Simulation results showed that FLC control reduces overshoot and settling time and this controller also provides more efficient closed loop response for position control of BLDC motor.

#### 6. References

- [1] N. Hemati, J. S. Thorp, and M. C. Leu, "Robust nonlinear control of Brushless dc motors for direct-drive robotic applications," *IEEE Trans. Ind. Electron.*, vol. 37, pp. 460–468, Dec 1990.
- [2] P. M. Pelczewski and U. H. Kunz, "The optimal control of a constrained drive system with brushless dc motor," *IEEE Trans. Ind. Electron.*, vol. 37, pp. 342–348, Oct. 1990.
- [3] Atef Saleh Othman Al-Mashakbeh, "Proportional Integral And Derivative Control of Brushless DC Motor", *European Journal of Scientific Research* 26-28 July 2009, vol. 35, pg 198-203.
- [4] P. Yedamale, *Brushless DC (BLDC) Motor Fundamentals*. Chandler, AZ:Microchip Technology, Inc., last access; March15,2009.
- [5] M.v.Ramesh, J.Amarnath, S.Kamakshaiiah and G. S. Rao, "speed control of brushless dc motor by using fuzzy logic PI controller", *ARNP Journal of Engineering and Applied Sciences*, vol. 6, no. 9, september 2011
- [6] P.C Krause O. Wasynozuk, S.D.Sudhoff. *Analysis of Electric Machinery and Drive Systems*. IEEE Press, Second Edition.2002.
- [7] Mehmet Cunkas, Omer Aydogdu. *Realization of Fuzzy Logic Controlled Brushless DC MotorDrives Using Matlab/Simulink, Mathematical and Computational Applications*. 2010.Vol 15, (2), pp.218-229.
- [8] Rubaai. A., Marcel, J., Castro-Sitiriche and Abdul,R.Ofoli. *Design and Implementation of Parallel Fuzzy PID Controller for High Performance*.2008