

# Design And Optimization Of Multipurpose Tripple Band T-Slotted Microstrip Patch Antenna With DGS For Wireless Applications

<sup>1</sup> Sumit Kumar Jha  
Student (M.Tech, ECE) ACE, Ambala, Haryana, India

<sup>2</sup> Sukhwinder Singh Dhillon,  
Senior Assistant Professor, ECE Department ACE, Ambala, Haryana, India

<sup>3</sup>Sanjay Marwaha  
Professor, EIE Department SLIET, Longowal, Punjab

## Abstract

A single feed compact rectangular microstrip patch antenna for triple band application is presented in this paper. The proposed antenna has T slot on the patch and dumbbell shaped defected ground structure (DGS). To make the proposed antenna more efficient the optimization of the antenna design parameters have been done using HFSS's optometric. For the proposed antenna three resonant frequencies have been obtained at 2.30GHz, 5.15GHz and 6.64GHz with Bandwidth of 102Mz,216MHz and 353MHz return loss of -14.50db, -59.10db and -44.25db respectively. The characteristics of the designed structure are investigated by using FEM based electromagnetic solver, HFSS. An extensive analysis of the return loss, gain and bandwidth of the proposed antenna is presented. The simple configuration and low profile nature of the proposed antenna leads to easy fabrication and make it suitable for the application in wireless communication systems. Mainly it is developed to operate in the WLAN, WiMAX & RADAR application.

**Key Words:** Bandwidth, Returnloss, RADAR, Patch

## 1. Introduction

Microstrip antennas are very attractive because of their low profile, low weight, conformal to the surface of objects and easy production. A large number of microstrip patches to be used in wireless applications have been developed [1-3]. Design of WLAN antennas also got popularity with the advancement of microstrip antennas [4-5]. Wireless local area network (WLAN) requires three band of frequencies: 2.4GHz (2400-2484MHz), 5.2GHz (5150-5350MHz) and 5.8GHz (5725-5825MHz). WiMax has three allocated frequency bands. The low band (2.5-2.69GHz), the middle band (3.2-3.8 GHz) and the upper band (5.2-5.8GHz). Telecommunication via satellite and RADAR use the 4-8GHz band of frequency. The size of antenna is

effectively reduced by cutting slot in proper position on the microstrip patch. The use of DGS for size reduction of microstrip antenna, although its application have been reported for harmonic reduction [6], cross-polarization suppression [7] and mutual coupling reduction [8] in antenna arrays etc This paper presents the application of dumbbell shaped defected ground structure (DGS) in microstrip antenna for size reduction and to achieve useful multiband. While maintaining the antenna size, the broader operating bandwidth (BW)[9,10] is realized by cutting the slots of either half wave or quarter wave in length, having different shapes like U-slot, V-slot, L-slot, and a pair of rectangular slots inside the patch[11,12]. In this paper T-slot has been presented. The slot introduces a mode near the fundamental mode of the patch and realizes broadband response.

## 2. Antenna Design

The design of the conventional antenna is shown in figure 1(a). The antenna has 29mm x 25mm rectangular patch. The dielectric material selected for this design with  $\epsilon_r = 4.4$  and substrate height=1.57mm.

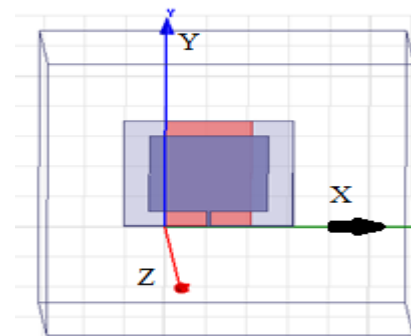

Figure 2(a). Conventional antenna Design

The above antenna has been designed using the transmission line model. Where the transmission line model is most accurate. To design the conventional rectangular micro strip patch antenna that operates at frequency around 2.45GHz, the dimensions can be found using [3]:

Design Specifications

Step 1: Determination of the Width (W)

The width of the Microstrip patch antenna is given by [3]

$$W = 37.26\text{mm.}$$

Step 2: Determination of effective dielectric constant ( $\epsilon_{\text{reff}}$ ).

The effective dielectric constant is represented by [3]. By substituting  $\epsilon_r = 4.4$ ,  $W = 36.26$  mm and  $h = 1.57$  mm, it can be determined that

$$\epsilon_{\text{reff}} = 4.4.$$

Step 3: Determination of the effective length ( $L_{\text{eff}}$ )

The effective length is given by [3]

By substituting  $\epsilon_{\text{reff}} = 4.4$ ,  $c = 3 \times 10^8$  m/s and  $f_0 = 2.45$  GHz, it can determine that

$$L_{\text{eff}} = 29.126 \text{ mm.}$$

Step 4: Determination of the length extension ( $\Delta L$ ) [3]

The length extension may be represented by

By substituting  $\epsilon_{\text{reff}} = 4.4$ ,  $W = 36.26$  mm and  $h = 1.57$  mm, it can be determined that

$$\Delta L = 0.01634 \text{ mm.}$$

Step 5: Determination of actual length of patch (L):

The actual length is obtained by using expression

$$L = L_{\text{eff}} - 2\Delta L$$

By substituting  $L_{\text{eff}} = 29.126$  mm and  $\Delta L = 0.01634$  mm, the actual length can determined as

$$L = 29.093 \text{ mm}$$

The actual length of the patch can be found using [3]:

Now the patch antenna has been improved with the T-slot on the rectangular patch which is shown in figure 2 (b) and the ground have been made defected with the dumble shaped defected ground structure as shown in figure 2(c). The dimension of T-slot as well as the dimension of the defected ground structure has been optimized to get the best result and a series of optimization has been done with HFSS optometric. The front view of the antenna shows the T-slot which is made by etching the patch. The defected ground structure has been made on the ground of the patch antenna which has dumble shape by etching the ground plane. The optimized antenna will work in the frequency range of 2-8GHz frequency band as it is shown in the figure 2(b) and 2(c) which covers the frequency of operation of WLAN, WiMAX, and wireless communication through satellite as well as

the frequency of operation of RADAR-that's why it is multipurpose microstrip patch antenna.

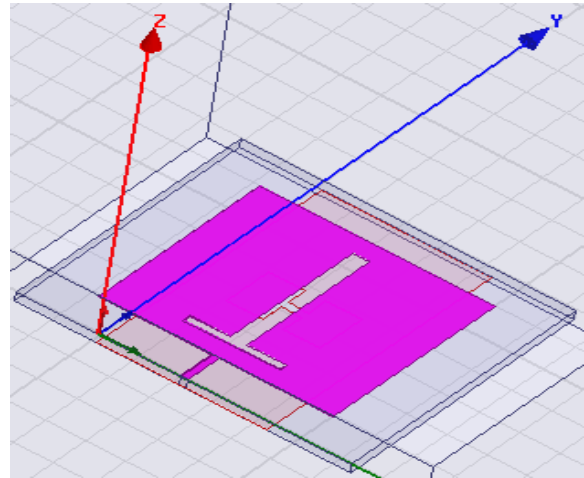

Figure 2(b): Rectangular patch antenna (Front View)

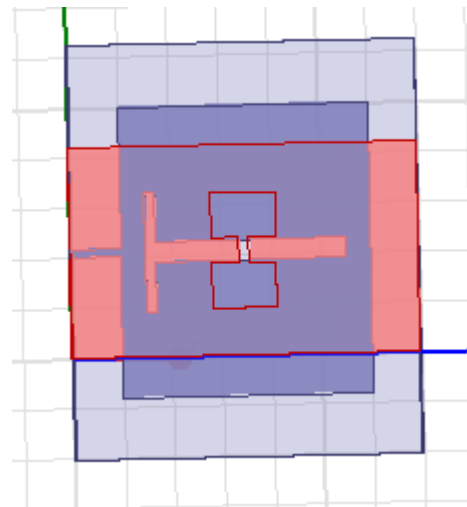

Figure 2(c): Ground of the antenna with DGS (Back View)

The dimension of the slot T as well as the dimension of the defected ground structure has been optimized to get the best return loss as well as the best bandwidth. The Optimized dimension of T-slot is given below:

Table: 1

Dimension of the T-shaped slot on the patch (Vertical slot)	2mm, 20mm
Dimension of the T-shaped slot on the patch (Horizontal slot)	1mm, 12mm

Now the optimized dimension of Defected Ground structure is given in the table below:

Table2

Dimension of the dumble shaped slot on the ground	6.5mm,4.5mm2.5 mm,1mm
---	-----------------------

### 3. Simulated Results & Analysis

Simulated (using HFSS 13.0) results of return loss of the conventional & proposed antenna is shown in figure2. A very significant improvement of frequency bandwidth has been obtained as compared to the conventional antenna after optimization

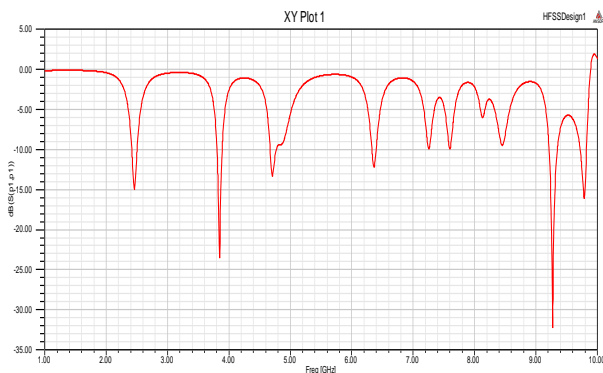

Figure 3(a): plot of return loss VS frequency of the conventional antenna.

Tables of analyzed bandwidth, frequency and Return loss have been made from the Figure 2(a) as shown below

Table3:

Frequency(GHz)	2.45	3.83	4.70	6.35	9.25	9.77
Bandwidth(MHz)	87	84	99	69	134	102
Return Loss(db)	-15.10	-23.70	-13.30	-12.20	-32.30	-16.20

Now the T- slotted with DGS have been optimized on various dimension of T-slot and DGS the combined waveform is shown in figure below

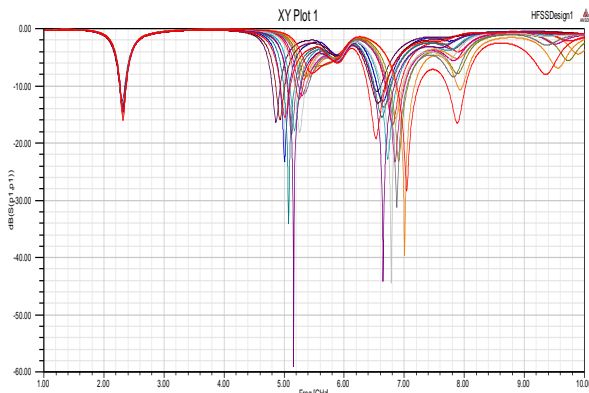

Figure3 (b): return loss VS frequency

From this plot the optimized dimension of the T-slot as well as the optimized dimension of DGS has been taken for the proposed microstrip antenna and the design has been simulated using the optimized data. The optimized data is given in the Table1 and Table2. The obtained plot is as presented below

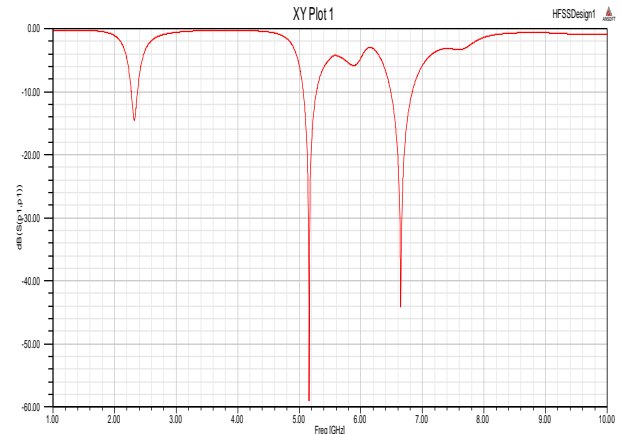

Figure 3(c): return loss VS frequency of the proposed antenna

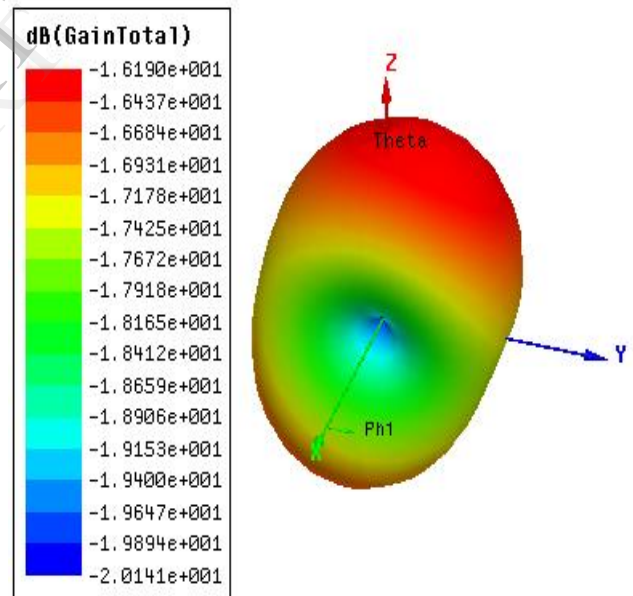

Figure 3(d): total gain of the proposed design

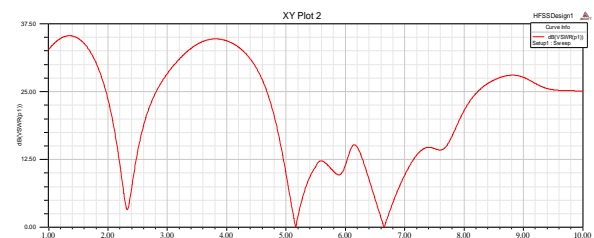

Figure 3(e): VSWR Plot of the proposed antenna

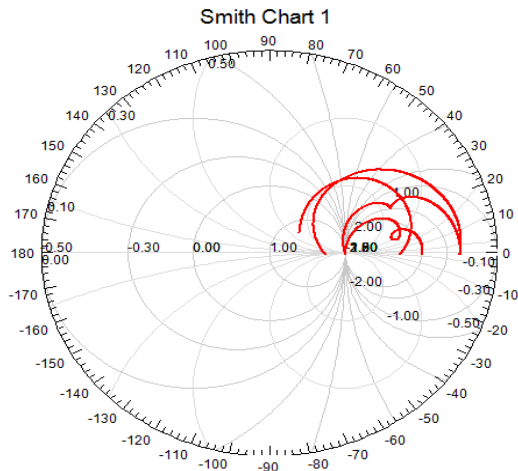

Figure 3(f): Smith chart plot of the proposed antenna

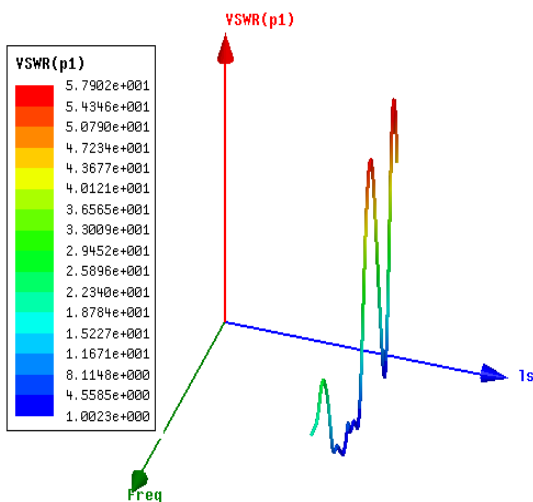

Figure 3(g): 3D rectangular plot VSWR (p1) of proposed antenna

**4. Conclusion**

Now from the above plots we can easily analyse the behaviour of the proposed antenna and hence we can analyse the Return loss as well as the bandwidth. The table4 below shows the analysed data.

This shows that the proposed antenna is far better in terms of bandwidth and return loss as compared to the antenna in literatures [13]etc.

Frequency(GHz)	2.30	5.15	6.64
Return loss(db)	-14.50	-59.10	-44.25
10db Bandwidth(MHz)	102	216	353

Hence this antenna is a good candidate for

applications where large bandwidth is required.

**5. References**

- [1] David Sinchez-Hemendez and Ian D. Robertson, "Analysis and Design of a Dual-Band Circularly Polarized Microstrip Patch Antenna" IEEE Transactions on Antennas and Propagation, issue 43, No2, February, 1995.
- [2] Ramesh Garg, Prakash Bhatia.et.al —Microstrip Antenna Design Handbookl Artech House antennas a propagation library,London,ISBN-0-89006-513-6,2001.
- [3] Constantine A. Balanis- Antenna Theory Analysis and Design, Second Edition, John Wiley & Sons (Asia) Pte Ltd. ISBN 9971-51-233-5,2001
- [4] S. Bhunia, M.-K. Pain, S. Biswas, D. Sarkar, P. P. Sarkar, and B. Gupta, "Investigations on Microstrip Patch Antennas with Different slots and Feeding Points" , Microwave and Optical Technology Letters, VOL 50, NO. 11, November 2008 pp 2754-2758.
- [5] D. N. Elsheakh, H. A. Elsadek, and E. A. Abdallah "Reconfigurable Single and Multi Band Inset Feed Microstrip Patch Antenna for Wireless Communication Devices" Progress In Electromagnetics Research C, Vol. 12, 191{201, 2010}.
- [6] H. W. Liu, Z. F. Li and X. W. Sun, "A Novel Fractal Defected Ground Structure for Microstrip Line," Journal of Active and Passive Electronic Devices, Vol. 1, 2006,pp. 311-316.
- [7] C. S. Kim, J. S. Park, D. Ahn and J. B. Lim, "An Improved 1-D Periodic Defected Ground Structure for Microstrip Line," IEEE Microwave and Wireless Components Letters, Vol. 10, No. 4, 2004, pp. 180-182.
- [8] Z. Li and Y. Rahmat-Samii, "PBG, PMC, and PEC Ground Planes: A Case Study of Dipole Antennas," IEEE Antennas and Propagation Society International Symposium, Vol. 2, 2000, pp. 674-677.
- [9] I.J. Bahl and P. Bhartia, Microstrip antennas, Artech House, 1980.
- [10] G. Kumar and K. P. Ray, Broadband Microstrip Antennas, First Edition, USA, Artech House, 2003.
- [11] T.Huynh , K. F. Lee, "Single-Layer Single Patch Wideband Microstrip Antenna," Electronics Letters, vol. 31, no. 16, August 1995, pp. 1310-1312.
- [12] R. Chair, K. F. Lee, C. L. Mak, K. M. Luk

and A. A. Kishk, "Miniature Wideband Half U-Slot And Half E Patch Antennas," IEEE Transactions on Antenna And Propagations, vol. 52, no. 8, August 2005, pp. 2645-2652.

- [13] Dalia M. Elsheakh, Esmat A. Abdallah , " Different Feeding Techniques of Microstrip Patch Antennas with Spiral Defected Ground Structure for Size Reduction and Ultra-Wide Band Operation" Journal of Electromagnetic Analysis and Applications, 2012, 4, 410-418, doi:10.4236/jemaa.2012.410056 Published Online October 2012.

Conference till september 2012. He is the author of Basic of Electrical Engineering and Basic of Electrical & Electronics Engineering; Satya Prakashan. He got his Ph.D. from Guru Nanak Dev University (GNDU) Amritsar in year 2000. M.E. (Power System) from Punjab Engineering College (PEC) Chandigarh in year 1990. B.E. (Electrical Engg.) from Madan Mohan Malviya Engg. College (MMMEC) Gorakhpur in year 1988.

### Author's Profile



Er. Sumit Kumar Jha is M.Tech (ECE) student at Ambala College of Engineering & Applied Research, Ambala. He got it his B.Tech in Electronics & Communication Engineering from SDDIET, Panchkula, Haryana in 2010. His area of interest is antenna, wireless and optical fibre communication and electromagnetic fields.



Er. Sukhwinder Singh was born in Ludhiana (Punjab). He Received B.Tech degree in Electrical Engineering from P.T.U, Jalandhar, Punjab, India and M.Tech. degree from Punjab Technical University, Jalandhar. His research interests includes Wireless and mobile communication, Microstrip antennas and Wind Energy Conversion Systems. He is currently working as an Senior Assistant Professor at Ambala College of Engineering and Applied Research, Devsthal, Ambala, Haryana, India and pursuing Ph.D. in EIE from SLIET, Longowal, Sangrur, Punjab, India



Dr. Sanjay Marwaha is professor of EIE Department in SLIET, Longowal, Punjab. He has more than 22 years of Teaching Experience and has published 27 National & International Journals. He has Attended 34 International Conference and 53 National