

## Design and Simulate Single Phase Inverter for Smoke Free Cars Used in Golf Course

J. Tavalaei, A. A. Mohd Zin, M. Moradi

Faculty of Electrical Engineering, Universiti Teknologi Malaysia

### Abstract

*It is a well-understood fact that power electronic converters and electric propulsion motors are extremely critical for every hybrid vehicle system. This work tried to simulate a single full bridge inverter and variation of voltage and frequency are assessed. Moreover, this simulation is not focus on boost transformer to increase the output voltage, yet output power and THD, tried to be constant for all changes. Keeping the above mentioned constrains in mind, the major focal of this structure is to maximum power delivery, in the lowest distortion voltage regulation and analyze the result of the simulation produce firing pulses with low harmonics. These simulations carry out by Pspice software and whole output analysis precisely.*

**Keywords:** Electric vehicle; Modelling; Pulse Width Modulation (PWM) inverters; MOSFET circuits.

Abdullah Asuhaimi Bin Mihd Zin is with Faculty of Electrical Engineering, 81310, UTM, Skudai, Malaysia. Tel: +607 5535366, Fax: +607 5566272, E-mail: abdullah@fke.utm.my.

### 1. Introduction

Nowadays, pollution due to exhaust carbon dioxide (CO<sub>2</sub>) from cars becomes more serious. Moreover, the crude oil demands and contains bounce up the price. Now, all the developed and developing countries desire to find new methods against these problems. One of the methods that apply to mitigate this problem is to use electrical hybrid vehicles which use less petrol [1].

From new investigation, for electrical vehicles, cars consumption varies from pure petrol and gasoline fuel to combination of petrol and electrical energy. Truly, there exist around 1,500,000 electrical car users around the world. The number of hybrid car users is increasing annually, by the rate of 40% and general increase seen for light-duty hybrids, such as sport utility vehicles and passenger's car. Although, the minority of these

vehicles are used for commercial, yet majority of them are deployed for personal transportation, generally for expressways or in the urban area. So, they used for different type of driving. As, the complexity of these cars increase every day, the method and measuring system evaluate their efficiency become more sophisticated. Exi Li et al. in reference [2] prove that hybrid electrical vehicle cannot be economically designed for all types of driving; because travel's types are not easily predictable. Furthermore, the electrical vehicle designers and manufacturers have tendency to use these vehicle for all type of load demands [2].

The significant parts of drive for AC motors are: mains drive inverter and other standard parts. Because of the cable and motor for electrical vehicles are used in industrial company, they are commercial components. One of the major problems seen in these systems, which produce powerful voltage in common mode in PWM inverters, is as following:

- Leakage current,
- Shorting of insulation lifetime,
- Conducted and radiated EMI.

In the reference [3], the modelling and suppression of negative effect of inverters are studied. Moreover, the elimination of conducted disturbances and other negative effects of PWM inverters are considered from the economic point of view.

Three phase induction motors are the most popular and usable machine in the industrial activities. Controlling of three phase motor is carried out by three phase inverter which control ac voltage and varies the frequency and output voltage (VVVF). The author in [4], used four switch inverter to drive this type of motor.

The speed of three phase induction motor is varied by three phase inverter which controls ac voltages as the variable frequency and variable voltage. However, references [4, 5] use four switch inverters to drive three phase motor. Four switch inverters can be called as two phase inverter. Two phase inverter is one of the low cost, small size and high reliability applicable inverter.

Inverters are devices used to convert dc to ac. They are widely used in industry for some applications such as induction furnaces, ac motor drives, uninterruptible power supply and in some renewable energy like wind plant and solar energy. The inverter converts input dc voltage to symmetrical ac output according to the desire frequency and voltage amplitude [6, 7]. The output voltage and frequency can be constant or variable. Ideally, the inverter output waveform should be sinusoidal and clear of harmonics. However practically, the waveform is not sinusoidal and consists of harmonics. In several applications harmonic does not cause problem such as induction motors. But in some cases high quality and pure sinusoidal waveform are required. For these cases low pass filter should be used to reduce harmonics even eliminate them while the fundamental component is being passed through the pass band.

## 2. Inverter Specification and Modelling

A single phase inverter is presented in figure 1. It includes two legs, each leg consist of two transistors which are in parallel with a diode. When transistor numbers 1 and 2 are turned on simultaneously, input voltage will appear across the load. Yet, third and fourth transistors are triggered together at the same time, appeared voltage in output is input voltage with negative sign. The outputs of PWM will trigger the gates of MOSFETs. However, low pass filter is applied for removing the harmful harmonics fed the load.

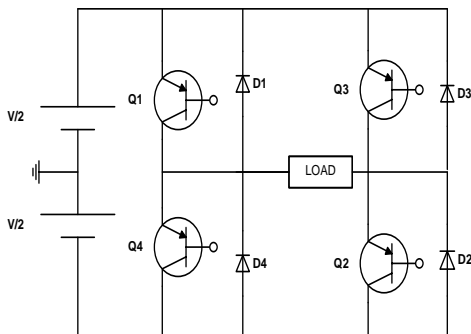

Fig1. The Single Phase Full Bridge Inverter

In order to increase the safety in outputs of PWM 1us delay is applied between trigger times which called dead-time. This interval period will prevent the MOSFETs to stay in conducting situation. Table 1 gives the single phase inverter parameter for smoke free golf course car. Maximum power need for running motor of car is not more than 1.5 kW and THD remains less than 5%. As it carries out for small and low speed

car, output voltage provides the desire level without using step up transformer. Here assume that the aforementioned motor is available and designers need to provide power with variable frequency and voltage, but constant power and low harmonic distortion. Moreover, load is purely resistive to easier model and control the model. For designing a PWM a carrier waveform and a modulating waveform are essential. Carrier wave is chosen as triangle waveform with frequency of 20k Hz, and the modulating wave is a simple 50 Hz sinusoidal waveform.

Table1. Single Phase Inverter Parameters for Principle

Input DC Supply	48V DC
Output AC voltage	Variable from 8 to 40V AC
Output AC frequency	Variable from 10 to 50Hz
Output power	Max. 1.5kWatt (pure resistive)
Output voltage THD	less 5%
Direct drive: no transformer required	

The PWM includes  $M_R$  and  $M_I$  which are modulation rate and modulation index, two important factors. The  $M_R$  is much important; because it determines the place of harmonics with the equation 1:

$$M_R = \frac{\text{frequency of carrier waveform}}{\text{frequency of reference waveform}} \quad (1)$$

Which,  $f_m$  is the frequency of modulating wave. This frequency is selected equal to 50 Hz. According to equation 1, first harmonic will start from 50 Hz.

$$f = kM_R f_m \quad (2)$$

And, the modulation index which is obtained from the amplitude of reference frequency over carrier frequency as follow:

$$M_I = \frac{\text{Amplitude of reference waveform}}{\text{Amplitude of carrier waveform}} \quad (3)$$

Variation in load resistance is calculated based on equation 3. This is because of because control the current at load side, load calculation and output power are easier while using resistor.

$$R_{Load} = \frac{V_{Load}^2}{P_{out}} \quad (4)$$

Moreover the THD of voltage impose unwanted signal rate in output, therefore, in this paper cope with 5% to have more ideal sinusoidal. THD calculated as the following:

$$THD = \frac{\sqrt{\sum_{n=2}^{\infty} V_n^2}}{V_1} \tag{5}$$

The THD expressed the sum of the amplitude of signals of all harmonic components over the amplitude of signal of the fundamental frequency.

### 3. Result and Simulation

The single full bridge inverter for smoke free golf course is shown in figure 1. The system includes 4 MOSFETs which are parallel with Diodes to protect MOSFETs during faults. DC voltage of system is divided into two 24 volt DC sources with neutral point at middle to have better voltage regulation . In the first part, switching results are illustrated and then on the next part results of simulation are discussed for various changes in voltage amplitude and frequency of reference voltage. Illustrated voltages are after filtering, but harmonic cluster alteration demonstrated before and after filtering, and finally average power will be discussed.

#### A. Switching results

In order to produce unipolar pulses, two sinusoidal reference waveforms are compared with a triangular carrier waveform and provide two series pulses. One for positive half cycle with amplitude  $V_d$  and other for negative half cycle with amplitude  $-V_d$ . ETABLE in this circuit (figure 2) works as an ideal OPAMP which never goes to saturation. The output of the ETABLEs straightly connected to the gate of MOSFETs. The MOSFETs are selected as IRF130. The feature of IRF130 and used tabular are shown at Appendix. The output of MOSFETs must be filtered because it contains harmful harmonics; so, a LOW-PASS filter is installed after MOSFETs to get sinusoidal waveform at the output of the filter.

This type of switching contains two sinusoidal waveforms (yellow and green) which have 180 degree difference in phase and is shown in figure3.

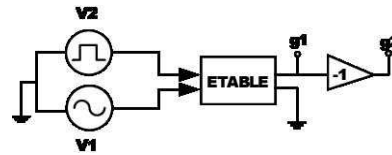

Fig2. Unipolar switching circuit

Trigger pulse for MOSFETs provide these two sinusoidal waves. Adjusting a delay at starting of waveform due to design of PWM will cause voltage drop; furthermore, controlling dead time. While dead time which is applied in switching the pulse width in PWM is decrease; so, the period of conducting the MOSFETs will decrease as well as the output voltage. Figure1 portrays unipolar switching pulse use to provide AC waveform from Battery. A low pass filter settled at the output of circuit and the load is purely resistive, because control the current at load side is easier while using resistor. Yet, adding any inductive component, residual current dominant on switching and current feeding.

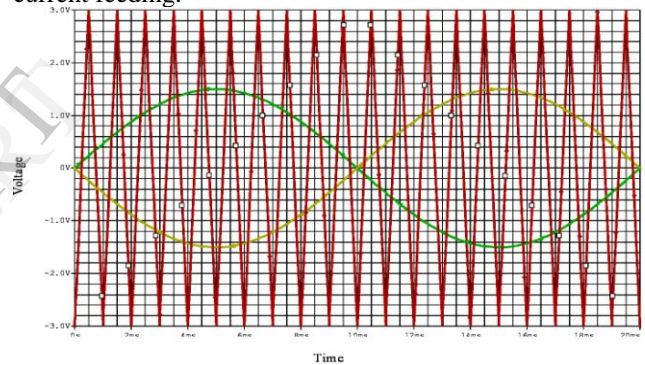

Fig.3 Carrier and modulation waveform unipolar modulation

#### B. Variation of Voltage

In this part the value of voltage, harmonic and power will be shown for four different simulations. First, the voltage is 40 volt, yet it changes to 33 volt in the next step, 22 volt and finally reduces to 8 volt; respectively. By using equation 4 the value for the resistor is calculated for all different voltages. The outcomes of changes in output power will significant change in load.

Table2. Changes in Voltage

Voltage (V)	Calculated Load (Ω)	Output Power (W)
40	1.067	500
33	0.73	600
22	0.323	700
8	0.043	750

After switching the MOSFETs the output voltage consists of many upper and undesired harmonics. In

this paper this harmonics omit by an ideal Low-Pass filter which the cut-off frequency for better answer settled at 70 Hz. The output voltage of this filter portray in figure4. Exerting Fast Fourier transform to extract voltage before filtering the harmonic cluster obtained (fig.5), this cluster illustrate fundamental and upper harmonics. Figure 6 shows the result after filtering of unwanted harmonics. Because there is no integer coefficient of fundamental harmonic in the output voltage after filtering, THD is zero; therefore the total harmonic distortion will be zero. Figure 7 portrays the average of output power will reach to steady-state stage. Although the output power always has fluctuation waveform; but the average is constant which is prepared for resistive load. As output voltage is structured by cumulative step waves, researchers try to make it more sinusoidal to have better output power; yet always average power is discussed instead of instantaneous one for feeding loads.

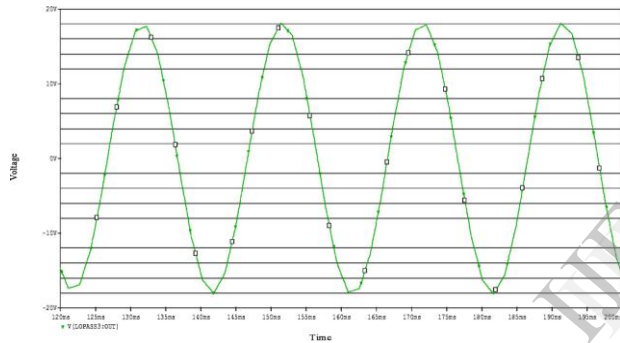

Fig4. Output voltage after filtering (40V & 50Hz)

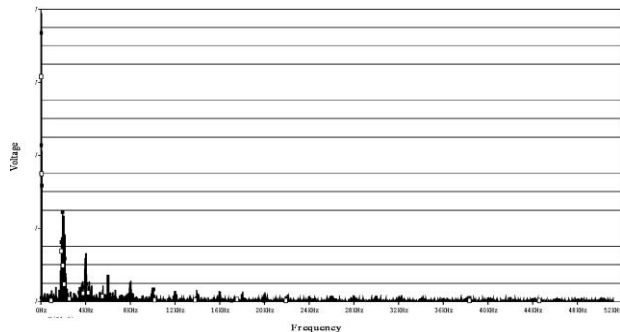

Fig5. Harmonic cluster before filtering (40V & 50Hz)

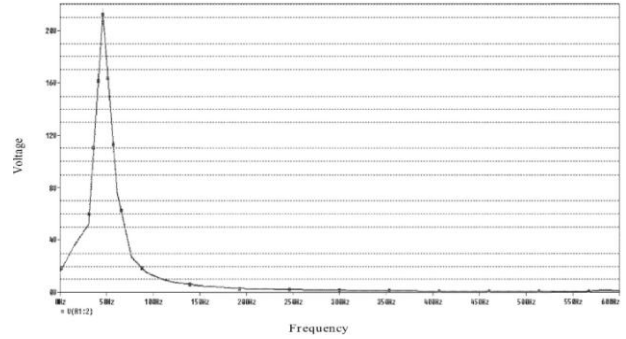

Fig6. Harmonic cluster after filtering (40V & 50Hz)

By changing the voltage, the value for the resistor will be changed based on the equation.4, yet the value of the average output power reduced. Moreover, the harmonics cluster magnitude drop off. But the models of all the output are the same as the figure 2, but the scale is reduced. The THD for all other simulation is not changed although the cut-off frequency for each simulation had a bit change. In table.2, the simulation resultant for voltage, load value and output power listed.

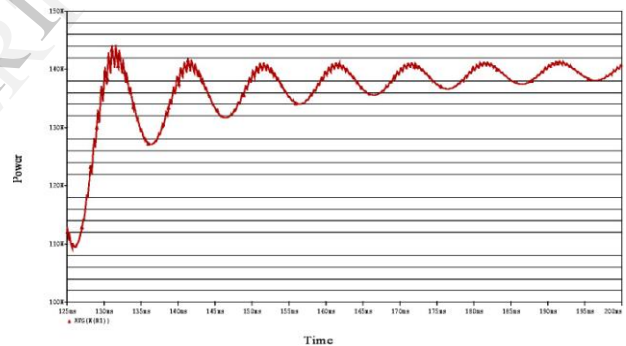

Fig7. Output power (40V & 50Hz)

### C. Variation of Frequency

The result of previous simulation is used as reference to compare the effect of frequency changes. The inverter can feed a smoke free car at 40 Volt, and consumes 500 Watt energy for moving in golf course. However, by changing in frequency, the reference frequency reduced to 27 Hz to reduce the undesired harmonic filtering of cut-off frequency must be change. Furthermore, the upper harmonics are coefficient of 27 Hz, so the new cut-off frequency settled at 35 Hz.



Table3. Vary the Modulation Index  $M_I$

$M_I$	Voltage (V)	Power (W)
0.66	32	600
0.5	24	650
0.33	16	710
0.16	8	710

As it illustrated in the fig8 and fig.9, just the fundamental harmonic of voltage change, yet Upper harmonics will appear as coefficient of 27Hz; but the power remains constant. Now, the effect of modulation index  $M_I$  changes and varies in voltage and power examine and chart at table3.

All the values shown in table3 are extracted from figures 10 to 13. These figures are consisting two parts. Upper part shows average of output power and voltage after filtering at the below one. Changing modulation index  $M_I$  from 0.66 to 0.16; the output power varies from 600 watt to 710 watt. Moreover, the voltage has opposite relationship with modulation index; that voltage is decreasing from 32 when  $M_I=0.66$  volt to 8 volt  $M_I=0.16$ . The above simulations showed that selecting the best voltage and frequency can significantly bounce up the output power of inverter which feed a simple motor of golf course car. Switching and filtering of unwanted harmonics is effective on adjustment of output power. Finally, load is using average power instead of instantaneous power.

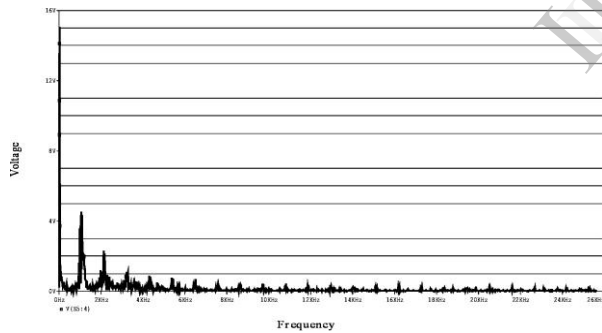

Fig8. Harmonic cluster before filtering (40V & 27Hz)

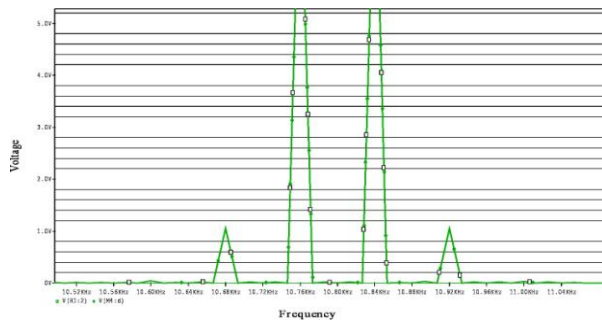

Fig9. Harmonic cluster before filtering (40V & 27Hz)

#### 4. Conclusion

In conclusion, since generated pulses to trigger switches appear in output, are used the unipolar switching method, those should be in high quality. It means in order to have output waveform with low harmonics; the firing pulses should include low harmonics. To achieve this goal,  $M_R$  should be selected as odd number. This causes use even harmonics elimination, so third and fifth harmonics can be removed by choosing good filter.

The Output voltages after filtering have good THD, so the existences of higher harmonics are not significant. Although the instantaneous output power is not constant, but the load has been used average power. So, after obtaining average power, prove that it is constant. There is reduction in fundamental component of the output waveform that is equal  $M_I$  times input voltage.

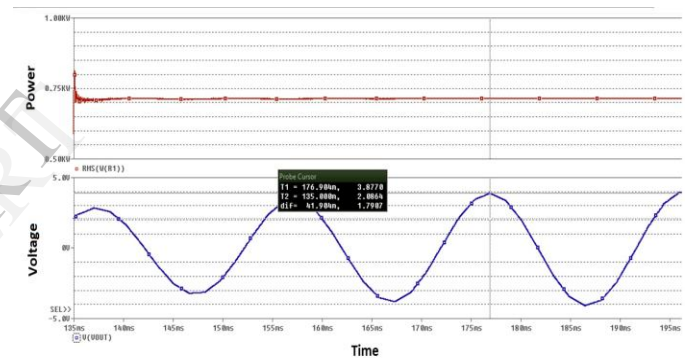

Fig10. Output power and Voltage for  $M_I = 0.66$

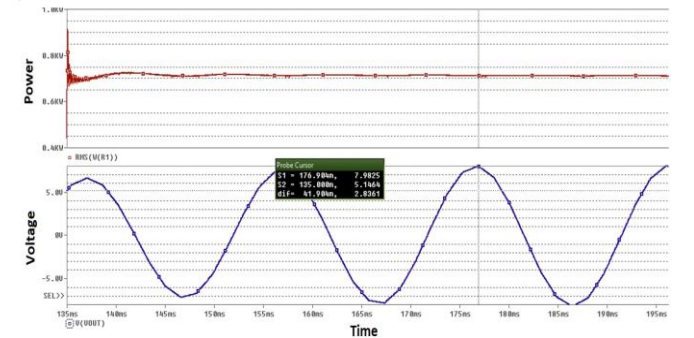

Fig11. Output power and Voltage for  $M_I = 0.5$

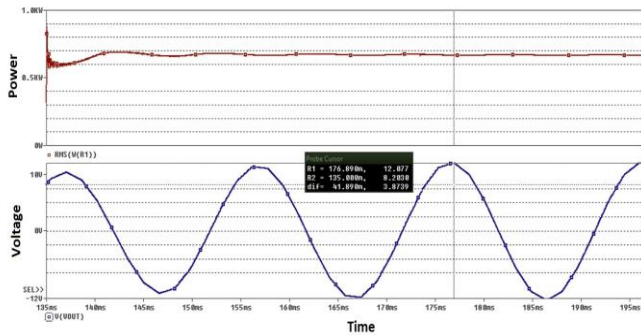

Fig12. Output power and Voltage for  $M_1=0.33$

**5. Acknowledgement**

The authors would like to thank Universiti Teknologi Malaysia for the financial and management support provided for this work.

**6. Appendix**

IRF-130 Power MOSFET applied data in this simulation. In table A.1, essential operation time and recovery for physical characteristic is portrays. In figure A1 the switching time for resistive loads extract from data sheet.

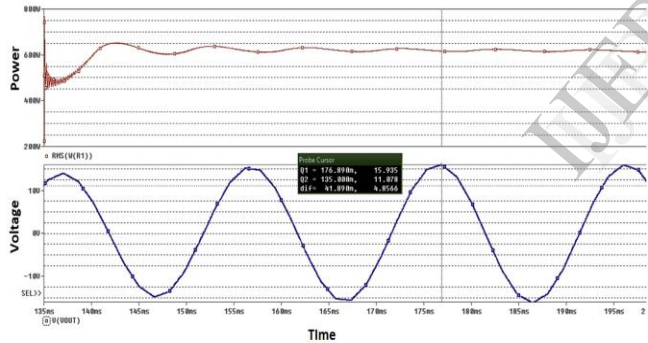
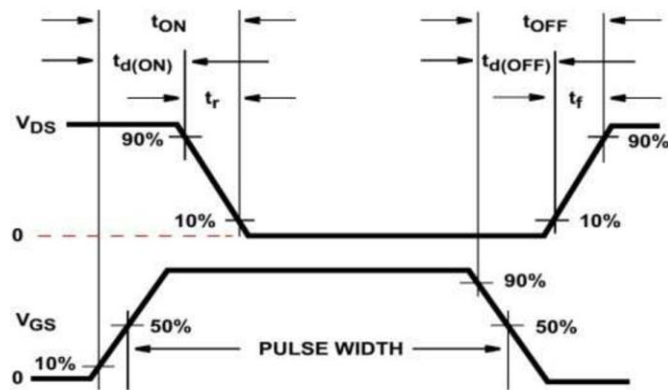

Fig10. Output power and Voltage for  $M_1=0.16$



FigA.1. Resistive Switching Waveform

Using this graph and the data in table A.1, the minimum dead time for switching find out is 1us.

**TABLE A.1 MOSFET SWITCHING TIMES**

MOSFET Switching Times are Essentially Independent of Operating Temperature	
Continuous current	14A
VDD	50V
Turn On Delay Time	Max. 30 ns
Rise Time	Max. 75 ns
Turn-Off Delay Time	Max. 40 ns
Fall Time	Max. 45 ns
$R_G$	12Ω
$R_L$	3.5Ω

**7. Reference**

[1]. T. Ono, T. Murata, J. Tamura, and T. Tsuchiya, "Modeling of pwm inverter fed ipmsm drive system and its application to hybrid vehicle," in Electrical Machines, 2008. ICEM 2008. 18th International Conference on, pp. 1–6, 2008.

[2]. X. Li and S. Williamson, "Efficiency analysis of hybrid electric vehicle (hev) traction motor-inverter drive for varied driving load demands," in Applied Power Electronics Conference and Exposition, 2008. APEC 2008. Twenty-Third Annual IEEE, pp. 280–285, 2008.

[3]. Esmaeli, B. Jiang, and L. Sun, "Modelling and suppression of PWM inverter's adverse effects," in Systems and Control in Aerospace and Astronautics, 2006. ISSCAA 2006. 1st International Symposium on, pp. 5 pp.–1454, 2006.

[4]. S. Jangjaempradit and M. Morimoto, "Two phase inverter drive of three phase motor," in Power Electronics and Drive Systems, 2007. PEDS '07. 7th International Conference on, pp. 1492–1495, 2007.

[5]. J. Ewanchuk, J. Salmon, and A. Knight, "Performance of a high-speed motor drive system using a novel multilevel inverter topology," Industry Applications, IEEE Transactions on, vol. 45, no. 5, pp. 1706–1714, 2009.

[6]. K. Shigematsu, T. Koga, S. Hasumura, A. Yamanaka, and T. Abe, "A study of common mode current reduction in pwm inverter with core modelling and system simulation," in Power Electronics and Applications, 2009. EPE '09. 13th European Conference on, pp. 1–8, 2009.

[7]. T. Maris, S. Kourtesi, L. Ekonomou, and G. Fotis, "Modelling of a single phase photovoltaic inverter," Solar Energy Materials and Solar Cells, vol. 91, no. 18, pp. 1713 – 1725, 2007.