

# Design and Structural Analysis of Single Plate Friction Clutch

Mr. Vishal J. Deshbhratar \*, Mr. Nagnath U. Kakde \*\*

\*Assistant Professor, Department of Mechanical Engineering  
Vidarbha Institute of Technology, Umrer road, Nagpur

\*\* Assistant Professor, Department of Mechanical Engineering  
Dr. Babasaheb Ambedkar college of Engg. And Research, Nagpur

## Abstract

*In design of the friction clutches of automobiles, knowledge on the thermo-elasticity a priori is very informative in the initial design stage. Especially, the precise prediction technique of maximum structural stress should be requested in design of mechanical clutches for their durability and compactness.*

*In this study, an efficient and reliable analysis technique for the design of the mechanical clutches by using computer modeling and numerical method is developed. This work contains stress analysis of single plate clutch of the automobile, in which the stresses and forces developed in the clutch is tried to reduce with the help of software approach. The detail study of clutch and modeling of clutch is done in pro-e software and the analysis is to be done in Ansys software. Also in this work efficient and reliable design of mechanical clutch is find out.*

**Keywords:-** Clutch, Structural Analysis, Ansys

## 1. Introduction

Clutch is a device used in the transmission system of a vehicle to engage and disengage the transmission system from the engine. Thus, the clutch is located between the engine and the transmission system. In a vehicle, the clutch is always in the engaged position. The clutch is disengaged when starting the engine, when shifting gears, when stopping the vehicle and when idling the engine. It is disengaged by operating the clutch pedal i.e. by pressing the pedal towards the floor of the vehicle. The clutch is engaged when the vehicle has to move and is kept in the engaged position when the vehicle is moving. The clutch also permits the gradual taking up of the load, when properly operated; it prevents jerky motion of the

vehicle and thus avoids putting undue strain on the remaining parts of the power transmission

## 2. Single plate friction clutch

The parts of a single plate clutch can be seen below. It has only one clutch plate, mounted on the splines of the clutch shaft. This is the most commonly used type.

The flywheel is mounted on the crankshaft, and rotates with it. The pressure plate is fixed on the flywheel through the pressure plate is fixed on the flywheel through the clutch springs. The plate rotates freely on the clutch shaft. It can also be moved axially along the clutch shaft. The axial movement of the pressure plate is effected by pressing the clutch pedal. The end of the clutch shaft rests and rotates freely in the pilot bearing housed at the centre of the flywheel.

The splined portion of the clutch shaft carries the clutch plate whose details are shown in the figure.

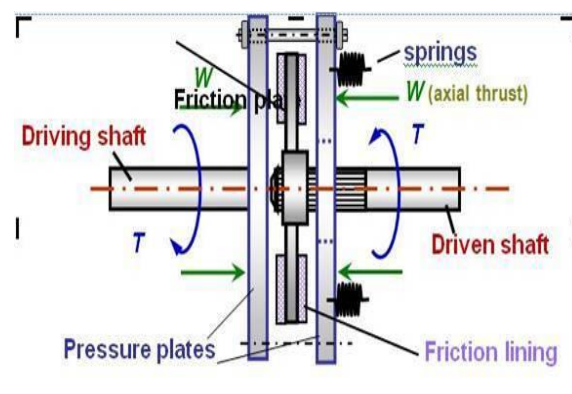

Fig 1. Single Plate Friction Clutch

The clutch plate consists of two sets of facings of friction material mounted on steel cushion springs.

The facings and the waved cushion springs are riveted to a spring base disc and spring retainer plate. The waves of the cushion springs compress slightly as the clutch engages and thus provide some cushioning effect. The base disc and the spring retainer plate are slotted for inserting the torsion springs. These torsion springs contact the hub flange that fits between the spring retainer plate and the disc. The principle of this device is that the driven plate is not rigidly connected to the hub of the driven shaft but left free rotationally thereon and is connected through a number of small spring's blocks. As such, these torsion springs serve to transmit the twisting force applied to the facings, to the splined hub. The spring action serves to reduce tensional vibrations and shocks between the engine and the transmission during clutch operation. By this arrangement, certain tensional vibrations of the crankshaft that have given rise to noise in the gear box are damped out and noise is eliminated.

When the clutch gets engaged, the facings and the plates rotate with respect to the hub to the limit of the compression of the torsion springs or to the limit of the springs stops. When the clutch is engaged, the pressure on the facing compresses the cushion springs sufficiently to cause the unit to decrease in thickness by 1.0 to 1.5 mm. This construction helps clutch engagement to be smooth and chatterless.

The single plate clutch in the engaged from as well as in the disengaged from can be seen in Fig. Due to the clutch spring force, the clutch plate is gripped between the flywheel and the pressure plate. Due to friction between the flywheel and clutch plate and the pressure plate, the clutch plate revolves. The clutch shaft which carries the plate also revolves. Clutch shaft is connected to the transmission. Thus, the engine power is transmitted from the crankshaft to the transmission unit.

### 3. Clutch Plates in Heavy Vehicles

In vehicles there are one or more friction discs that are joined together or pressed against a flywheel using springs. Clutch plates found in trucks and speed cars are made of ceramic. When the clutch pedal is depressed the spring pressure is released pushing or pulling the diaphragm of the pressure plate. Thus, the friction plate is released and allowed to rotate freely. The clutch plate is used to increase or decrease the speed of a vehicle. However, increasing the engine speed too high engages the clutch. This, in turn, causes excessive clutch plate wear. There are two types of clutches available- wet and dry. While the wet clutch is bathed in a cooling lubricating fluid, a dry clutch is not. A wet clutch gives good quality performance

and lasts long due to the clean surfaces. But, they lose some energy to the liquid and can be slippery.

### 4. Clutch Plates in Automobiles and Motorcycles

Clutch plate in a car is controlled by the left-most pedal. This makes use of hydraulics or a cable connection. The clutch may be physically located in close proximity to the pedal, but remote means of actuation are required to remove the effect of slight engine movement. If there is no pressure on the pedal, it means that the clutch plates are engaged. It gets disengaged once the clutch pedal is depressed. Cars can also function with manual transmission. In this there are cogs that have matching teeth to synchronize the speed. One can select gears with the help of these cogs. In motorcycles, the clutch is operated by the clutch lever. One can engage the clutch plate by applying no pressure on the lever. Pulling the lever back towards the rider disengages the clutch plates. Slipper clutch plates are often used by racing motorcycles to get rid of engine braking.

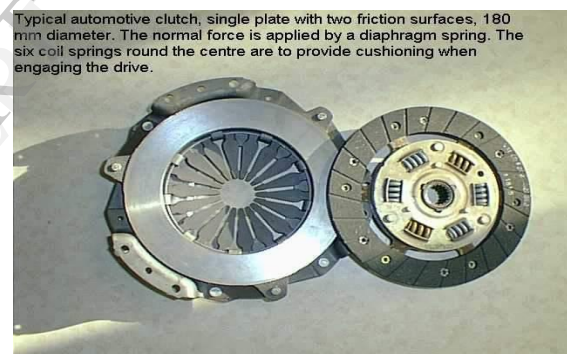

Fig 2. Pressure Plate and clutch Plate in Automotive clutch

### 4. Structural Analysis

Structural analysis comprises the set of physical laws and mathematics required to study and predicts the behavior of structures. The subjects of structural analysis are engineering artifacts whose integrity is judged largely based upon their ability to withstand loads; they commonly include buildings, bridges, aircraft, and ships. Structural analysis incorporates the fields of mechanics and dynamics as well as the many failure theories. From a theoretical perspective the primary goal of structural analysis is the computation of deformations, internal forces, and stresses. In practice, structural analysis can be viewed more abstractly as a method to drive the engineering design process or prove the soundness of a design without a dependence on directly testing it.

It consists of linear and non-linear models. Linear models use simple parameters and assume that the material is not plastically deformed. Non-linear models consist of stressing the material past its elastic capabilities. The stresses in the material then vary with the amount of deformation.

It includes the following methods,

- 1) Analytical Methods
- 2) Strength of materials methods (classical methods)
- 3) Finite element methods (FEM)

## 5. Modelling of Clutch

### Specification:

Model- TATA 475 IDITC

Maximum power - 51.5 kW @4800rpm

Maximum torque- 124 Nm @ 2800rpm

Capacity-1405cc

### Clutch kit:

#### 1) Pressure plate:

Internal diameter = 200mm

Pressure plate Outer diameter = 230mm

Rim diameter= 30mm

#### 2) Clutch plate

Material: Structural steel

External diameter= 230mm

Width=9mm

#### 3) Flywheel

External diameter= 260mm

No. of teeth=122

#### 4) Spring;

Length=40mm

Outer diameter = 16mm

Inner diameter= 15mm

#### 5) Release bearing;

Outer diameter=44mm

Inner diameter-30mm

Hook distance=75mm

### 7.2 Calculations

Outer diameter ( $D_o$ ) = 230 mm

Inner diameter ( $D_i$ ) = 200 mm

No. of spring = 9

$\mu = 0.35$

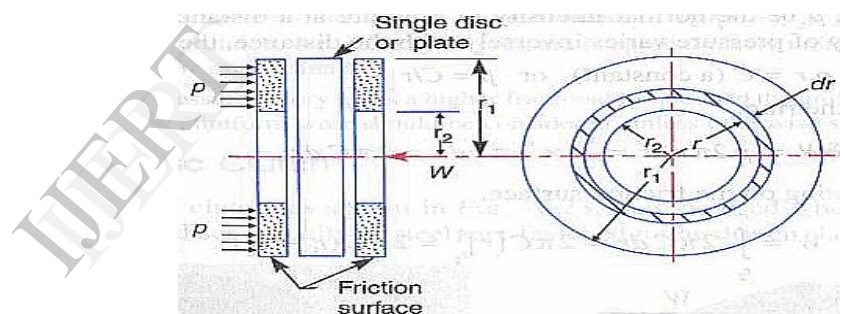

Fig 3. Diagrammatic representation of clutch plate

$$r_1 / r_0 = 100 / 115$$

$$= 0.869$$

$$F_a = 9 \times 625$$

$$= 5.625 \text{ KN}$$

Torque Capacity of New Clutch (T),

$$\tau = \frac{2}{3} \cdot \mu W \times \frac{R^3 - r^3}{R^2 - r^2} * N_f$$

$$= \frac{2}{3} \times 0.3 \times 5625 \left( \frac{0.115^3 - 0.13^3}{0.115^2 - 0.13^2} \right) \times 2$$

$$= 363.401 \text{ N-m}$$

$$= 0.363401 \text{ kN-m}$$

Torque Capacity after Initial Wear,

$$\begin{aligned} T &= u F_a D_m N_f / 2 \\ &= 0.3 \times 5625 \times (230+200/2) \times 2 / 2 \\ &= 362.81 \text{ N-m} \end{aligned}$$

Safety Factor when New =  $T / 124$

$$\begin{aligned} &= 363.401/124 \\ &= 2.930 \end{aligned}$$

Safety Factor after initial wear =  $362.810/124$

$$= 2.925$$

Reduction in clamping force so that Slippage Occurs,

New Clamping Force

$$\begin{aligned} F_a^1 &= 5.625 \times 10^3 \times 124 / 362.81 \\ &= 1.9224 \text{ KN} \end{aligned}$$

Change in Clamping Force,

$$\begin{aligned} F_a^2 &= 5.625 - 1.9224 \\ &= 3.703 \text{ KN} \end{aligned}$$

Change in Clamping Force of each spring,

$$\begin{aligned} &= 3.703/4 \\ &= 0.9257 \text{ KN} \end{aligned}$$

Spring Stiffness =  $625/6.5$

$$= 96.15 \text{ N/mm}$$

Required Wear =  $925.7 / 96.15$

$$= 6.928 \text{ mm}$$

For design of spring:

Max. Force =  $625 \times 1.1$

$$= 687.5 \text{ N}$$

(10% extra force for disengagement)

Spring stiffness =  $96 \text{ N/mm}$

For automotive clutch springs, select Cr-V Steel

SAE.6150

Allowable Shear Stress with a F.S. = 1.2

$$\tau_{\max} = S_{ys} / 1.2$$

$$S_{ys} = 770$$

$$\tau_{\max} = 770 / 1.2$$

$$= 641 \text{ Mpa}$$

Assuming Wahl Factor,  $C = 6$

$$K = ((4X6 - 1) / (4X6 - 4)) + (0.615/6)$$

$$= 1.25$$

$$\tau_{\max} = 8F_{\max} \cdot D_m K / \pi d^3$$

$$= 8FCK / \pi d^2$$

$$= 8 \times 687.5 \times 6 \times 1.25 / \pi d^3$$

$$= 513$$

$$d = 5.06 = 5 \text{ mm (say)}$$

$$D_m = 5X6$$

$$= 30 \text{ mm}$$

To find the no. of turns,

$$K_s = 96$$

$$= Gd / 8C^2n$$

$$G = 85 \times 10^3$$

$$n = (85 \times 10^3 \times 5) / (8 \times 6^3 \times 96)$$

$$= 2.56$$

Total No. of turns with Squared and Ground ends,

$$= 2.56 + 2$$

$$= 4.56$$

$$= 5 \text{ (say)}$$

$$\text{Free length} = 5X5 + 687.5/96 + 4$$

$$= 36.16 \text{ mm}$$

$$\text{Free length/ } D_m = 36.16 / 30$$

$$= 1.2, \text{ so ok}$$

To check whether nine springs can be accommodated.

$$\text{Mean Diameter of the Friction Disc} = (230+200) / 2$$

Space available/ spring =  $\pi \times 215 / 4$

= 168.86 mm

Do of spring =  $D_m + d$

= 30+5

= 35mm, so ok.

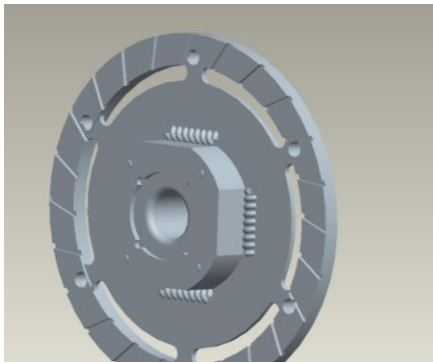
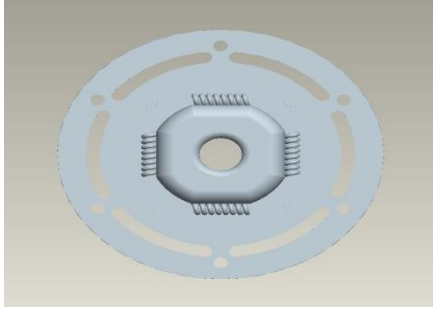

Fig 4. Model of Clutch Plate

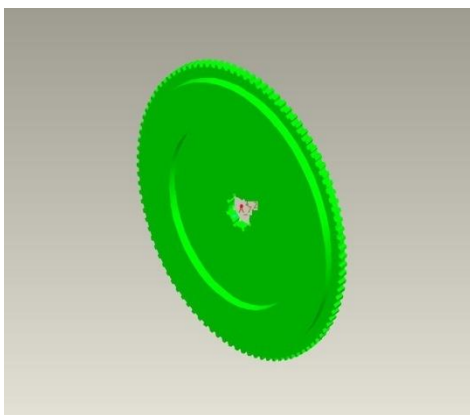

Fig 5. Model of flywheel



Fig 6. Model of pressure plate

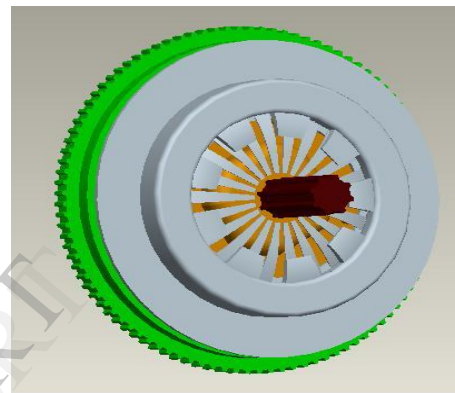

Fig 7. Assembly of clutch

Table 1.Properties of Structural steel

| Name                          | Value   |
|-------------------------------|---|
| Compressive Ultimate Strength | 0.0 Pa  |
| Compressive Yield Strength    | $2.5 \times 10^8$ Pa                            |
| Density                       | $7,850.0 \text{ kg/m}^3$                        |
| Ductility                     | 0.2   |
| Poisson's Ratio               | 0.3   |
| Tensile Yield Strength        | $2.5 \times 10^8$ Pa                            |
| Tensile Ultimate Strength     | $4.6 \times 10^8$ Pa                            |
| Young's Modulus               | $2.0 \times 10^{11}$ Pa                         |
| Thermal Expansion             | $1.2 \times 10^{-5} \text{ 1/}^\circ\text{C}$   |
| Specific Heat                 | $434.0 \text{ J/kg} \cdot ^\circ\text{C}$       |
| Relative Permeability         | 10,000.0  |
| Resistivity                   | $1.7 \times 10^{-7} \text{ Ohm} \cdot \text{m}$ |

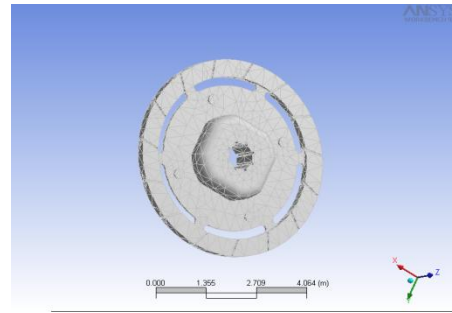

Fig 9.Discretization

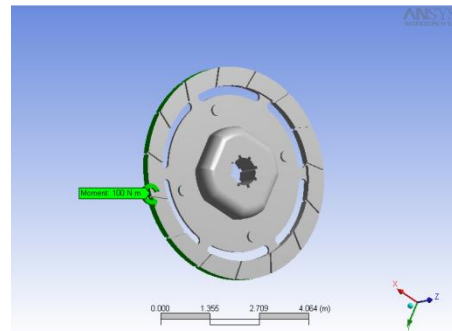

Fig 10. Moment on Plate

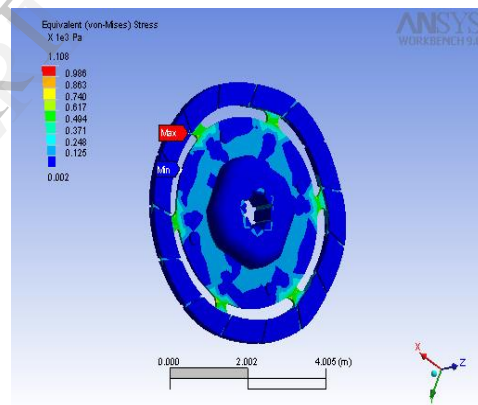

Fig 11. Equivalent Stress

Results in Ansys :

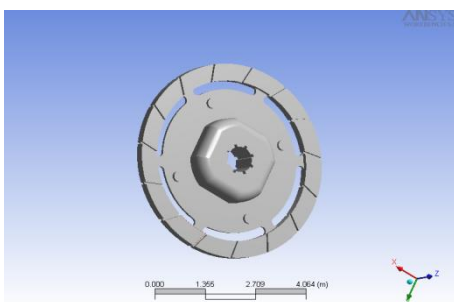

Fig 8.Modelling

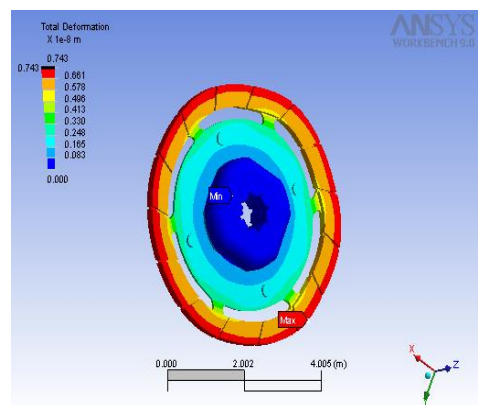

Fig 12.Total Deformation

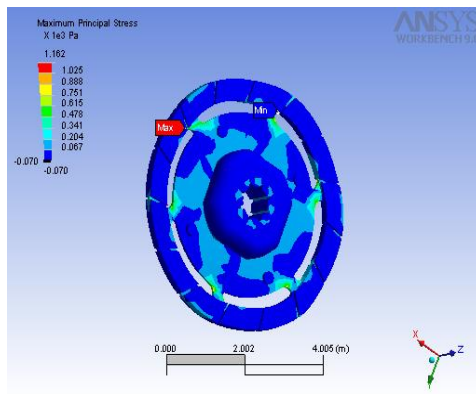

Fig 13.Maximum Principle Stress

## CONCLUSION

After completion of the analysis in CAE software i.e. ANSYS 9.0 based on the values of Equivalent stresses for material loading conditions it is clearly seen that these are less than the allowable stresses for that particular material under applied conditions the part not going to yield and hence the design is safe.

The result occurred are quiet favorable which was expected. The stresses as well as deformation clear the idea about what parameter should have been taken into account while defining the single plate friction clutch.

## REFERENCES

- [1] Crandall S H , *Engineering Analysis*, Mc Graw-Hill, New York,1956.
- [2] Timoshenko S., *Element of Strength of Materials*, Part I and II, Van Nastrand , New Jersey, 1956.
- [3] Timoshenko S. and J.N.Goodier, *Theory of Elasticity*, Mc Graw-Hill, New York,1970.
- [4] Richards, T H, *Energy Methods in Structural Analysis with an Introduction to Finite Element Techniques*, Ellis Harwood Ltd., Chichester,1977.
- [5] Argyris J H and S Kelsey, *Energy Theorom and Structural analysis*, Butlerworth, London, 1960. (Reprinted from Aircraft Engg, 1954-55)
- [6] Zeinkiewicz O C and R L Taylor, *The Finite element method* , vol.I., Basic Formulation and Linear problems, Mc Graw Hill, ( UK ) Limited, 1989.
- [7] Zeinkiewicz O C and K.Morgan, *Finite element and approximation*, John Wiley and Son, Inc., New York.1983.
- [8] Reddy J N , *An Introduction to the finite element Method* , Mc Graw Hill Book Co, Singapore, International student edition,1985.
- [9] Desai C S and J F Wilson, *Numerical method in FEA*, Prentice-Hall of India Private limited, New Delhi, 1978.
- [10] Strang G and B J F ix, *An Analysis of the finite element method*, prentice Hall, Englewood cliffs,N.J,1973.
- [11] Desai C S and J F Abel, *Introduction to the Finite Element method*, Affiliated East-West press pvt. Ltd., New Delhi, East West student Edition, 1977.