

Effect of Soil Structure Interaction on Response of Multistorey Building

Vaishali M. Tormal¹, Dr. K. B. Ladhane¹, Prof. V. R. Rathi¹

¹.Dept. of Civil Engg., P.R.E.C., Loni, University of Pune, Loni (MH), India

Abstract - Earthquakes cause damages to structures and result in great human casualties and economic loss. A fraction of the kinetic energy released from earthquakes is transferred into buildings through soils. The investigation on the mechanism of the energy transferring from soils to buildings during earthquakes is critical for the design of earthquake resistant structures and for upgrading existing structures. In order to understand this phenomena well, a wave-soil-structure interaction analysis is presented. The earthquake wave-soil-structure interaction analysis of tall buildings is the main focus of this research. Three different parametric studies are carried out for buildings subjected to external harmonic loadings and earthquake loadings. In the present study attempt have been made to study the effect of soil structure interaction (SSI) on the performance of building. The results obtained for building considering SSI are compared with building without SSI. Cohesive type of soil has been considered. Three dimensional FEA is carried out using Abaqus software.

I. INTRODUCTION

Structural dynamics deals with methods to determine the stresses and displacements of a structure subjected to dynamic loads. The dimensions of the structure are finite. It is thus rather straightforward to determine a dynamic model with a finite number of degrees of freedom. The corresponding dynamic equations of motion of the discretized structure are then formulated, and highly developed methods for solving them are readily available. In general, however, the structure will interact with the surrounding soil. It is thus not permissible to analyze only the structure. It must also be considered that in many important cases (e.g., earthquake excitation) the loading is applied to the soil region around the structure; this means that the former has to be modelled anyway. The soil is a semi-infinite medium, an unbounded domain. For dynamic loading, this procedure cannot be used. The fictitious boundary would reflect waves originating from the vibrating structure back into the discretized soil region instead of letting them pass through and propagate toward infinity. This need to model the unbounded foundation medium properly distinguishes soil dynamics from structural dynamics.

A specified time-varying load acts on a structure embedded in layered soil. The dynamic response of the structure and, to a lesser extent, of the soil is to be calculated, taking into account the radiation of energy of the waves propagating into the soil region not included in the model.

II. PROBLEM FOR ANALYSIS

A five storied (G+5) space frame resting on a pile foundation is considered for the parametric study. The frame is 18m high with 4×2 bay of each bay is of 5m×5m in plan. The height of each storey is 3m. The slab is 200mm thick, is provided at top as well as at the floor level. The slab at the top is supported by beam 300mm wide and 400mm deep which rest on the column of size 300mm×580mm. While dead load is considered according to unit weight of materials of which the structural component of the frame are made up for the parametric study.

III. MODELING OF THE SUPER AND SUB-STRUCTURES

The elements of the superstructure (beam, column and slab) and that of the substructure (pile and soil) are modeled using simplified modeling approach. The slab in the frame is idealized as the two-dimensional plate element and beams and columns of the frame along with the pile are idealized as one dimensional beam element. The soil is modeled as the discrete independent linear springs.

MODELLING IN ABAQUS

Preprocessing-

It comprises all the steps to create the model with Abaqus/CAE. The following principal steps are taken sequentially:

1. Creating a part /defining the model geometry
2. Defining the material and section properties
3. Creating an assembly
4. Configuring the analysis
5. Assigning interaction properties
6. Applying boundary conditions and applied loads
7. Designing the mesh
8. Creating, running, and monitoring a job

Postprocessing-

The Visualization module provides graphical display of finite element models and results. It obtains model and result information from the output database; it is controlled what information is written to the output database by modifying output requests in the Step module.

Table 1. Material Properties.

Properties	Corresponding Values
Grade of Concrete used for the Frame Elements	M20 (Char. Comp Strength: 20 MPa)
Young's Modulus of Elasticity for Frame Elements	0.25491×10^8 kPa
Grade of Concrete used for the Pile Elements	M40 (Char. Comp Strength: 40 MPa)
Young's Modulus of Elasticity for Pile Elements	0.3605×10^8 kPa
Poisson's Ratio for M20 and M40	0.15
Young's Modulus of Elasticity for soil Elements	4.892966×10^6 kPa
Poisson's Ratio for soil	0.15

In assembly module instances are created for individual parts already created and such instances can be increased in numbers also can be positioned as required. Also some instances can be joined to each other.

Instances are created for Beam, Frame, Slab and Pile. Instances numbers are created by using linear part option. Angle of instances are changed by Rotate Instance option and position is shifted by using Translate Instances. Every part is positioned as required for structure. After proper positioning all Instances are joined using Merge/Cut Instances. After Merge/Cut Instances ABAQUS creates Final Building. This building is required to give Stringers for each part. After applying Stringers Building gets completed.

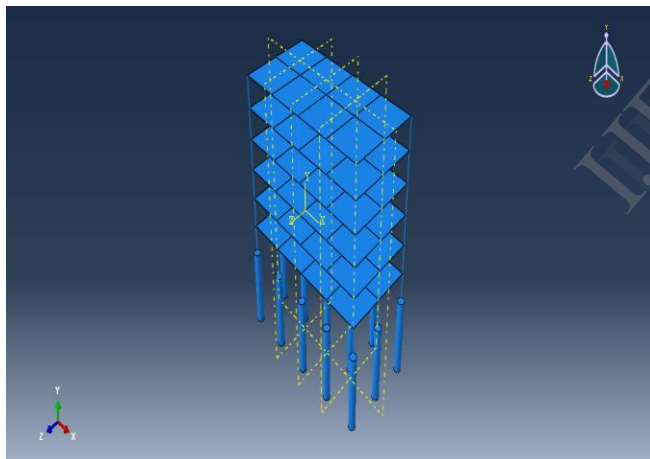

Figure 3.1 Building Without Soil

Instance for soil is created. Soil Instance is positioned in Assembly.

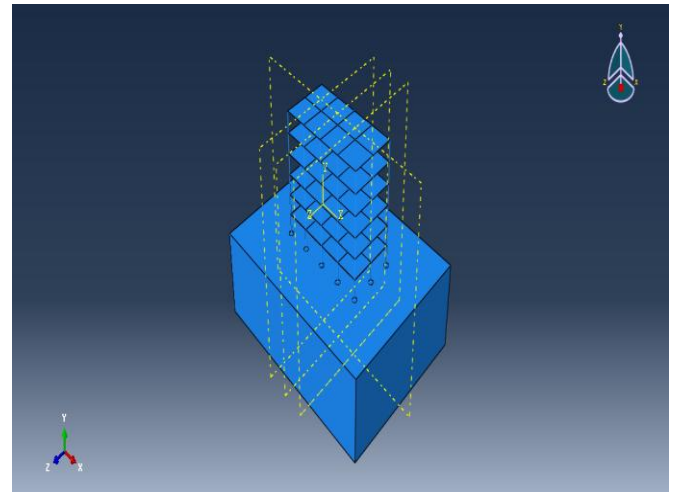

Figure 3.2 Building With Soil

IV. RESULTS

In this section comparison of different parameters of seismic soil structure interaction for a G+5 multi-storeyed frame without soil and frame with soil is done. And analysis validation for frame is done by using substitute frame method.

4.1 Results discussion for multi-storeyed frame

For comparison purpose after analysis three different points are considered from building for both cases.

- Top element of outer column
- Middle element of outer column
- Bottom element of outer column

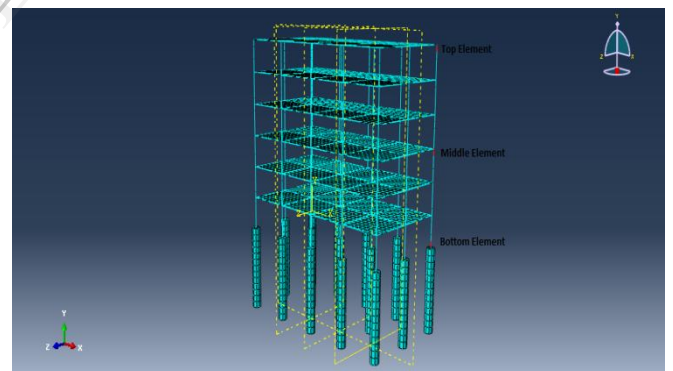

Figure 4.1 Reference Elements selected for Building Without Soil

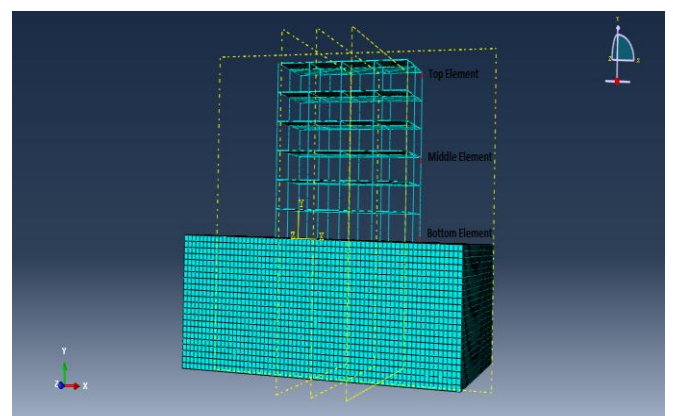

Figure 4.2 Reference Elements selected for Building With Soil

Following figures shows Stresses developed at top element of column against time for multi-storey frame without soil and multi-storey frame with soil,

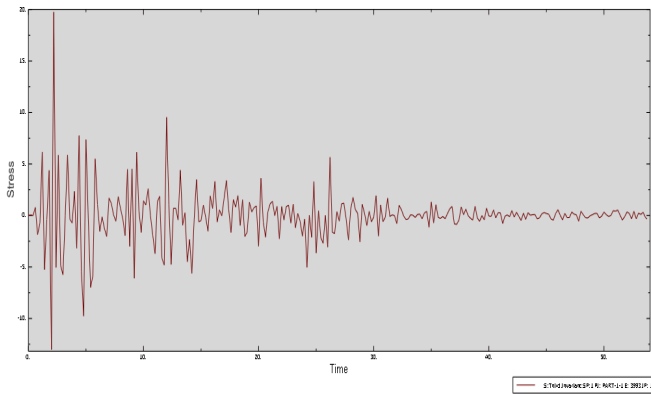

Figure 4.3 Graph of Stress Vs Time of Top Element for Building Without Soil

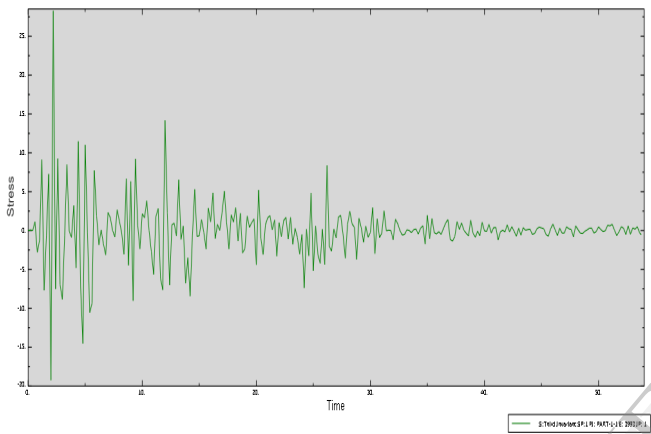

Figure 4.4 Graph of Stress Vs Time of Top Element for Building With Soil

Following figures shows Stresses developed at middle element of column against time for multi-storey frame without soil and multi-storey frame with soil,

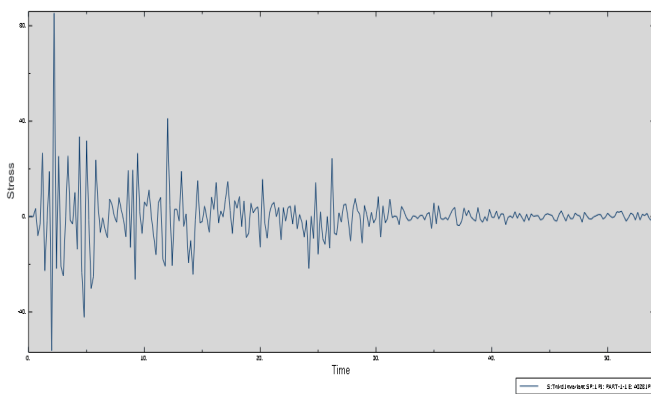

Figure 4.5 Graph of Stress Vs Time of Middle Element for Building Without Soil

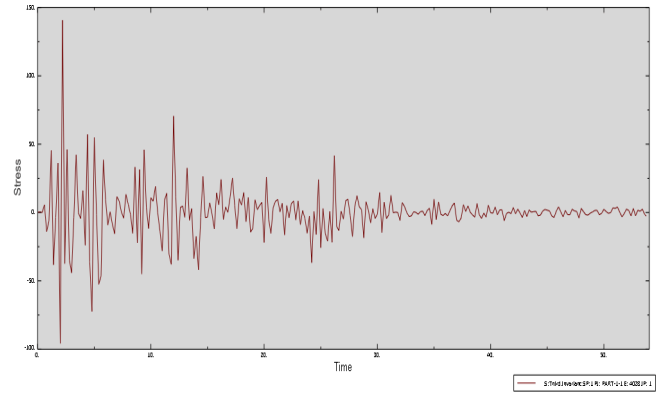

Figure 4.6 Graph of Stress Vs Time of Middle Element for Building With Soil

Following figures shows Stresses developed at bottom element of column against time for multi-storey frame without soil and multi-storey frame with soil,

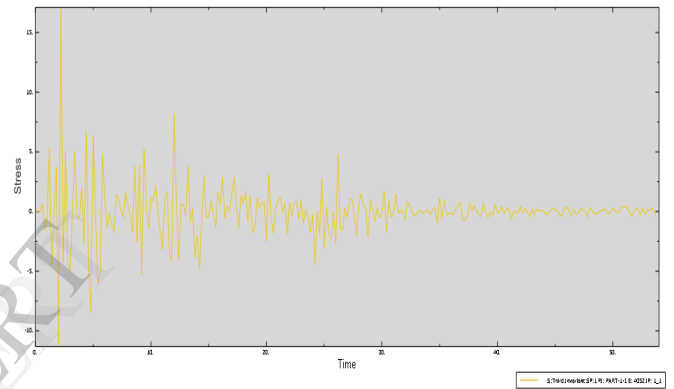

Figure 4.7 Graph of Stress Vs Time of Bottom Element for Building Without Soil

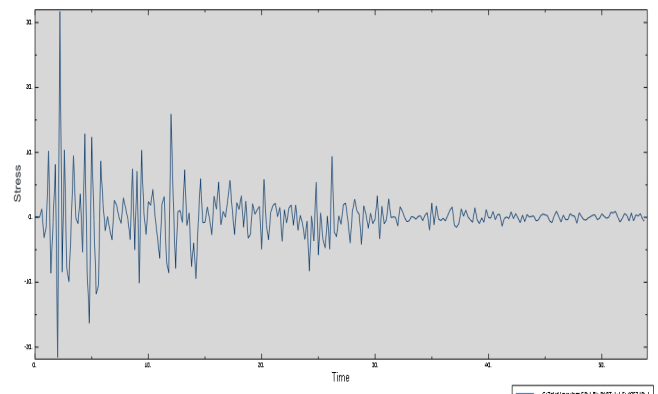

Figure 4.8 Graph of Stress Vs Time of Bottom Element for Building With Soil

Table 4.1 Stress Comparison

Element	Maximum Stress on Building without soil	Maximum Stress on Building with soil
Top Element	20 N/m ²	29 N/m ²
Middle Element	86 N/m ²	140 N/m ²
Bottom Element	17 N/m ²	32 N/m ²

After observing and comparing all graphs it is observed that trend of stress with respect to time in all cases i.e. for top, middle, bottom elements and for both building with soil and building without soil are same. Whereas Stresses developed are different in all cases. Stress developed in middle element is much higher than top and bottom element. Also Stress developed in Building without soil is less than stress developed in Building with soil for all three elements.

Following figures shows Strains developed at top element of column against time for multi-storey frame without soil and multi-storey frame with soil,

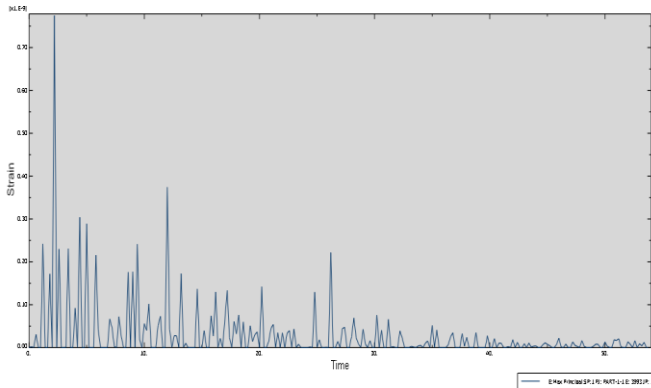

Figure 4.9 Graph of Strain Vs Time of Top Element for Building Without Soil

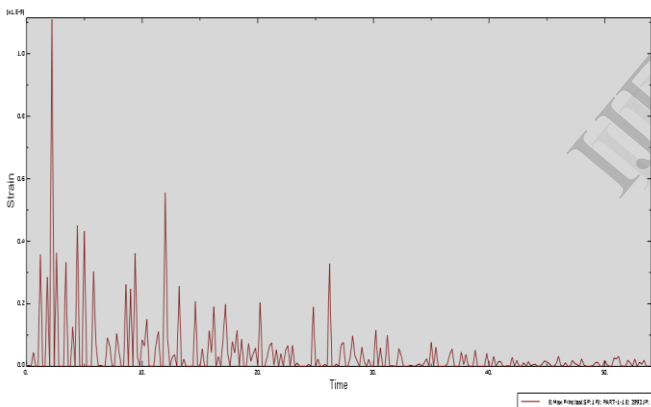

Figure 4.10 Graph of Strain Vs Time of Top Element for Building With Soil

Following figures shows Strains developed at middle element of column against time for multi-storey frame without soil and multi-storey frame with soil,

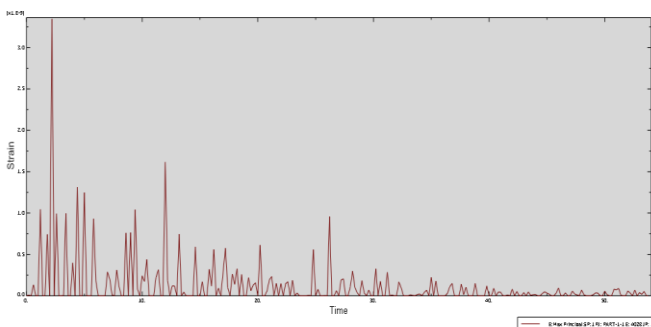

Figure 4.11 Graph of Strain Vs Time of Middle Element for Building Without Soil

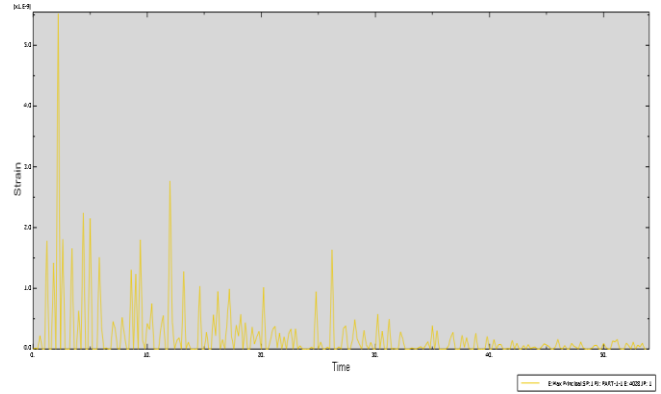

Figure 4.12 Graph of Strain Vs Time of Middle Element for Building With Soil

Following figures shows Strains developed at bottom element of column against time for multi-storey frame without soil and multi-storey frame with soil,

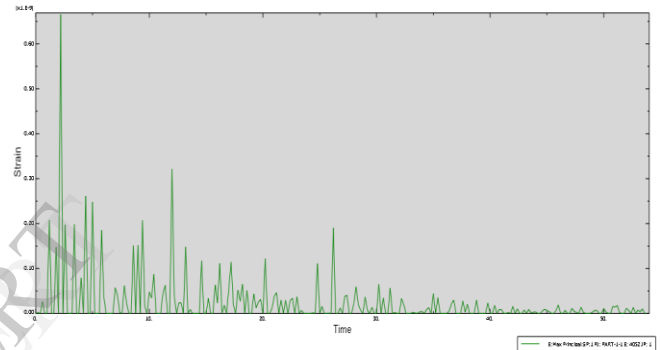

Figure 4.13 Graph of Strain Vs Time of Bottom Element for Building Without Soil

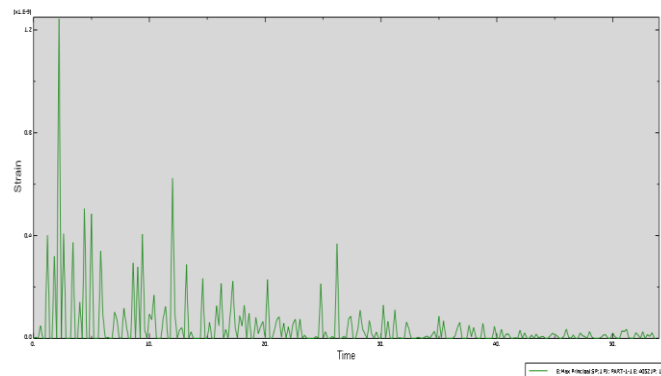

Figure 4.14 Graph of Strain Vs Time of Bottom Element for Building With Soil

Table 4.2 Strain Comparison

Element	Maximum Strain on Building without soil	Maximum Strain on Building with soil
Top Element	0.78	1.12
Middle Element	3.38	5.7
Bottom Element	0.66	1.26

While comparing all graphs it can be seen that strain developed, in both cases i.e. both building with soil and

building without soil, is getting increased from bottom element and again decreasing towards top element. Though the trend of strain with respect to time in all cases i.e. for top, middle, bottom elements and for both building with soil and building without soil are same, strain developed in Building without soil is less than strain developed in Building with soil for all three elements.

Following figures shows Accelerations developed against time for multi-storey frame without soil and multi-storey frame with soil,

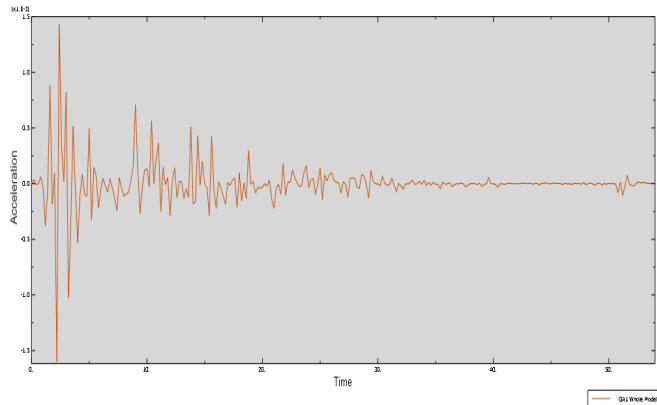

Figure 4.15 Graph of Acceleration Vs Time of whole model for Building Without Soil

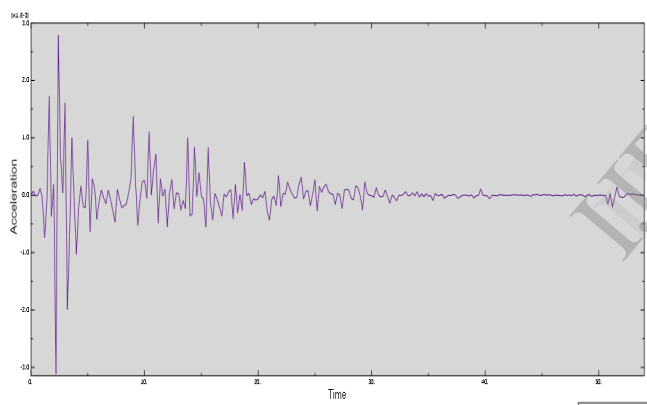

Figure 4.16 Graph of Acceleration Vs Time of whole model for Building With Soil

Table 4.3 Acceleration Comparison

Element	Maximum Acceleration with Building without soil	Maximum Acceleration with Building with soil
Whole model	-1.56 m/s ²	-3.13 m/s ²

Above table shows maximum acceleration developed in building in both cases of with soil and without soil. It shows that acceleration developed in building with soil is nearly double than acceleration developed in building without soil. It can also be seen from graph that trend does not get any impact of soil.

Following figures shows Displacements developed against time for multi-storey frame without soil and multi-storey frame with soil,

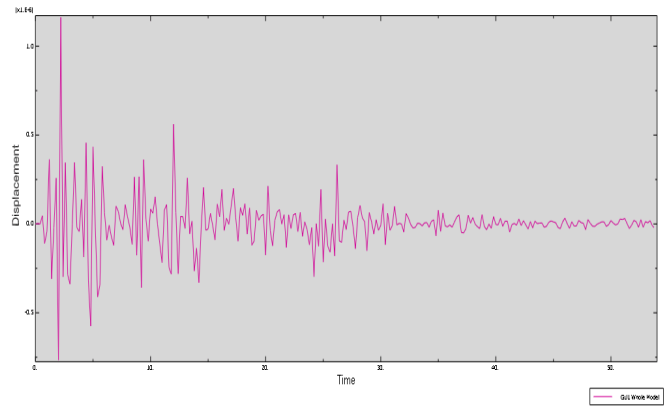

Figure 4.17 Graph of Displacement Vs Time of whole model for Building Without Soil

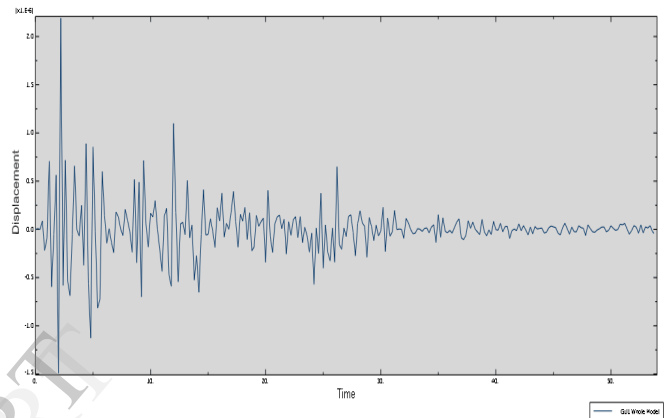

Figure 4.18 Graph of Displacement Vs Time of whole model for Building With Soil

Table 4.4 Displacement Comparison

Element	Maximum Displacement with Building without soil	Maximum Displacement with Building with soil
Whole model	-1.56 m	-3.13 m

From displacement graphs, more displacement is observed in case of building with soil compare to displacement in building without soil. Trend of both graphs i.e. for building with soil and building without soil are same, whereas nearly half displacement is observed in building without soil than building with soil.

Following figures shows deflection at 53.74seconds for multi-storey frame without soil and multi-storey frame with soil,

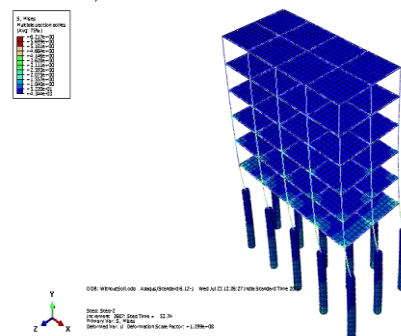

Figure 4.19 Deformed Building at 53.74 seconds for Building Without Soil

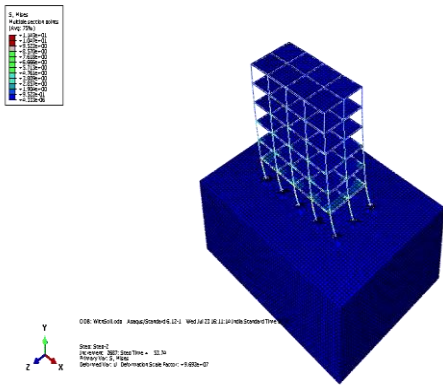

Figure 4.20 Deformed Building at 53.74 seconds for Building With Soil

Following figures shows Accelerations developed against time for multi-storey frame without soil and multi-storey frame with soil and reference Elcentro earthquake acceleration against time graph

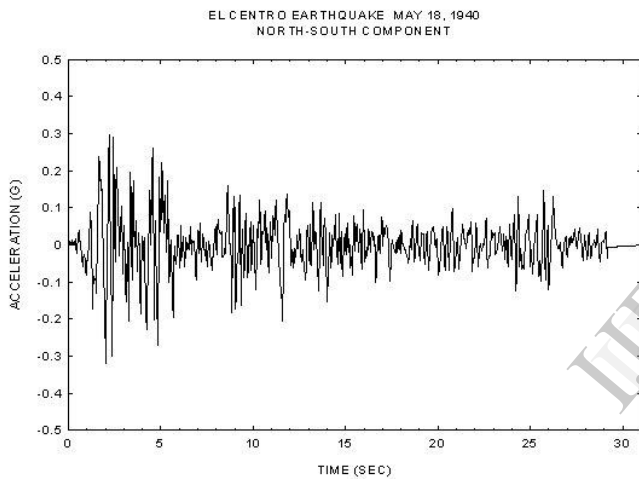

Figure 4.21 Graph of Acceleration Vs Time of Elcentro Earthquake

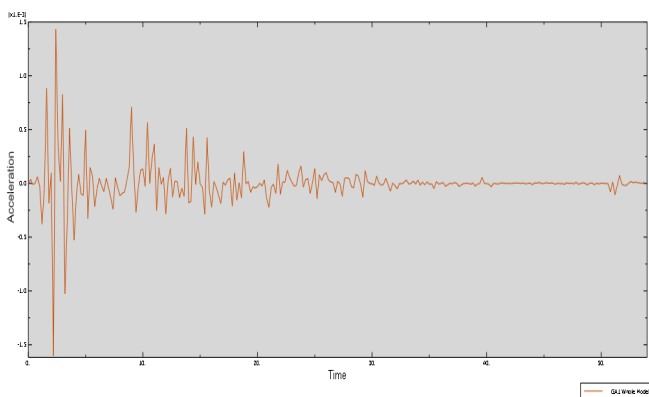

Figure 4.22 Graph of Acceleration Vs Time for Building Without Soil

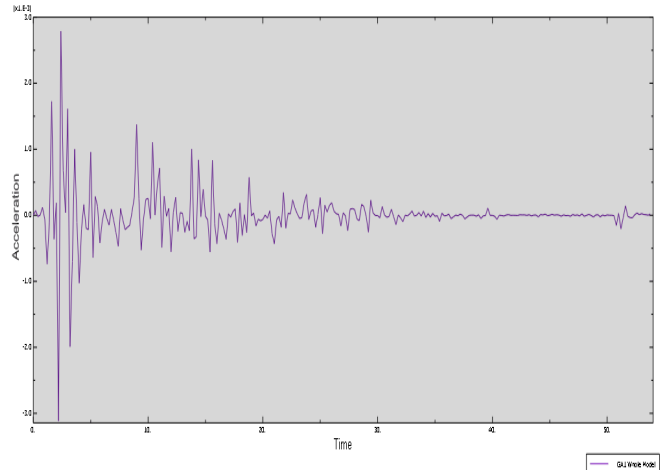

Figure 4.23 Graph of Acceleration Vs Time for Building With Soil

Table 4.5 Comparison with reference data

Element	Maximum Acceleration on Building without soil	Maximum Acceleration on Building with soil	Maximum Acceleration at Elcentro
Whole model	-1.56 m/s ²	-3.13 m/s ²	-3.15 m/s ²

After comparing Elcentro accelogram with the accelogram of with and without soil it is seen that it is nearly equal to the accelogram of building with soil.

V. CONCLUSIONS

From the present study it has been observed that, there is considerable difference in response with multi-storey building considering effect of SSI.

- In case of building with SSI is more conservative. It develops more displacement, amplitude, stresses and strain than the case of building without soil.
- The case of building with mass soil is more conservative than the case of building without the soil.
- The SSI is highly nonlinear. The increase in superstructure or pile stiffness does not necessarily reduce the seismic response of SSI system
- SSI effect increases displacement in each storey of frame.
- It is concluded that in seismic response analysis of SSI system, it is important to take into account of material nonlinearity of the soil and geometrical nonlinearity at the interface of the structure and the soil.
- Considering the overall soil behaviour it is seen the soil beneath the structure and near the fixed boundaries is comparatively stable.
- After comparing Elcentro Accelogram with the accelogram of with and without soil it is seen that it is nearly equal to the accelogram of building with soil.

➤ FUTURE SCOPE OF STUDY

- In what situation SSI effects are beneficial or detrimental?
- How should analytical model and computer program that are being developed for SSI analysis be validated and made accessible to the practitioner.
- Present study we can carry out by changing different layers of soil.
- What is an appropriate analysis procedure to account for SSI interaction for various types of pile foundation (small pile verses large diameter pile)?

REFERENCES

- [1] John p. Wolf, "*Dynamic Soil-Structure Interaction*", Electrowatt Engineering Services Ltd.
- [2] Sanaz Mahmoudpour, Reza Attarnejad, and Cambyse Behnia, "*Dynamic Analysis of Partially Embedded Structures Considering Soil-Structure Interaction in Time Domain*", Hindawi Publishing Corporation Mathematical Problems in Engineering Volume 2011, Article ID 534968.
- [3] Wen s. Tseng, "*seismic instrumentation for soil-structure interaction assessment*", International Civil Engineering Consultants, Inc.
- [4] Alexander Tyapin, "Soil-Structure Interaction", chapter 6 from book Earthquake Engineering.
- [5] Choon-Gyo Seo, Chung-Bang Yun, Jae-Min Kim, C.-G. Seo "*Three-dimensional frequency-dependent infinite elements for soil-structure interaction*", et al. / Engineering Structures 29 (2007).
- [6] Lin Jiahao, Gao Qiang, Zhong Wanxie, W.P. Howson, F.W. Williams, "*Isotropic layered soil-structure interaction caused by stationary random excitations*",
- [7] J. L. Wegner, M. M. Yao and S. K. Bhullar, "*Dynamic wave soil structure interaction analysis of a two way asymmetric building system DSSIA-3D*", Journal of Engineering and Technology Research Vol.1 (2), pp.026-038, May 2009.
- [8] Professor T.D. O'Rourke, "*Soil-Structure Interaction under Extreme Loading Conditions*", the Thirteenth Spencer J. Buchanan Lecture.
- [9] Lou Menglin and Wu Jingning, "*effects of soil-structure interaction on structural Vibration control*", Developments in Geotechnical Engineering.
- [10] Farhang Ostadan, Nan Deng, Orhan Gurbuz and Sanjeev Malushte, "*seismic soil-structure interaction analysis including ground motion incoherency effects*", The 14th World Conference on Earthquake Engineering October 12-17, 2008.
- [11] R. M. Jenifer Priyanka, N. Anand, Dr. S. Justin, "*Studies on Soil Structure Interaction of Multi Storeyed Buildings with Rigid and Flexible Foundation*", International Journal of Emerging Technology and Advanced Engineering.
- [12] H. Zolghadr Jahromi, B.A. Izzuddin and L. Zdravkovic, "*Partitioned analysis of nonlinear soil-structure interaction using iterative coupling*", Interaction and Multiscale Mechanics, Vol. 1, No. 1 (2007) 33.51.