

# Finite Element Analysis and Topology Optimization of Bamboo Bike Frame

Ishfaq Hussain

Department of Advanced Mechanical Engineering  
Coventry University  
Coventry, England, UK

**Abstract** - In response to the global imperative for sustainable solutions, this study investigates the finite element analysis (FEA) and optimization of bamboo as a material for bicycle frames. As eco-friendly transportation gains importance, bicycles are recognized as a key component of sustainable mobility. This research utilizes FEA to thoroughly examine the structural performance of bamboo frames, enabling design optimization to enhance their strength and durability. The objectives include creating a comprehensive 3D FEA model of the bamboo bike frame, simulating various loading scenarios, and using the FEA results for topology optimization. Special emphasis is placed on assessing bamboo's environmental impact in comparison to traditional materials like steel and aluminum. Bamboo's intrinsic properties, such as high tensile strength, lightweight nature, and natural vibration absorption, present it as a compelling alternative for bike frame construction. This study integrates FEA techniques, and topology optimization to establish the viability of bamboo as a material for bicycle frames, highlighting key factors influencing frame design, material properties, and optimization techniques.

**Keywords**— Finite Element Analysis (FEA), Bicycle Frame, Bamboo Material, Topology Optimization, Material Properties

## I. INTRODUCTION

In the face of unprecedented global challenges, sustainable solutions across various life aspects have become imperative. Transportation, a pivotal domain in this endeavour, is increasingly turning towards eco-friendly alternatives to mitigate its environmental footprint. Among these alternatives, bicycles have emerged as a sustainable and environmentally friendly mode of transport. The choice of materials for bicycle frame construction significantly influences their performance, sustainability, and cost-effectiveness. Traditional materials like aluminium, carbon fiber, and steel have long dominated the bicycle industry, but the introduction of sustainable materials such as bamboo has brought about a significant shift [1].

Bamboo bicycles present a promising alternative due to bamboo's inherent properties like high tensile strength, lightweight nature, and natural vibration-damping capabilities. These properties not only make bamboo an environmentally friendly choice but also offer unique riding experiences [1]. Bamboo has emerged as a promising alternative to conventional steel or composite frame bicycles due to its cost-effectiveness, rapid growth rate, and ease of processing. Furthermore, bamboo exhibits favourable attributes such as lightweight properties, impressive stiffness, and remarkable strength of approximately 40 KN/cm<sup>2</sup> compared with steel, which can resist 37KN/cm<sup>2</sup> [2]. Bamboo is an excellent

construction material due to its high bending strength and flexibility. Unlike other building materials, bamboo can grow up to 40 meters tall and withstand strong winds without breaking [3]. Bamboo has an average ultimate tensile strength of 300-350MPa and an average density of 0.4(g/cm<sup>3</sup>). This strength is comparable to that of aluminium, a commonly used material to construct bicycles, which has an ultimate tensile strength of 310 MPa but an average density of 2.7 (g/cm<sup>3</sup>) [4]. The advantage of bamboo bike designs lies in their use of easily accessible and renewable materials, offering an alternative to potentially costlier industrial products. Environmentally, this approach is more sustainable since the materials for the bicycle's production are not mined and processed but are instead harvested and replanted as needed, ensuring a continuous and endless supply of bamboo [5].

The growing interest in sustainable transportation and environmentally friendly materials underscores the significance of this study. Bamboo bike frames contribute to reducing carbon footprints and offer unique riding experiences due to their material characteristics. Despite the potential of bamboo as a sustainable alternative, there is a lack of comprehensive research on its structural performance and optimization for bicycle frames. This gap in knowledge necessitates focused investigation to harness the full potential of bamboo in bicycle manufacturing [6].

This research aims to analyze the structural performance of bamboo as a material for bike frame construction using Finite Element Analysis (FEA) and subsequently optimize the design for enhanced strength, durability, and sustainability. Through detailed FEA modelling, simulation, analysis, and Topology Optimization, this study seeks to provide valuable insights into bamboo's potential as a competitive alternative for bicycle frame construction, addressing the current gaps in standardization and predictability of bamboo as a material for bicycle frames.

## II. METHODOLOGY

### A. 1D Static Analysis of Bike Frame

In the 1D static analysis, the bike frame was simplified into a one-dimensional model, focusing on key structural elements such as tubes and joints. This analysis was done in HyperMesh, and it was essential for understanding the behaviour of these elements under static loads, which are consistent and unchanging over time.

1) *Modelling*

The core structure of a bike is its frame, which consists of essential parts like the top tube, seat tube, head tube, chain stay, and seat stay. These components serve as the foundation to which the wheels and other bike parts are attached. The design of this bike frame has been tailored for individuals with a height ranging from 5 feet to 5 feet 11 inches, and the design parameters are shown in the table (1).

Table I: Design parameter of bicycle frame

Parameter	Value
Top Tube	585 mm
Seat Tube	508 mm
Head Tube	104 mm
Chain Stay	450 mm
Seat Stay	590 mm
Seat Tube angle	73°

2) *Assumptions*

- Bamboo material is considered homogeneous throughout the frame.
- Variation in properties within the material are neglected for simplicity.
- Bamboo is treated as an isotropic material.
- Consistent mechanical properties are assumed in all direction.
- Bamboo exhibits linear elastic behaviour under various loading conditions.
- The analysis focuses on static loading scenarios.
- Dynamic effects or dynamic loading conditions are disregarded.
- A consistent environmental context is assumed during the analysis, such as temperature and humidity.

3) *Material Selection and Properties*

The primary focus is on the finite element analysis (FEA) of bike frames using HyperMesh for steel, aluminium, and bamboo to evaluate their mechanical performance. The research aims to provide a comprehensive understanding of how bamboo, as a sustainable material, compares to traditional bike frame materials. In HyperMesh, the properties of each material are utilized to create precise models of bike frames constructed from Bamboo, steel, and aluminium. This software facilitates simulations under static loading conditions to evaluate how each material influences the overall performance and durability of the bike frame.

Table II: Mechanical properties of materials selected

Materials	Modulus of elasticity (Mpa)	Poisson's ratio	Density (kg/m <sup>3</sup> )
Bamboo	16170	0.3	600
Aluminum	72000	0.33	2700
Steel	205000	0.29	7800

4) *Boundary Conditions*

In the analysis of the bike frame, specific boundary conditions have been established to simulate realistic structural responses. The rear drop-outs and front head tube have been fixed to emulate the secure attachment of these components, reflecting real-world structural stability as shown in fig (1). The fixed constraints prevent translational movement at these critical points, ensuring an accurate representation of the frame's behaviour under various loads. These boundary conditions are crucial for a comprehensive finite element analysis, contributing to the assessment and optimization of the bike frame's strength and durability

5) *Loading Conditions*

Numerous studies have explored the analysis of bicycle frames using Finite Element Analysis (FEA) under various loading conditions. The investigation involved simulating recumbent and Schwinn upright bicycle frames, exposing them to different scenarios like vertical loads on the steering tube, vertical load at the center of the bottom bracket, vertical load on the seat [7]. Additionally, the simulations covered static situations, steady pedalling on different pavements, and hard acceleration on level ground and uphill. The research considers six loading conditions: static start-up, steady pedaling, standing up on bikes, vertical loading, horizontal loading, and rear wheel braking.

**1<sup>st</sup> Condition: Static start-up**

In this condition, we consider the bicycle to be at rest, and there's a rider on the saddle with a weight of 700 N (equivalent to 71.3 kg). We account for the gravitational force, which is 9.81 m/s<sup>2</sup>. It's important to note that this analysis doesn't take into consideration the impact of air resistance.

**2<sup>nd</sup> Condition: Steady-state pedalling**

In this scenario, imagine a person riding a bicycle, weighing about 700N. They're pedaling steadily while applying a constant force of 200N to the pedal attached to the bike's bottom bracket.

**3<sup>rd</sup> Condition: Standing up on the bikes**

In cases where the rider stands up on the bike, forces of 300 N and 200 N are applied to the pedal and front head tube, respectively.

**4<sup>th</sup> Condition: Vertical loading:**

This condition represents a vertical force equivalent to twice the weight of the driver, influenced by the G factor. The G factor is utilized as a simplification for the vibration effects of biking on uneven roads, holes, and rough terrain. The simulation introduces the "G factor" to account for the impact on the bicycle frame when encountering a deep road hole, assuming total energy transfer to the structure and it can be seen in Fig (1).

**5<sup>th</sup> Condition: Horizontal loading:**

A force of 980 N is applied horizontally to the front head tube of the bicycle, simulating conditions where the rear drop-out remains stationary. In the bicycle manufacturing industry,

compliance with standards set by the Bureau of National Affairs (BNA) in 1976 and the Consumer Product Safety Commission is crucial [8]. Every bicycle design undergoes various physical tests to meet these standards. An example scenario is akin to a low-speed bicycle hitting a wall. During such tests, it is essential for the bike to withstand the force without developing significant cracks or deformations in order to pass the examination.

**6<sup>th</sup> Condition: Rear wheel breaking:**

In this scenario, we assume a gradual application of hindrance specifically at the wheels, causing all loads to be concentrated only on the rear wheels. The load, equivalent to 200 N, is applied to the rear drop-outs, representing the braking force. This condition simulates a decrease in speed and is integrated into our analysis. The process involves the driver pedaling the bike until it reaches a steady speed and then applying brakes until the bike comes to a complete stop, as illustrated in Fig (1).

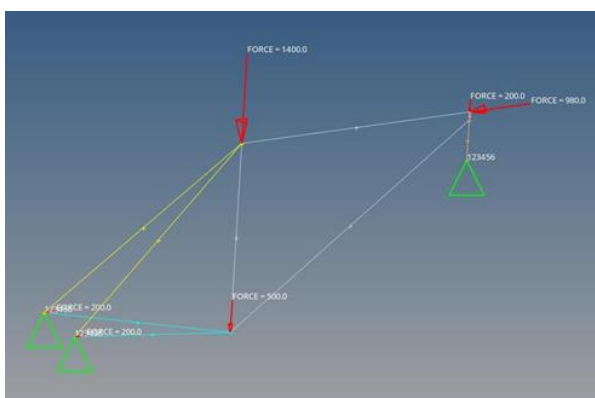

Fig. 1. Loading and boundary conditions

**B. Mesh Convergence Study**

In the finite element analysis (FEA) of the bamboo bike frame, the meshing process is a critical step [9]. The quality and size of these elements significantly influence the accuracy of the FEA results. For bamboo, precise meshing is crucial to capture its behavior accurately under load [10].

*1) Conducting Mesh Convergence Tests to Ensure Accuracy*

Mesh convergence tests were conducted to determine the optimal mesh size that balances computational efficiency with result accuracy. This process involved systematically changing the element size and observing the impact on key output parameters, such as Von Mises stress and displacement. The goal was to identify a mesh size where further refinement does not significantly alter the results, indicating that the solution has converged.

*2) Selection of Optimal Mesh Size Based on Convergence Results*

The following tables and graphs show the mesh convergence test results for the bamboo bike frame.

Table III: Element size vs von mises stress and displacement

Element Size (mm)	Von Mises Stress (Mpa)	Displacement (mm)
32	36.7	0.19
31	42.1	0.27
30	48.3	0.42
28	52.2	0.50
26	58.9	0.54
24	64.5	0.63
22	69	0.71
20	78.1	0.781
18	87.6	0.78
16	87.86	0.78
14	87.9	0.719

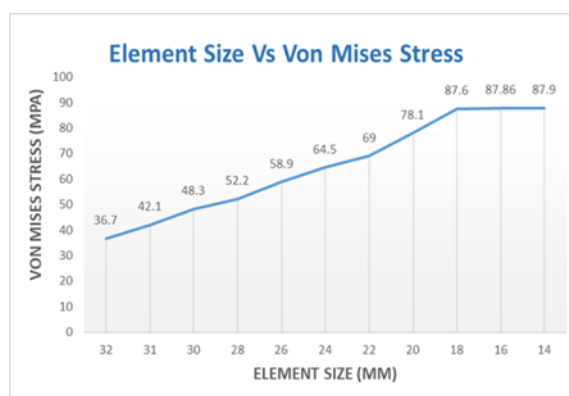

Fig. 2. Graph between element size and von mises stress

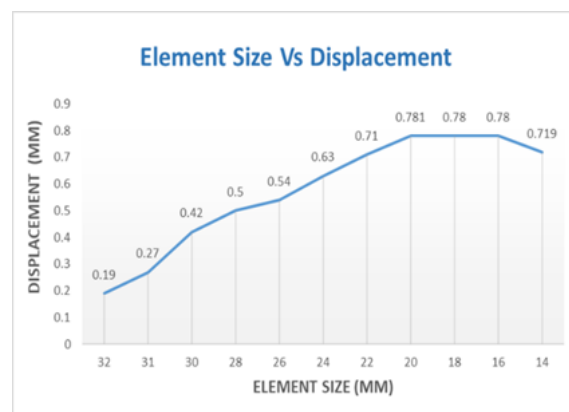

Fig. 3. Graph between element size and displacement

Based on these results, a 16mm element size was selected as optimal. This decision was made considering the balance between computational efficiency and the accuracy of stress and displacement results. At 16mm, the Von Mises stress and displacement values showed sufficient stability, indicating that further refinement of the mesh would not significantly alter the results. This mesh size effectively captures the mechanical behavior of the bamboo material under static loading conditions, as required for the accurate simulation of the bike frame's performance.

C. 3D Static Analysis of Bamboo Bike Frame

The 3D static analysis begins with the detailed modelling of the bamboo bike frame. While the model does not replicate an exact bike frame, it closely represents the Design space of a typical bamboo frame. This model incorporates the unique characteristics of bamboo as a material. The 3D model is created using SolidWorks and it includes all critical components such as joints, and connections, ensuring a comprehensive representation of the frame's physical and mechanical properties.

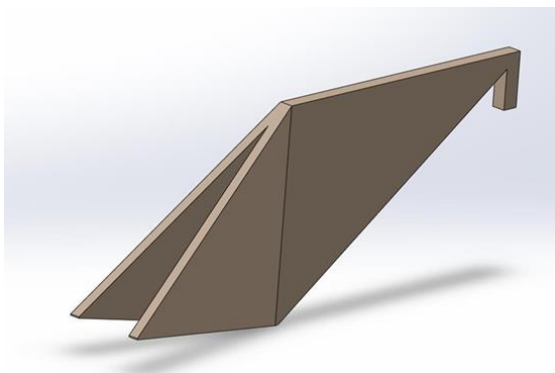

Fig. 4. Design space for bamboo bike frame

1) Material Properties

Material – Bamboo with Modulus of elasticity value 16170MPa, Poisson’s ratio 0.3, and Density 600kg/m3 which is equal to  $0.6 \times 10^{-9}$  ton/mm<sup>3</sup>. As we used HyperMesh for this analysis so we have mentioned the value of density in ton/mm<sup>3</sup> and all other dimensions in millimeter (mm) such as length, diameter, and thickness.

2) Meshing

The meshing used in this research is 3D mesh with tetrahedral elements types and the element size is 16mm as shown in Fig (5). This mesh size was strategically chosen to ensure a balance between computational efficiency and the accuracy of the simulation results. Tetrahedral elements, known for their flexibility in modelling complex geometries [11]. This element type is particularly suitable for capturing the intricate details of the bamboo bike frame.

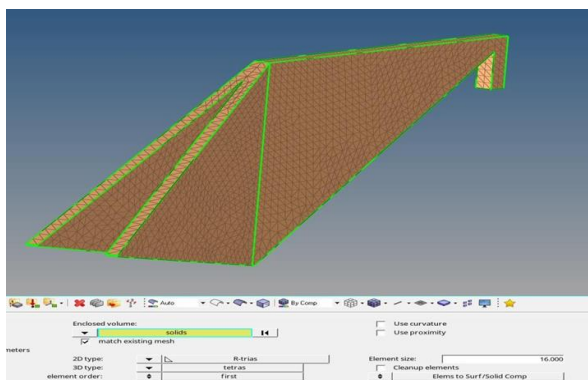

Fig. 5. Meshing of bamboo frame

3) Static Load and Boundary Conditions

Static loads are applied to the 3D model to simulate real-world conditions. These loads include the weight of the rider, gravitational forces, and any additional static forces that a bike frame might encounter during typical use. In this analysis, we provide different loading condition scenarios: static start up, steady pedaling, standing up on bikes, vertical loading, horizontal loading, and rear wheel braking.

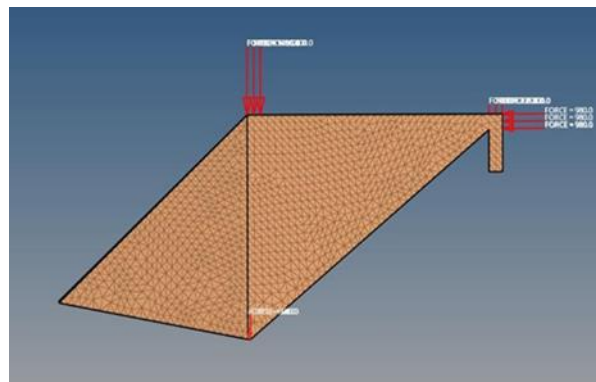

Fig. 6. Loading conditions

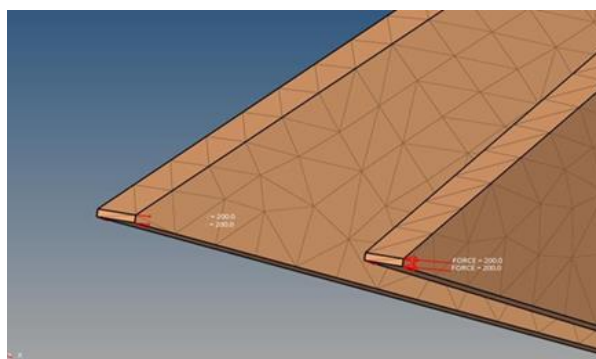

Fig. 7. Loading conditions

Boundary conditions are set to replicate real-world constraints, such as fixed joints or points of contact with other parts of the bike. This step is crucial for accurately simulating how the frame will perform under load, taking into account the unique properties of bamboo. In this study, constraints were placed below the front head tube and in the rear dropout of the bike frame models, restricting both translational and rotational movements as shown in Fig (8) (9).

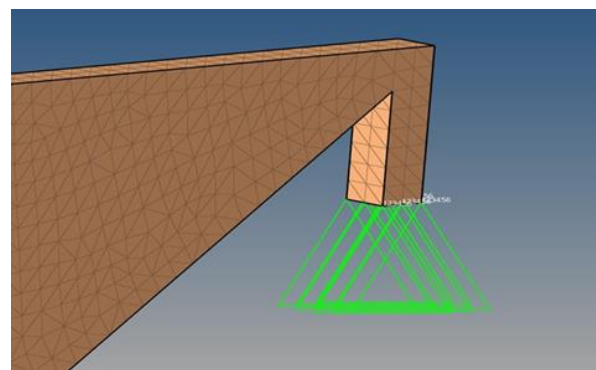

Fig. 8. Boundary condition 1



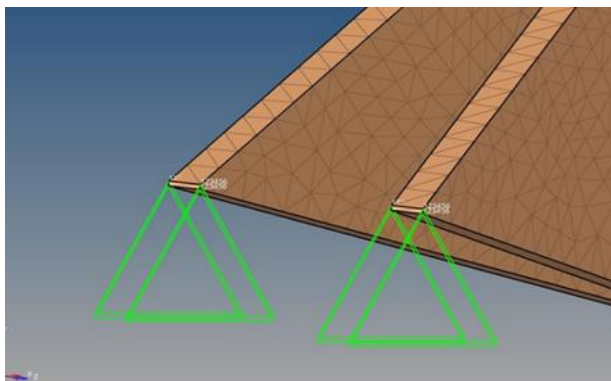

Fig. 9. Boundary condition 2

**D. Topology Optimization**

Optimization methods will play a critical role in enhancing the frame's performance. The optimization process will likely involve the use of algorithms such as topology optimization techniques. This algorithms will iteratively adjust the design parameters of the bamboo frame, such as geometry and material distribution, based on FEA results and specific performance criteria. The goal will be to achieve an optimal design that maximizes structural integrity, minimizes weight, and ensures the frame meets the desired mechanical specifications.

In the topology optimization process for the bamboo bike frame, the following steps were methodically executed:

**1) Design Variable/Space Establishment**

The optimization commenced with the creation of a finite element model representing the bamboo bike frame structure, which defined the design space. The model was processed and prepared for optimization using HyperMesh, a pre-processing tool. Within HyperMesh, the optimization feature in the analysis toolbar was accessed to establish the design parameters for the bamboo bike frame. This step included updating parameters and pattern grouping to align with the specific optimization objectives.

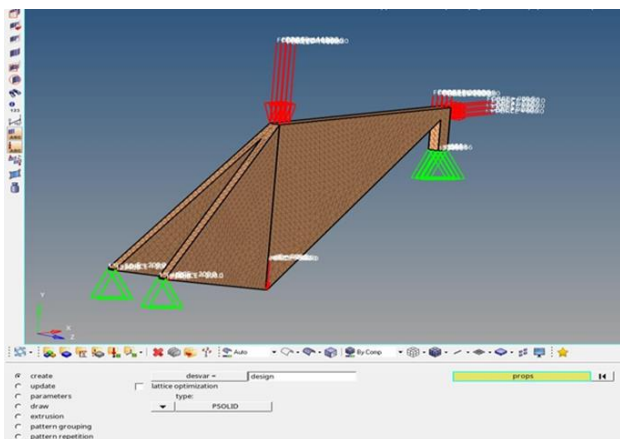

Fig. 10. Establish design parameters

**2) Setting Responses such as Volume Fraction and Weight**

Key responses, including the volume fraction and weight of the frame, were identified and set as targets for the optimization process. These responses served as critical indicators of the optimization's effectiveness, guiding the algorithm in material distribution and structural refinement.

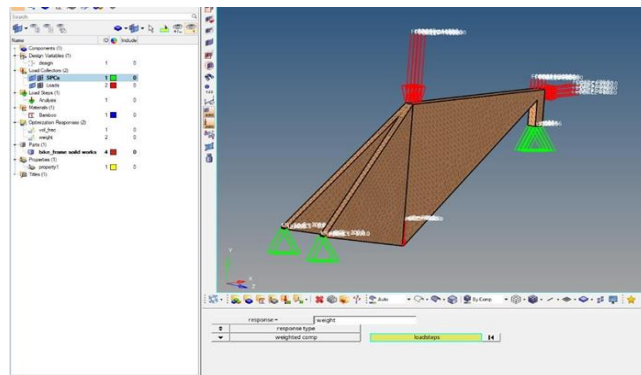

Fig. 11. Setting responses for topology optimization

**3) Constraints Implementation (Limiting Value Fraction)**

A crucial aspect of the optimization was the implementation of constraints, particularly concerning the volume fraction. An upper bound value of 0.3 was set as shown in fig (12), indicating that the solver should retain a minimum of 30% of the original volume in the optimization process. This constraint was essential to prevent the solver from utilizing an excessive volume, potentially reaching 100%. The establishment of this upper bound ensured a balanced approach to material reduction and structural integrity.

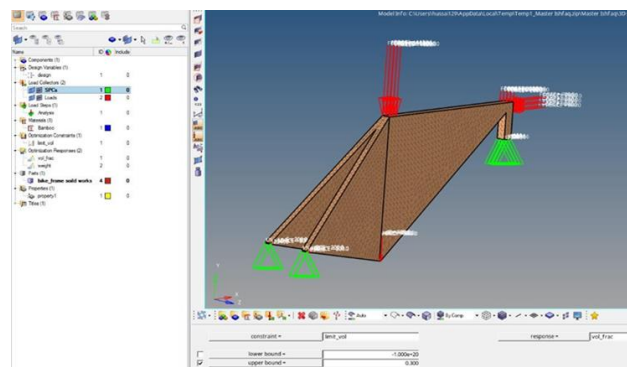

Fig. 12. Constraint implementation for topology optimization

**4) Setting Optimization Control Panel**

The optimization control panel is employed to define key control parameters, specifically setting the values of discreteness and checkerboard to 2 and 1, respectively as shown in fig (13). The choice of a discreteness value of 2 significantly influences the tendency of solid elements in topology optimization to converge towards dominant structures, incorporating member size control while adhering to manufacturing constraints. This strategic configuration

plays a vital role in guiding the optimization process, ensuring effective and controlled convergence to desired outcomes in the bamboo bike frame analysis.

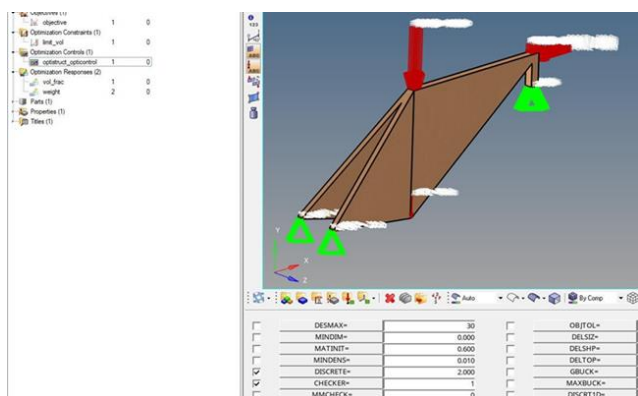

Fig. 13. Setting opticontrol panel for optimization

### 5) Objective Setting

The objectives for the topology optimization of the bamboo bike frame included weight reduction and strength maximization. Weight reduction was targeted to enhance the bike's efficiency and maneuverability, while strength maximization was crucial for ensuring the safety and durability of the frame. These objectives were carefully balanced to achieve an optimal design that does not compromise on either aspect.

Finally, the optimization was executed using OptiStruct, a process that involved a systematic approach to refine the bamboo bike frame's design in alignment with the set objectives and constraints.

## III. RESULTS

### A. 1D Results

In the 1D static analysis of the bike frame, three different materials, namely Bamboo, Aluminum, and Steel, were subjected to analysis using HyperMesh. The obtained results, as presented in the table below, showcase the displacement and Von Mises stresses for each material.

Table IV: 1D analysis results for different frame materials

Materials	Displacement (mm)	Von Mises Stresses (Mpa)
Bamboo	0.1371	1.099
Aluminum	0.0307	1.098
Steel	0.0108	1.099

The 1D static analysis revealed that the Bamboo bike frame exhibited a displacement of 0.1371 mm and Von Mises stresses of 1.099 MPa. The figure (14) and figure (15) visually represent the stress distribution and deformation patterns in the Bamboo frame. The larger displacement suggests more flexibility in the Bamboo frame compared to Aluminum and Steel.

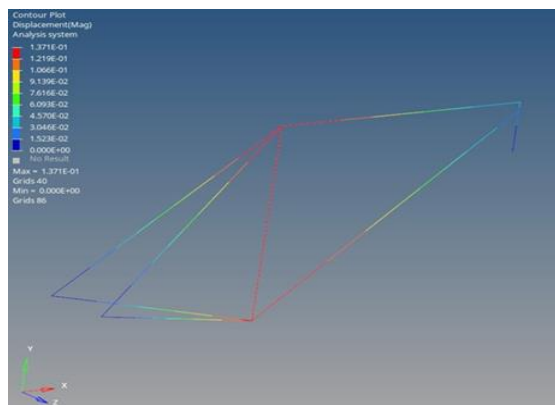

Fig. 14. Total displacement of bamboo bike frame

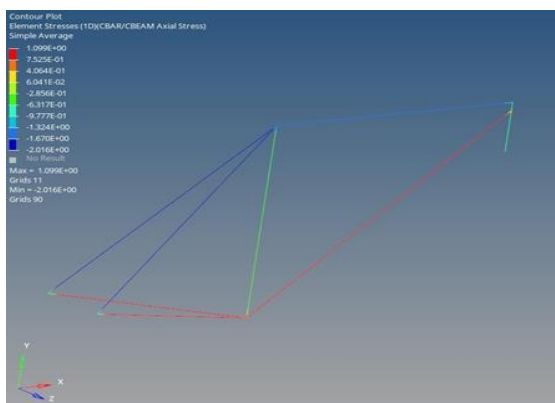

Fig. 15. Von mises stress of bamboo bike frame

Comparing the three materials, it is evident that Bamboo provides higher displacement, indicating a more flexible structure. Aluminum showcases an intermediate level of displacement, while Steel demonstrates the least flexibility with minimal displacement. The Von Mises stresses across all materials are relatively close, suggesting comparable strength characteristics. These results contribute valuable insights into the material-specific responses, aiding in the subsequent stages of the finite element analysis and optimization process.

### B. 3D Results

The 3D static analysis of the bamboo bike frame, representing the design space rather than an exact frame, yielded insightful results. The obtained values are summarized in the table (V), followed by a detailed discussion.

Table V: 3D bamboo frame results

Parameter	Value
Total Displacement	0.6984 mm
Von Mises	87.86 MPa
Yield Strength	142 MPa
Ultimate Strength	265MPa

The total displacement of 0.6984mm (Fig 16) indicates the maximum deformation within the sitting area of the bike frame. This result suggests a degree of flexibility in the bamboo

frame, allowing for some deformation under applied static loads.

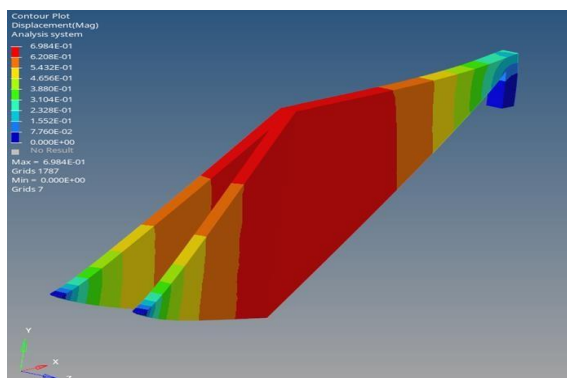

Fig. 16. Maximum displacement

The Von Mises stress distribution (Fig 17) highlights the critical areas, with the maximum stress occurring at the rear drop-outs. The stress value of 87.86MPa is within the material's yield strength, indicating elastic deformation without permanent damage. This is crucial for the structural integrity of the frame.

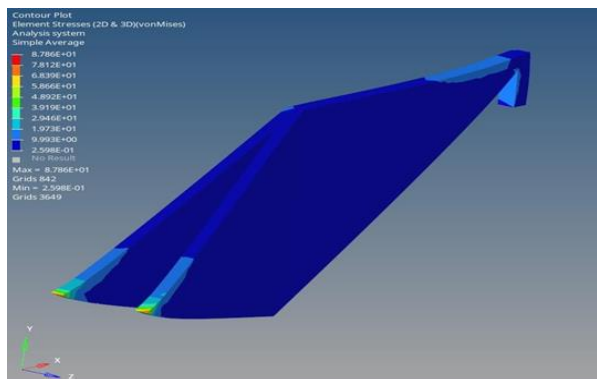

Fig. 17. Von mises stress

**C. Comparison with Material Strength**

The yield strength of bamboo is determined as 142MPa, and the ultimate strength is 265MPa [12]. Comparing these values with the Von Mises stress, it is evident that the frame's stress level is well below the yield strength. This implies that, under the applied loads, the bamboo frame remains within its elastic deformation range, preventing any permanent structural damage.

**D. Implications for Design**

The observed total displacement and stress distribution provide valuable insights for the design considerations of the bamboo bike frame. The flexibility of the frame allows it to absorb and distribute stress, contributing to a comfortable riding experience. The stress levels well below the material's yield strength ensure that the frame maintains its integrity during standard operating conditions. The 3D static analysis results demonstrate the structural behavior of the bamboo bike frame. The observed deformation and stress distribution align with expectations for a material with inherent flexibility.

These findings contribute to the understanding of the bamboo frame's mechanical response, guiding further optimization and design enhancements.

**E. Topology Optimization Results**

The topology optimization process resulted in a refined and efficient design for the bamboo bike frame, as illustrated in Fig (18).

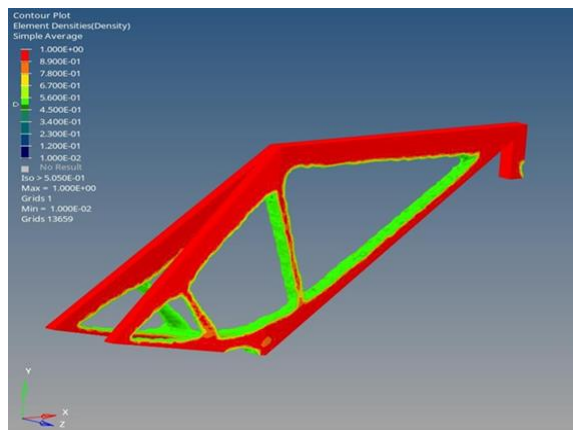

Fig. 18. Optimized design of bamboo bike frame

The optimized frame exhibits a strategic distribution of material, successfully achieving the set objectives of weight reduction and strength maximization. The utilization of HyperMesh for preprocessing proved instrumental in establishing the design variables and preparing the model for optimization. The implementation of constraints, particularly the upper bound on volume fraction, ensured a balanced approach to material reduction, preventing excessive utilization. The optimization control panel, configured with discreteness and checkerboard values, played a pivotal role in guiding the convergence process, leading to a design that aligns with dominant structures and manufacturing constraints as show in Fig (18).

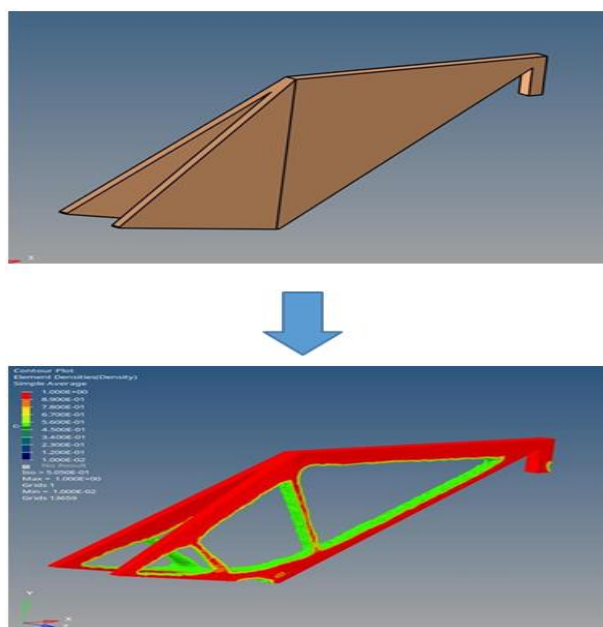

Fig. 19. Initial to optimized design



In Fig (19), we present the optimized bamboo bike frame resulting from the topology optimization process. A careful examination reveals a refined and strategically modified structure. The optimization algorithm, guided by the predefined objectives and constraints, has effectively redistributed material to enhance the frame's performance. Key features include an reduction in weight, contributing to improved efficiency and manoeuvrability, and a maximization of strength, ensuring safety and durability. Overall, the topology optimization results demonstrate the efficacy of the approach in achieving a well-balanced and optimized bamboo bike frame design

IV. VALIDATION THROUGH SIMULATION

The finalized and optimized bamboo frame design was subjected to various simulated real-world scenarios and conditions to ensure that it meets the desired performance criteria.

A. 1D Analysis for Optimized Design

The validation phase began with a detailed 1D analysis of the optimized bamboo bike frame design. This analysis was primarily focused on assessing two key aspects: deformation and weight reduction. The objective was to ascertain the extent to which the optimization process had enhanced the frame's structural performance and reduced its overall weight.

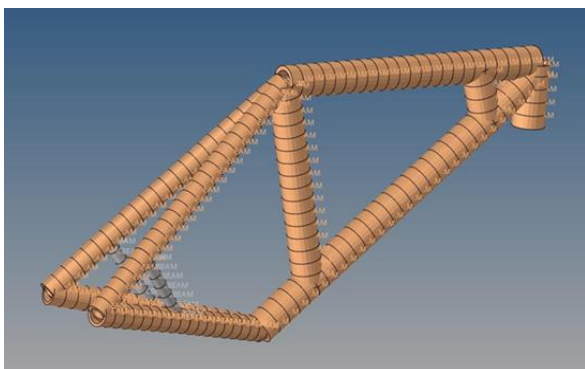

Fig. 20. Optimized design model

The results of the 1D analysis for the optimized design of the bamboo bike frame are presented in Fig (21) and (22) respectively. Fig (21) illustrates the element stresses of the optimized model, indicating a value of 0.6077MPa. This stress value is crucial in assessing the structural integrity of the frame, revealing how the material responds to applied loads. A stress value within this range suggests that the bamboo bike frame is experiencing relatively low levels of stress, indicating a design that can effectively handle the expected mechanical forces.

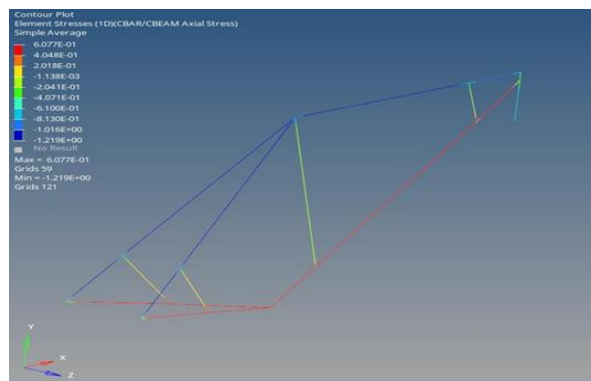

Fig. 21. Element stresses of optimized model

Fig (22), on the other hand, shows the total displacement of the optimized model, which measures 0.09049mm. The total displacement is a key parameter in understanding the flexibility and deformation characteristics of the bamboo bike frame. A displacement value within this range indicates that the frame exhibits a controlled level of deformation under the applied loads. This controlled deformation is desirable as it ensures that the frame maintains its structural integrity and stability during operation.

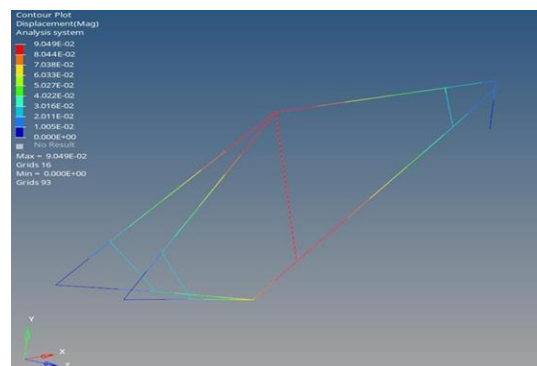

Fig. 22. Total displacement of optimized model

B. Comparison with Initial Design

In the comparison of the results between the 1D analysis of the optimized design and the initial 3D analysis of the bamboo frame, notable differences were observed as shown in table (VI). The 3D analysis indicated Von Mises Stress of 87.86 MPa and a Total Displacement of 0.6984 mm, while the subsequent 1D analysis on the optimized design revealed Von Mises stress of 0.6077 MPa and Total Displacement of 0.09049 mm. The variance in results can be attributed to the differing nature of the analyses. In the 3D analysis, loads were applied on the surfaces, providing a comprehensive representation of stress distribution and displacement throughout the three-dimensional structure. On the other hand, the 1D analysis, utilizing point loads, simplified the structure, potentially leading to discrepancies in stress and displacement values.



Table VI: Comparison between 3D and 1D analysis results

Analysis Type	Von Mises Stresses (Mpa)	Total Displacement (mm)
3D Analysis	87.86	0.6984
1D Analysis	0.6077	0.09049
Yield Strength	142	-

Despite the variations, both analyses show that the Von Mises stress values are well below the yield strength of bamboo (142 MPa), indicating a favourable safety margin. This suggests that, even under different analysis methods, the bamboo bike frame remains within its structural limits, demonstrating resilience and suitability for practical applications.

C. Benchmarking against Steel and Aluminum Frames

To further validate the effectiveness of the optimized bamboo frame, its performance was benchmarked against frames made of steel and aluminium. This comparison extended to both deformation characteristics and weight. The objective was to evaluate if the optimized Bamboo frame’s deformation and weight were comparable to or better than those of frames made from traditional materials like steel and aluminium. This benchmarking was crucial to establish the optimized bamboo frame’s competitiveness in terms of both structural integrity and weight efficiency.

Table VII: Benchmarking of bamboo against aluminum and steel bike frame

Material	Initial 1D Deformation (mm)	Optimized 1D Deformation (mm)	Total Mass (ton)
Bamboo	0.1371	0.09049	2.448e-3 (2.22kg)
Aluminum	0.0307		3.553e-3 (3.2kg)
Steel	0.0108		5.241e-3 (5kg)

V. FINAL CAD MODEL

A detailed CAD model of the bamboo bike frame was created using SolidWorks, a widely-used and precise computer-aided design (CAD) software. The Final CAD model represents the optimized bamboo bike frame, incorporating findings from the thorough analysis and simulation phases. SolidWorks was employed to generate an accurate and visually clear model, allowing for a close examination of the design details. The use of SolidWorks in this phase highlights the importance of user-friendly CAD tools in translating theoretical insights into practical and refined designs. This Final CAD model signifies dedication of the research to achieve a well-balanced design in terms of structure, optimization, and visual appeal in bamboo bike frame construction.



Fig. 23. Final CAD model

VI. CONCLUSION

In conclusion, the comprehensive investigation into Finite Element Analysis (FEA) and optimization of bamboo as a material for bicycle frames has provided valuable insights into its structural performance and sustainability. The utilization of FEA techniques, including 1D and 3D analyses, along with topology optimization, facilitated a detailed understanding of bamboo's behaviour under varying loads and conditions. The optimized bamboo frame exhibited a significant reduction in deformation, as evidenced by the 1D analysis, with the initial deformation of 0.1371 mm decreasing to 0.09049 mm. This reduction underscores the structural efficiency achieved through the optimization process. Furthermore, this research demonstrated that the optimized bamboo frame not only achieved a reduced deformation, as discussed in the results section, but also maintained a competitive mass. The total mass of the bamboo frame, amounting to 2.448e-3 tons (2.22 kg), was notably lighter than both aluminium (3.553e-3 tons or 3.2 kg) and steel (5.241e-3 tons or 5 kg). The results underscore the viability of bamboo as a lightweight and sustainable alternative for bicycle frames Construction. The combination of reduced deformation and lower mass positions bamboo as a promising material for enhancing the efficiency and environmental sustainability of bicycle frames

VII. FUTURE WORK

A. Anisotropic Analysis of Bamboo Material

In the future phase of this research, there is a critical need to explore and integrate the anisotropic nature of bamboo into the analysis. This identified limitation underscores the significance of prioritizing this aspect in future research to enhance the overall understanding of bamboo's mechanical characteristics in bicycle frame applications.

B. Dynamic Analysis and Experimental Validation

Incorporating dynamic analysis would provide insights into the behaviour of the bamboo bike frame under varying loads and conditions. Additionally, experimental validation is imperative to verify the accuracy of the numerical simulations and to ensure the reliability of the proposed design.

## VIII. REFERENCES

- [1] Teatum, S. J., Pyakuryal, B., Arnone, J. R., Blanchard, R. H., Conte, M. H., Harasimowicz, R. P., Johnston, S. R., Trumbley, A. W., Shen, L., Beall, J. D., Valentine, D.E., & Longhurst, K.M.(2015, April30). Engineering a BambooBicycle.Digital.wpi.edu.  
[https://digital.wpi.edu/concern/student\\_works/9593tw96b?locale=en](https://digital.wpi.edu/concern/student_works/9593tw96b?locale=en)
- [2] Kingsley, U. (2011). Development of an Eco-Friendly Bamboo Bicycle. Wwww.academia.edu.  
[https://www.academia.edu/646881/Development\\_of\\_an\\_EcoFriendly\\_Bamboo\\_Bicycle](https://www.academia.edu/646881/Development_of_an_EcoFriendly_Bamboo_Bicycle)
- [3] Bhonde, D. (2013). Tension Test on Male Bamboo (Dendrocalmus Strictus). Wwww.academia.edu.  
[https://www.academia.edu/11675842/Tension\\_Test\\_on\\_Male\\_Bamboo\\_Dendrocalmus\\_Strictus\\_](https://www.academia.edu/11675842/Tension_Test_on_Male_Bamboo_Dendrocalmus_Strictus_)
- [4] ASM Material Data Sheet (2015). Asm.matweb.com.  
<https://asm.matweb.com/search/SpecificMaterial.asp?bassnum=MA6061T6>
- [5] Bamboo Bikes and Bamboo Bicycles ~ Advantages of Bamboo. (2014, September 1).Go Green Travel Green.  
<https://gogreentravelgreen.com/advantages-bamboo-bicycle-bamboo-bikes/>
- [6] Margetin, M., Chmelko, V., Sulko, M., Ďurka, R., & Koščo, T. (2022). Fatigue Lifetime Analysis of a Bicycle Frame Made by Additive Manufacturing Technology from AlSi10Mg. *Metals*, 12(8), 1277. <https://doi.org/10.3390/met12081277>
- [7] Soden, P. D., Millar, M. A., Adeyefa, B. A., & Wong, Y. S. (1986). Loads, Stresses, and deflections in Bicycle Frames.*The Journal of Strain Analysis for EngineeringDesign*, 21(4), 185–195.  
[https://www.academia.edu/40176104/LOADS\\_STRESSES\\_AND\\_DEFLECTIONS\\_IN\\_BICYCLE\\_FRAMES](https://www.academia.edu/40176104/LOADS_STRESSES_AND_DEFLECTIONS_IN_BICYCLE_FRAMES)
- [8] Akhyar, Husaini, Iskandar, H., & Ahmad, F. (2019). Structural Simulations of Bicycle Frame Behaviour under Various Load Conditions. *Materials Science Forum*, 961, 137–147.  
<https://doi.org/10.4028/www.scientific.net/msf.961.137>
- [9] Sharma, V. (2017). Article ID: IJMET\_08\_07\_195 Cite this Article: Vidin Kumar, Sugandh Gupta and Anker Sachdeva Experimental and Numerical Analysis of Ground Effect of A Typical RIV (Reusable Launch Vehicle). *International Journal of Mechanical Engineering and Technology (IJMET)*, 8(7), 1763–1774.  
[https://iaeme.com/MasterAdmin/Journal\\_uploads/IJMET/VOLUME\\_8\\_ISSUE\\_7/IJMET\\_08\\_07\\_195.pdf](https://iaeme.com/MasterAdmin/Journal_uploads/IJMET/VOLUME_8_ISSUE_7/IJMET_08_07_195.pdf)
- [10] Fierro, J. P. A., Fierro, J. L. A., & Suárez, H. E. J. (2019, October 30). *Structural Evaluation of Bamboo Bike Frames: Experimental and Numerical Analysis*. Wwww.intechopen.com; IntechOpen.  
<https://www.intechopen.com/chapters/69814>
- [11] Tetrahedral Element - an overview | ScienceDirect Topics. (2014). Sciencedirect.com.  
<https://www.sciencedirect.com/topics/engineering/tetrahedral-element>
- [12] Richards-Gustafson, F. (2022). Tensile Strength of Bamboo vs. Wood | eHow.com. EHow.com.  
[https://www.ehow.com/info\\_12150266\\_tensile-strength-bamboo-vs-wood.html](https://www.ehow.com/info_12150266_tensile-strength-bamboo-vs-wood.html)