

HUMAN DETECTION SYSTEM USING IoT

Mr. Justine Mathew , Mr. Kichu Dileep , Mr. Sreeraj S , Mr. Tomin Thomas
, Ms. Renju Renjith

Assistant Professor, Dept. of CSE , Mangalam College of Engineering
Ettumanoor, Kerala, India

Justinemathew234@gmail.com, dkichu452@gmail.com, tominthomas356@gmail.com, sreerajs00000@gmail.com

Abstract— Natural calamities do occur and they are unstoppable. Thousands of people killed as a cause of disaster like earthquake. These words aren't the headlines of the newspaper but such news come after the disaster destroyed the field. The disaster in the New York City at 'World Trade Center' claimed lives of more than 5000 people. It was said if survivors has been found and rescue earlier the numbers of victims have been lower. There is no end to the number of lives lost as the result of such disasters as landslides, collapsed tunnels and avalanches. This project aims to give a practical design to build the first and simplified version of a rescue robot which has to be active within disaster areas like collapsed buildings where rescue teams cannot operate due to a lot of technical difficulties, which is connected by a smartphone via IoT. It will better to utilize some technically efficient equipment to achieve such mission rapidly and effectively. Microwave radar sensor is used for the search and rescue of victims trapped under the rubble of collapsed building during the earthquake or other disasters. By advent of this system the world death rate as a cause of an earthquake may decrease to greater extent.

I. INTRODUCTION

Nowadays disasters are unpredictable. Natural disasters like floods, earthquakes and other geologic processes and manmade situations like bomb explosion, building collapse occur regularly and they cannot be predicted in advance to take necessary precautions. The change in atmospheric conditions and climatic changes are occurring in a rapid fluctuating manner. A disaster is a serious problem occurring over a short or long period of time that causes widespread human, material, economic or environmental loss which exceeds the ability of the affected people or community to cope using its own resources. Disaster risk management activities are designed to increase the resilience of people, communities, society and systems to resist, absorb, accommodate and to recover from and improve well-being in the face of multiple hazards. Activities for reducing and managing risks can therefore provide a way for building resilience to other risks. Most of the victims of earthquakes or other natural disasters in the world are trapped or locked under obstacles or rubbles or even under soil. There are systems which is used in disaster areas including detection of human presence using different radars. In the case of a disaster like earthquake the rescue operation is over a wide area under most

difficulties. In the introduced system a Micro wave radar sensor is used in the robot to detect human presence. The robot is controlled by a smartphone-remote control and it should move with substantial speed in all directions that the user desires. By using this system we can reduce the operation to the possible areas of human presence detected without wasting time. Time is the fact that the survivor life truly depends on. How much time can be reduced for an operation is an important factor of lives. Once a human target is located the system has to give an buzzer as well as a notification which may help to identify and localize the victim location as soon as possible.

II. LITERATURE SURVEY

IOT based live human detecting robot for earthquake rescue operation, in this is paper they used the micro controller PIR, DC GEAR MOTOR, INTERNET OF THINGS (IOT), MAX 232 IC, this robot mainly built for the save sensor disaster here they have been connected PIR sensor to detect the presence of human or not they had used microcontroller pic 16f877a to make automation. Easy to the control with Bluetooth module were installed in it. From this they will get information Unmanned Vehicle to Detect Alive Human During Calamity, this is the paper they used ARM7 controller with a highly efficient low cost camera to capture image and detects human body through MATLAB Software using the Viola-Jones algorithm and a set of sensors like Pulse sensor and Temperature sensor will give the information regarding an alive human presence will give the information regarding an alive human presence. IR sensor is used in this project to avoid obstacles in its navigation path. An Unmanned vehicle navigates through the debris automatically to check the presence of human life and it display it through a Zigbee. Human Detection Robot For Disaster Management, In this paper they used Arduino Uno Microcontroller, Robot Chassis, PIR (Passive Infrared) sensor for detecting the human presence and controlling the robot, In this they used a buzzer for alerting the presence It is a simple, yet efficient equipment to indicate casualties and help them with immediate access to first aid

A Modern Microwave Life Detection System For Human Being Buried Under Rubble, in this paper the system utilizes L – Band frequency which is able to detect respiratory and heart fluctuations. The main operation principle is based on Doppler frequency of the electromagnetic wave it will be reflected from buried body.

In this paper titled, “IoT Based Rescue Robot for Alive Human Detection and Health Monitoring System” In this paper they used Arduino mega 2560 the main aim of the

system is to detect the alive human beings in natural and man-made disasters. The IR sensor are use located it immediately gives audio alert visual alert to the authorities, so that help can reach the live person faster. PIR sensor is used to detect the buried persons. Two DC motors are used to drive the robot. Microcontroller Based Tracking System, in this model they had built the robot using 8-bit Microcontroller AT89C51. It is control the robot by using the RF remote control. In remote there will be HT12E which encodes the parallel data into serial data. In receiver section there will be HT12D it will convert into parallel data. Infrared sensor. By alive human temperature will be 96 degrees from the body temperature it will give alerts signal by buzzer sound.

Human detection robot, In this paper they provides the process of Human detect through IOT. In this they use PIR sensor to detect the presence of human being under the soil, they use infrared sensor for finding out the obstacles present in the affected places. The camera is used sending live video and images. microcontroller are PIR sensor, Temperature and Heart rate sensor.

A design of human detection robot using sensor, in this they use ATMEGA 1608 micro controller as the main component. Mainly it is based on it have two section receiver side and transmitter side. The transmitter section the robot controlled by remote. If the remote unable to control it. It can be controlled by pc. It can be controlled in manual and automatic mode. In manual using RS232 logic they will give commands in automatic mode the robot will navigate automatically. If there is any human body is present the PIR sensor will detect him, for safety purpose they had connected gas sensor & fire sensor, and then wireless camera had been fixed on it, for every few minutes it sends photos and videos of the affected areas

III. PROPOSED SYSTEM

The proposed system consist of transmitter side and receiver side. The transmitter unit comprises of the IoT dashboard(Smartphone) which controls the the movement of the motor driver in receiver side and also the communication between both ends. The receiver unit comprises of microwave radar sensor, ultrasonic sensor, power supply, ESP camera, motor driver, Left motor ,Right motor, ATmega1608 microcontroller, WIFI-ESP8266 and alerting buzzer. Figure 1 depicts the work flow of the proposed system

i. Implementation

Initially the robot navigates in an open area and provided with ultrasonic sensor, which detects the obstacles on its path of movement. If obstacles are found that should be notified into the controlling device. The robot consists of two DC motors along with a motor and it should move with substantial speed in all directions that the user desires, that is, forward, backward, left , right. Blyn software is used in the IoT dashboard for controlling movements of the robot.

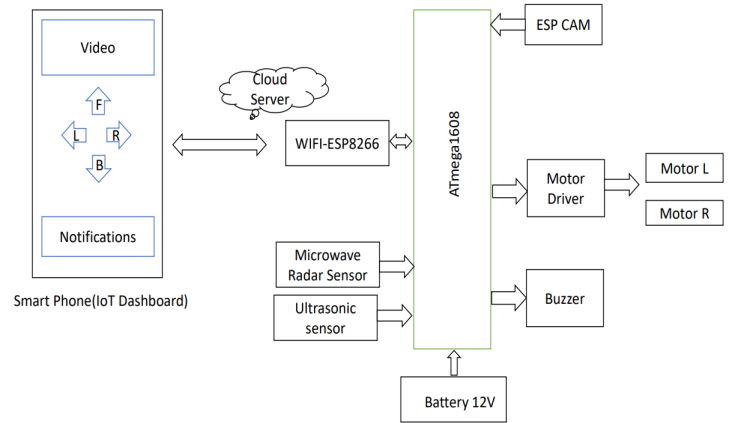

Fig. 1: Conceptual model

In this proposed methodology, ultrasonic is used for navigation purpose. Mainly microwave radar sensor is used for detecting the presence of human. When the microwaves emitted by the sensor senses a human body under the soil it get reflected to the robot and is notified on the transmitter side as notification in IoT dashboard through cloud server. Then vehicle will move towards the affected human for some distance. Pulse rate sensor will activates and checks pulse rates of human to find whether human is alive or not. ESP cam is used for providing live streaming for persons who monitoring the disaster affected area. The application of modern IoT and cloud technologies makes controlling of the device globally. That is the robot can be controlled and monitored from any part of the world during the rescue operation. The data regarding a operation can be stored in the cloud and can be used during future operations.

System hardware requirements

A) ATmega1608 microcontroller

ATmega1608 is a microcontroller board supported by ATmega328P semiconductor unit. It has 14 digital input/output pins (of which 6 can be used as Pulse Width Modulated outputs), 6 analog inputs, a 16 MHz ceramic resonator, a USB connection, a power jack, and a reset button. Human detection module of the robot controlled by an Arduino microprocessor. When an individual is present within the range of the sensing element it creates a detection signal (a digital pin goes high) that is processed by Arduino and a (LED signal will glow on to indicate the direction. Here Arduino is used for controlling and coordinating operations in the circuit

B) Microwave radar sensor

Microwave radar sensor is sensor that detects human presence within its operating range. They work entirely by motions in objects under the soil.

C) DC motor

A DC motor is a rotating electrical motor that converts DC electrical energy into mechanical energy. These motors consume electrical power through direct current and convert

this electrical energy into mechanical rotational motion. Here DC motors are used for the rotation of robot wheels

D)Ultrasonic sensors

Ultrasonic sensors are sensors used to find obstacles that prevents the workflow of the object detection system

E)Battery

A battery is an integration of one or many cells where the chemical reactions create flow of electrons, which in turn results in production of current. The positive terminal of the battery is called as the cathode and its negative terminal is the anode. The electrons will flow from anode to the cathode through an electrical circuit which will be connected externally. Here we have used a 9 Volt battery for powering up the robot wheels.

F) Buzzer

Buzzer is an indication device. It is used in an alarm circuit or any other audio output circuit. Basically, it converts audio signals into sound signals. Here it is used in parallel with LED to indicate whether human trace is detected or not.

G)ESP cam

ESP cam is used for the live streaming of the area under observation from receiver side.

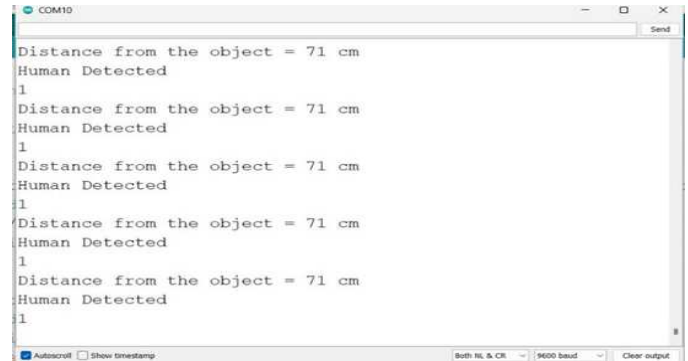

Fig. 3: Distance range

Any obstacles in the movement of the system is identified by the ultrasonic sensor and buzzer rings which can be seen by the team. Fig 4 depicts the IoT dashboard image and the schematic view of the human presence detected.



Fig. 4: represents the user interface IoT dashboard

IV.EXPERIMENT AND RESULTS

Several experiments are performed with the human detection system. The individual units of the system such as microwave radar sensor , ultrasonic sensor etc are tested for specification. The fig(2)- graph represents testing of the microwave radar sensor and graphical plotting of the human presence detected. The y axis plot the distance from the victim . Fig(3) represents the corresponding reading of the distance in digital form .

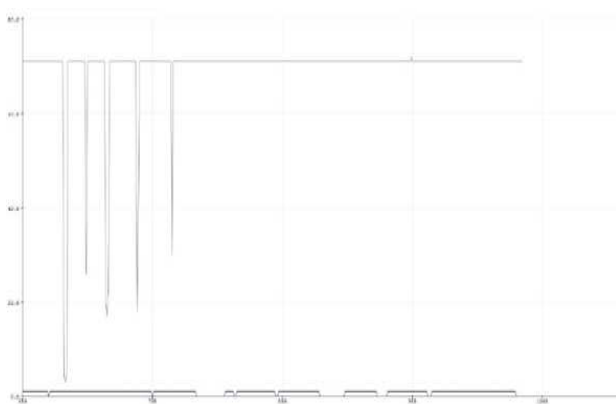

Fig. 2: graphical representation of the microwaves detected from radar.

V. CONCLUSION

A simple, efficient solution for helping rescue workers in disaster management. As it is a wireless model, the system can enter into any area. It is very efficient in hazardous environments. The microwave sensor increases the efficiency of the system.

We believe that through the development of similar and related techniques for life detection system, it will be possible to overcome the current fundamental problems in detecting buried victims and save many precious lives.

VI. REFERENCES

- [1] Zade Gauri N, Badnerkar S, “A modern microwave life detection system for human being buried under rubble,” International Journal of Adavaned Engineering Research and Studies , E-ISSN2249-8974
- [2] Murulidhara T C, C. Kanagasabapathi, Siva S Yellampalli, “Unmanned Vehicle to Detect Alive Human During Calamity” , 7 International Conference on Electrical,

- Electronics, Communication, Computer and Optimization Techniques (ICEECCOT)-2017
- [3] Gopika D, Hrithik Sivadasan, Pooja Jiresh, Sucheta G S, "HUMAN DETECTION ROBOT FOR DISASTER MANAGEMENT," International Journal of Engineering Applied Sciences and Technology, 2021 Vol. 5, Issue 10, ISSN No. 2455-2143, Pages 193-199.
- [4] Sandeep Bhatia, Ajay Mudgil, and AmitaSoni prepare and issue a paper on the topic "Alive Human Detection Using an Autonomous Mobile Rescue Robot", Department of Electrical and Electronics, PEC University of Technology, Chandigarh, India Vol. 02, July [2010]R. Nicole, "Title of paper with only first word capitalized," J. Name Stand. Abbrev., in press.
- [5] Zia Uddin, Mojaharul Islam, "Search and Rescue System for Alive Human Detection by Semi autonomous Mobile Rescue Robot" International Conference on innovations in science engineering and technology, 2016.M. Young, The Technical Writer's Handbook. Mill Valley, CA: University Science, 1989.
- [6] A. Swapna and K.archana (2017). "A new approach for detecting living human beings in devastating environments using a low cost autonomous robot" in International research journal of engineering and technology, vol. 4, no.4(pp. 3078-3081).
- [8] Detecting Direction of Movement Using Pyroelectric Infrared Sensors byJaeseok Yun, Member, IEEE, and Min-Hwan Song.
- [9] Schultz Jean, Jill L. Drury and Holly A. Yanco.(2004). "Evaluation of Human-Robot Interaction Awareness in Search and Rescue" in IEEE (pp. 2327-2332).
- [10] Fahed Awad, Rufaida Shamroukh "Human Detection by Robotic Urban Search and Rescue Using Image Processing andNeural Networks" International Journal of Intelligence Science, 2014, PP. 4, 39-53.
- [11] Steve9Burion "Human-Detection for Robotic:Urban Search and Rescue.
- [12] MauriciofCorrea, Gabriel Herмосilla, Rodrigo Verschae,6 "HumanjDetection and Identificationiby Robotskusing Thermal andlVisual information inrDomestic Environments", J I tell Robot System 2012
- [13] Carlosomarques, PedrotLima, RodrigoyVentura 6"Semi7autonomous robot for rescue poperations" @International Conference onIntelligent Robots and Systems, 4)October 9-15, 52006, Beijing, China.
- [14] Purnima G, Asst. Prof. Aravind S, "Alive Human Body Detection and Tracking System Using an Autonomous Pc Controlled Rescue Robot", International Journal of Emerging Technology and Advanced Engineering, Volume 4, Issue 12,December 2014.
- [15] Geetha Bharathi,0Dr.S.Sudha, "Alive Human Detection in Disaster=Zones using Manually! Controlled Robots", International Journal of Innovative]Research in Computer and Communication Engineering, Vol.03, Special Issue 2,pMarch 2015