

# Implementation of Parallel Interference Cancellation Algorithm for Rake Receiver and Comparison with DS-CDMA

Ms. Samta Jain

Department of Electronics and Communication  
Acropolis Technical Campus, Indore, India

**Abstract-** In order to suppress the Multiple-Access Interference (MAI) in the DS CDMA system, a new RAKE receiver based on parallel interference elimination is proposed in this paper. The multiple-access interference is evaluated by tentative decision and known user information. Then the performance over Rayleigh fading channel are analyzed and compared to conventional DS-CDMA receiver and PIC RAKE receiver. It is shown that RAKE receiver performance can be improved greatly by using Parallel Interference Cancellation (PIC) method with simple structure and easy implementation [1].

**Key words:** Parallel Interference Cancellation (PIC); RAKE receiver; Multiple-Access Interference (MAI); Rayleigh fading.

## I. INTRODUCTION

The CDMA system implemented by the direct-sequence spread spectrum (DS/SS) technique is the most promising multiplexing technology for cellular telecommunications services, such as personal communications, mobile telephony, and indoor wireless networks. The advantages of DS/SS for these services include superior operation in multipath environments, flexibility in the allocation of channels, the ability to operate asynchronously, privacy, and increased capacity in burst or fading channels [2]. One of the most attractive features of direct sequence code-division multiple access (DS-CDMA) systems is the capability of sharing bandwidth with narrowband communication systems without performance degradation of any one of the systems.

It is well known that the processing gain of a spread spectrum system will provide the system with a sufficient capability of interference rejection [3],

[4], [5]. The higher the processing gain is, the better interference rejection the system has [5], [6]. For a moderate level of narrowband interference, the processing gain of the spread spectrum system often provides sufficient capability of interference rejection; hence, a simple despreading correlator can be employed to achieve a good performance. However, if the interfering signal is strong enough, the reliable communication becomes impossible even with the advantage of spectrum spreading. In these cases, the interference immunity can be improved significantly by using signal processing techniques which can complement the spread spectrum modulation.

According to the conventional DS-CDMA system analysis, we find out that the multiple access interference (MAI) is a major problem. Several methods have been proposed to suppress the interference in DS/SS transmission systems [6]. This paper concentrates on developing the parallel interference cancellation (PIC) to achieve a significant improvement in performance and increase the user capacity [7] and to reduce the effects of MAI and utilizes the processing gain with less noise enhancement.

The remainder of the paper is organized as follows. The system model is addressed in Section II. A system description is given in Section III. The DS-CDMA and proposed PIC with RAKE is described in this section. In Section IV, the simulation results and analysis for SNR Vs BER is presented. Finally, the conclusions are given in Section V.

## II. SYSTEM MODEL

### A. Transmitter Model

Considering a single district with  $K$  users, the baseband signal for the  $K^{th}$  user is given by

$$s_k(t) = \sqrt{2E_{ck}} d_k(t) c_k(t) \cos(\omega_c t + \theta_k) \quad (1)$$

Where  $E_{ck}$ ,  $d_k(t)$  stand for the signal power and information stream for the  $K^{th}$  user respectively,  $\omega_c$  is the carrier frequency,  $\theta_k$  is the carrier frequency phase,  $c_k(t)$  is the signature wave for the  $K^{th}$  user,  $T_c$  is the chip width,  $T_s$  is the every symbol width for user information stream. So the spread gain is obtained  $N_c = T_s/T_c$ .

#### A. Channel Model

Rake receivers are designed as taking out delay line model in frequency-selective channel, so the complex lowpass equivalent impulse response can be written as:

$$h(t) = \sum_{l=1}^L \alpha_l e^{j\beta_l} \delta(t - lT_c) \quad (2)$$

In (2),  $L$  is resolvable path number,  $\alpha_l$  and  $\beta_l$  is the gain and phase of the  $l^{th}$  resolvable path respectively,  $\alpha$  obey to Rayleigh distribution in the Rayleigh channel.

#### B. The Receiving Signal

In this thesis, for simplicity, we consider a synchronous uplink CDMA system in the Rayleigh channel, the received signal can be written as

$$r(t) = \sum_{k=1}^K \sqrt{E_{ck}} \sum_{l=1}^L \sum_{j=-\infty}^{\infty} \alpha_{l,k} b_k(j) c_k(t - \tau_{l,k}) \cos(\beta_{l,k} + \theta_k) + n(t) \quad (3)$$

In (3),  $n(t)$  represents the Additive White Gaussian Noise (AWGN) and its power spectrum density is  $\eta/2$ .

#### C. Rake parallel interference canceller

In the PIC with RAKE receiver, the RAKE fingers will separate the paths of rayleigh channel by proving the delay to the received signal. Thus, the output of the correlator can be written as:

$$y_{k,l}(i) = \int_T^{(i+1)T} r(t - iT) c_k(t) dt \quad (4)$$

$$= N\sqrt{E_{ck}} \alpha_{k,l} b_k(i) + \sum_{\substack{k'=1 \\ k' \neq k}}^K \sqrt{E_{ck'}} \sum_{l=1}^L \alpha_{k',l} b_{k'}(i) \rho_{k',k} + n_k(i) \quad (5)$$

$$= \sqrt{E_{ck}} \alpha_{k,l} b_k(i) + I^M + n_k(i) \quad (6)$$

Where:

$$\rho_{k',k} = \int_0^T c_k(t) c_{k'}(t) dt \quad (7)$$

In (6), the first item stands for signal; the second item is the multiple access interference (MAI) of the other  $(K-1)$  users to the  $K^{th}$ ; the last is the additive white Gauss noise (AWGN) and its average square error is  $N\eta/2$ .

### III. SYSTEM DESCRIPTION

The comparison of DS-CDMA with PIC-RAKE receiver is explained in this section as follows:

#### A. DSSS-CDMA

It is well known that in DS-CDMA systems all mobiles share the same bandwidth and are distinguished by their unique spreading codes [8]. Non-orthogonality between mobiles' spreading codes manifests themselves as mutual interference to other mobiles. For this reason, DS-CDMA systems are often termed to be interference-limited.

Figure 1 shows the simulation model of conventional DS-CDMA receiver. As shown in fig.  $r(t)$  is the received signal defined by equation (3). This received signal is spreaded signal, so it is first despreaded using despreader in which the signature wave  $c_k$  is multiplied with the received signal. Then this despreaded signal is demodulated using demodulator in which BPSK demodulator is implemented and final bit error is calculated.

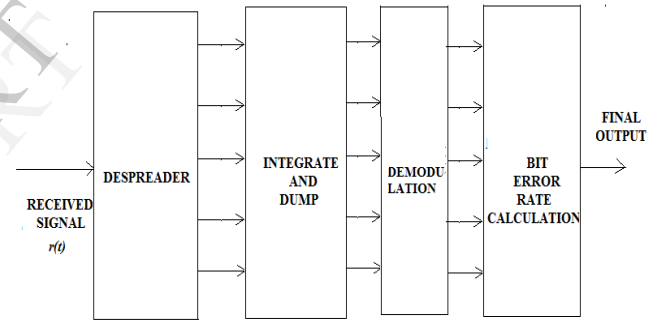
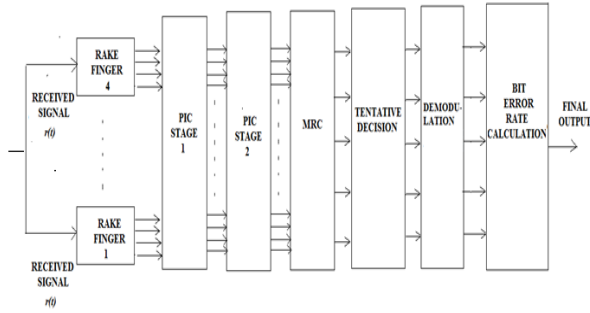

Figure 1: Simulation model of conventional DS-CDMA receiver.

#### B. Parallel Interference Canceller (PIC) with RAKE Receiver

According to the conventional DS-CDMA system analysis, we find out that the multiple access interference (MAI) is a major problem. However, we use the parallel interference cancellation (PIC) to achieve a significant improvement in performance and increase the user capacity [9].

The fig.2 shows the simulation model for PIC with RAKE receiver. RAKE fingers are used to separate the path of multi-path channel, since four paths channel is assumed, it is four fingers are used. After separation of the paths the signal is given to the PIC stages, where interference is cancelled out parallel.



**Figure 2: Simulation model for PIC with RAKE receiver**

We consider a PIC scheme that could be a single stage shown in figure 3. In this scheme, we shall assume that received signal is the sum of K users signal. If it is perfect cancellation, one would theoretically need exact knowledge of the data bits corresponding to all of the other K-1 users. Since indeed this information is unknown, the above theoretical assumption is practically invalid. However, by replacing exact knowledge of the other K-1 users bits by estimation of other values, we arrive at an iterative scheme wherein each stage of the iteration produces new and better estimates of the user bits based upon those obtained in the previous stage. This iteration scheme is used in multi-stage PIC.

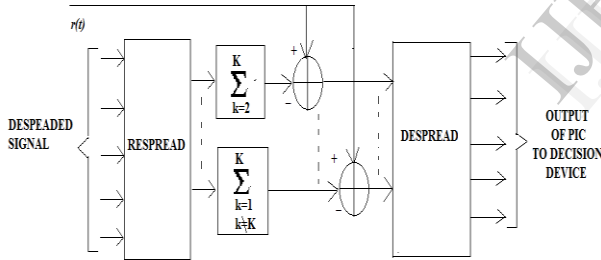

**Figure 3: Simulation Model of One Stage PIC**

After interference cancellation the signal is given to traditional Rake receiver, the result using maximum ratio combining is [10]:

$$y_k(i) = \sum_{l=1}^L \tilde{\alpha}_{l,k} y_{k,l}(i) \quad (8)$$

In (8),  $\tilde{\alpha}_{l,k}$  is the evaluation value for the  $k^{th}$  user in the  $l^{th}$  path.

When (8) is decided, the tentative test value about the symbol is obtained as:

$$\tilde{b}_k(i) = D(y_k(i)) \quad (9)$$

In (9), D(.) stands for decision function, which may be hard decision or soft decision. Traditional PIC adopts hard decision. In this paper, we use simplified soft decision---linear decision.

**IV. SIMULATION RESULTS AND ANALYSIS**

**A. Simulation results for conventional DS-CDMA**

Figure 4 shows the results of conventional DS-CDMA on the basis of number of users. The parameters are chosen as: number of users K is 1, 5 and 10, the value of spread factor  $N_c$  is 32, the length of data bits sent is 1000 and the number of paths of Rayleigh Fading channel l is 4.

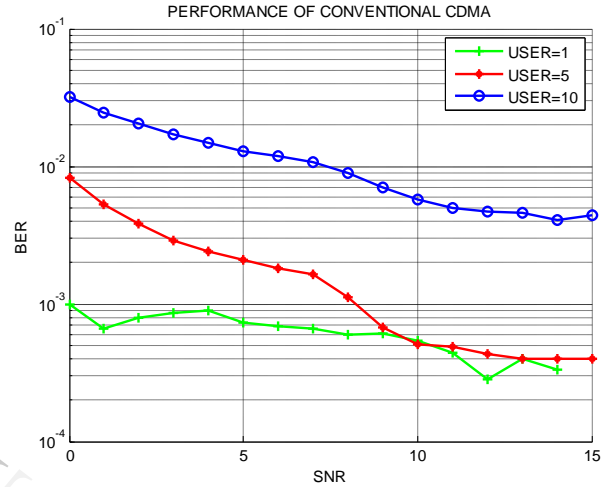

**Figure 4: Performance of Conventional CDMA for Different Users**

Figure. 5 show the result of conventional DS-CDMA on the basis of different spread factor. The number of users K is 5.

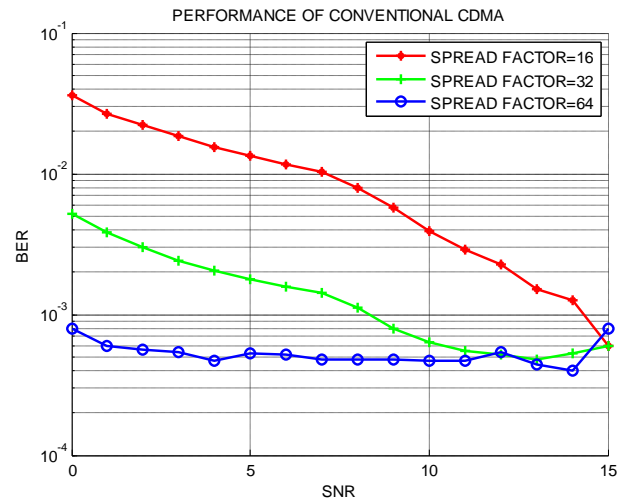
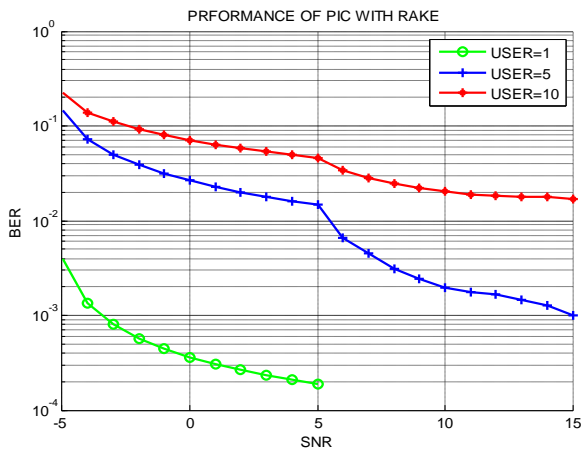

**Figure 5: Performance of Conventional CDMA for different values of Spread Factor**

**B. Simulation Results for PIC with RAKE**

Figure.6 shows the performance comparison of conventional PIC for different number of users.

The parameters are chosen as: number of users  $K$  is 1, 5 and 10, the value of spread factor  $N_c$  is 32, the length of data bits sent is 1000 and the number of paths of Rayleigh Fading channel  $l$  is 4.



**Figure 6: Performance of PIC with RAKE for different Users**

Figure. 7 show the performance of PIC with RAKE for different Spread Factor. The number of users  $K$  is 5.

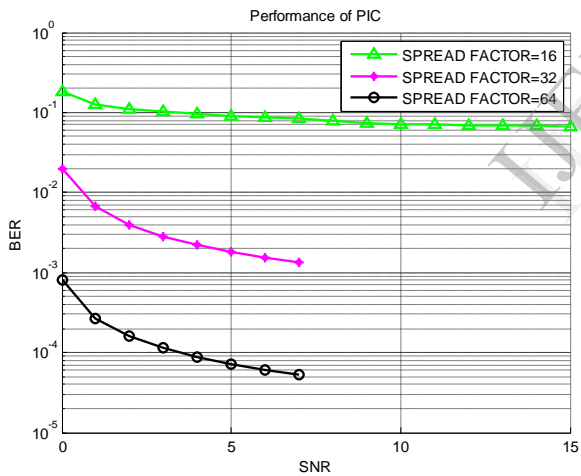

**Figure : 7 Performance of PIC with RAKE for different Spread Factor**

*C. Comparison Result of DS-CDMA and PIC with RAKE*

Figure. 8 show the results of comparison of conventional DS-CDMA and PIC with RAKE. The parameters are chosen as: number of users  $K$  is 5, the value of spread factor  $N_c$  is 64, the length of data bits sent is 1000 and the number of paths of Rayleigh Fading channel  $l$  is 4.

In Figure. 8, the parallel interference cancellation algorithm based on linear decision proposed in this paper is compared with conventional DS-CDMA. Each  $L$  of them is 4. It can be seen from

Fig.8 that when the signal-noise-ratio (SNR) is lower, the two kind receivers show little difference, but with the SNR increasing, the PIC with RAKE show superior performance than DS-CDMA receiver, especially, the PIC system proposed in this paper appears the best performance.

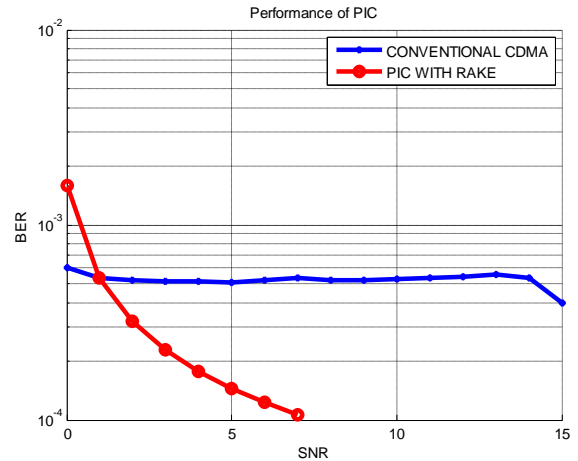

**Table 1: Comparison of Conventional DS-CDMA on the basis of Users and Spread Factor**

DS-CDMA									
Users	1			5			10		
SNR(dB)	0	5	10	0	5	10	0	5	10
BER	$10^{-3}$	$10^{-3.4}$	$10^{-3.5}$	$10^{-2.2}$	$10^{-2.9}$	$10^{-3.5}$	$10^{-1.8}$	$10^{-1.97}$	$10^{-2.4}$
Spread Factor	16			32			64		
SNR(dB)	0	5	10	0	5	10	0	5	10
BER	$10^{-1.7}$	$10^{-1.9}$	$10^{-2.6}$	$10^{-2.5}$	$10^{-2.9}$	$10^{-3.5}$	$10^{-3.2}$	$10^{-3.5}$	$10^{-3.7}$

**Table 2: Comparison of PIC with RAKE on the basis of Users and Spread Factor**

PIC with RAKE									
Users	1			5			10		
SNR(dB)	0	5	10	0	5	10	0	5	10
BER	$10^{-3.7}$	$10^{-3.9}$	0	$10^{-1.8}$	$10^{-1.9}$	$10^{-2.9}$	$10^{-1.4}$	$10^{-1.6}$	$10^{-1.9}$
Spread Factor	16			32			64		
SNR(dB)	0	5	10	0	5	10	0	5	10
BER	$10^{-0.9}$	$10^{-1.1}$	$10^{-1.3}$	$10^{-1.9}$	$10^{-2.9}$	0	$10^{-3.2}$	$10^{-4.3}$	0

Table 1 and Table 2 are showing the performance of DS-CDMA and PIC with RAKE, respectively. The number of users chosen as 1, 5 and 10 and SNR is compared with bit error rate (BER). The values of SRN are taken as 0, 5 and 10 dB.

## V. CONCLUSION

CDMA is a spread-spectrum multi-access technique which is currently the object of much attention. However, this technique suffers from severe reductions in system performance because of Multiple-Access Interference (MAI). In this paper, we have proposed and analyzed a MAI cancellation using PIC with RAKE for DS/CDMA signals over wireless channels that are characterized by multipath fading links. The proposed method, which is based on [1], is a parallel interference cancellation which attempts to cancel the MAI. Numerical results have demonstrated the effectiveness of the proposed method. Finally, it has been shown that the proposed cancellation strategy can alleviate the effects of the MAI and that significant system capacity improvement can be achieved using the proposed detector instead of the conventional DS/CDMA receiver.

## REFERENCES

- [1] Li-xin Song, Zheng-qiang Wang, Xiao-bo Li, "A New Parallel Interference Cancellation Algorithm for RAKE systems" Third International Conference on Genetic and Evolutionary Computing, IEEE Computer Society, 2009
- [2] W. S. Hou and B. S. Chen, "Adaptive detection in asynchronous codedivision multiple-access system in multipath fading channels," *IEEE Trans. Commun.*, vol. 48, pp. 863–874, May 2000.
- [3] J. G. Proakis, *Digital Communications*. New York: McGraw-Hill, 1983.
- [4] B. Widrow and S. D. Stearns, *Adaptive Signal Processing*. Englewood Cliffs, NJ: Prentice-Hall, 1985.
- [5] R. L. Pickholtz, D. L. Schilling, and L. B. Milstein, "Theory of spread spectrum communications: A tutorial," *IEEE Trans. Commun.*, vol. COMM-30, pp. 855–884, May 1982.
- [6] L. B. Milstein, "Interference rejection techniques in spread-spectrum communications," *Proc. IEEE*, vol. 76, pp. 657–671, June 1988.
- [7] Pulin Patel and Jack Holtzman, "Performance Comparison of a DS/CDMA System using a Successive Interference Cancellation (IC) Scheme and a Parallel IC Scheme under Fading," *IEEE*, pp.510-514, 1994.
- [8] H. Holma and A. Toskala, "WCDMA for UMTS. New York, USA", *John Wiley & Sons Ltd.*, 2000.
- [9] Pulin Patel and Jack Holtzman, "Performance Comparison of a DS/CDMA System using a Successive Interference Cancellation (IC) Scheme and a Parallel IC Scheme under Fading," *IEEE*, pp.510-514, 1994.
- [10] Junhui Zhao et. "An Improved Rake Receiver Algorithm of the CDMA System" *Journal of applied sciences*, 2004, 22(3): 298–302.