

Improving Video Quality Using Wimax Emulator

B. A. Waghmode^{#1}, A. C. Kharade^{#2}, S. T. Lokhande^{#3}, S. D. Dhas^{#4}, A. S. Zore^{*5}

[#]Student, Department Of Computer Engineering, University of Pune, MMIT, Lohgaon, Pune, Maharashtra, India.

^{*}Lecturer, Department Of Computer Engineering, University of Pune, MMIT, Lohgaon, Pune, Maharashtra, India.

Abstract:- Today wireless networks are becoming popular because of their "3 Any's" - Any person, Any where, Any time. It is not easy to achieve real-time video transmission testbed on WiMax, due to the lack availability of WiMax networks. This paper presents a ns-2 based emulator to evaluate the quality of video services transmitted over an IEEE 802.16 and an IEEE 802.11 wireless networks. The performance of the proposed emulator was evaluated in both 802.11 and 802.16. Based on the evaluation results, which emulator works better is decided. Specially, the results about the emulator's performance are relevant when real-time services are taken into account. The main contribution in this paper is the general guidelines provided to develop an efficient real-time streaming video testbed on wireless networks, exploiting the potentialities of a tool as ns-2.

Keywords:- ns-2; WiMAX; video streaming test bed.

I. INTRODUCTION

Generally for transmitting videos and anything Wi-Fi technology is used. It is not reliable due to its speed. We are designing our system to remove problems with videos like slow streaming, and slow transmission rate of packets. we will be transmitting our packets through Network Emulator. We are going to use WiMAX technology and RTP for it. WiMAX technology is used over Wi-Fi.

We are going to develop NS2 Emulator so that it can use external packets for simulation. We are using Ns2 for showing all the network virtually. To implement WiMAX physically is not affordable to us, So we are using NS2.

II. WIMAX: THE CONCEPT

WiMAX (Worldwide Interoperability for Microwave Access) is a wireless communications standard designed to provide 30 to 40 megabit-per-second data rates, with the 2011 update providing up to 1 Gbit/s for fixed stations. The name "WiMAX" was created by the WiMAX Forum, which was formed in June 2001 to promote conformity and interoperability of the standard. The forum describes WiMAX as "a standards-based technology enabling the delivery of last mile wireless broadband access as an alternative to cable and DSL".

WiMAX can provide broadband wireless access (BWA). The Fixed Station range of WiMAX is 30 miles (50 km) and Mobile Station range is 3 - 10 miles (5 - 15 km). WiMAX may be suitable for deployment in rural area. The Speed of WiMAX is up to 70 mbps. WiMAX refers to interoperable implementations of the IEEE 802.16 family of wireless-

networks standards ratified by the WiMAX Forum. Similarly, Wi-Fi, refers to interoperable implementations of the IEEE 802.11 Wireless LAN standards certified by the Wi-Fi Alliance. WiMAX Forum certification allows vendors to sell fixed or mobile products as WiMAX certified, thus ensuring a level of interoperability with other certified products, as long as they fit the same profile. The original IEEE 802.16 standard was published in 2001. WiMAX adopted some of its technology from WiBro, a service marketed in Korea.

Mobile WiMAX (originally based on 802.16e-2005) is the revision that was deployed in many countries, and basis of future revisions such as 802.16m-2011. WiMAX is sometimes referred to as "Wi-Fi on steroids" and can be used for a number of applications including broadband connections, cellular backhaul, hotspots, etc. It is similar to Wi-Fi, but it can enable usage at much greater distances.

III. SYSTEM FEATURES

A. RTP (Real Time Transport Protocol)

RTP Protocol In many applications reliability is very important. So we use protocols like RTP, TCP etc. RTP is typically used over the UDP transport protocol. TCP and UDP are the most widely used transport protocols in the Internet. RTP is mainly designed for multicast transmissions. Also RTP doesn't guarantee timely delivery of packets, nor does it keep the packets in sequence. RTP gives the responsibility for recovering lost segments and resequencing of the packets for the application layer. So we have used RTP in our system.

B. WiMax Transmission

1) Description and Priority

The streaming videos are not fast. They always take more time to load. Especially for multimedia data, reliability is not as important as timely transmission. So we are using WiMAX technology for fast transmission. Ultimately qualities of video get improved due to WiMAX.

2) Stimulus/Response Sequences

User means client request for Video packets then Packets will be transmitted through NS-2 emulator Using this feature i.e Wimax. Ultimately transmission rate increased

IV.SYSTEM ARCHITECTURE

The proposed network architecture is shown in Figure 1. In this architecture, one PC is used as a media server and several PCs are used as video clients. One PC running ns-2 is used as a WiMAX network emulator which mimics the impairments introduced by the wireless channel in real-time. The streaming video packets generated by the media server are fed in the WiMAX emulator and then multicast to clients. Each client can then display the received video stream independently. The network simulator ns-2 is a discrete event simulator targeted at networking research.

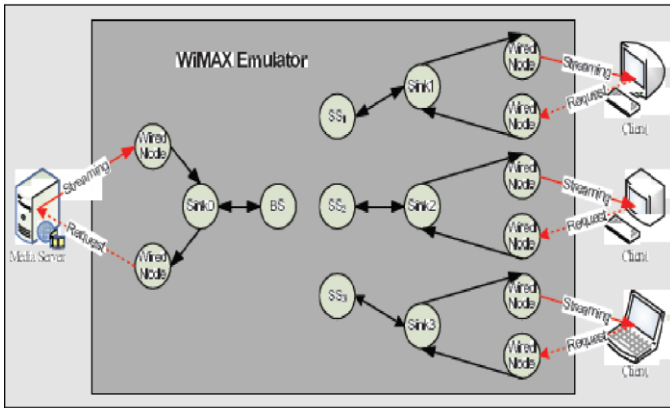

Fig 1: System Architecture

Ns-2 provides modules for simulation of TCP, routing, and multicast protocols over wired and wireless (local and satellite) networks. The same ns-2 WiMAX module used in the system level simulator of WiMAX Forum is also used in our emulator. It implements the main functions specified in IEEE 802.16-2004 and IEEE 802.16e-2005.

V. OPERATING ENVIRONMENT

In the first view it will just look like client server transmission. But client server transmission is going through Ns2 emulator. We can implement client server on any operating system. But it is must to implement WiMAX emulator on Linux. There will be two nodes BS and SS. These nodes will be in Ns2 emulator. For any node in WiMAX network, it can transmit and receive packets from the other nodes. Hence, two wired node modules are needed to implement transmit/receive (TX/RX) functionality. A sink module is used here to assign the TX/RX functionality to a BS or MS.

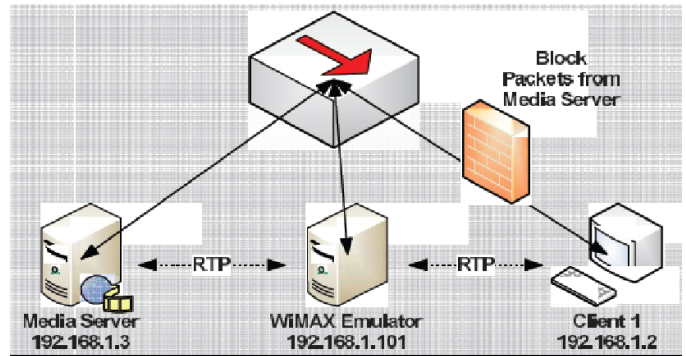

Figure 2: Operating Environment

There is one multicasting device in our environment i.e. Hub for multicasting. We will be using RTP and WiMAX technologies for transmission. So the packets loss automatically get reduced and video quality will be improved.

VI. TECHNICAL OVERVIEW

A. System Implementation Plan

1. Implementation of video transmission from RTP media server to RTP client.
2. Development of NS2 Emulator so that it can use external packets for simulation.
3. Implementation of WiMAX transmission in the NS2 Emulator.

B. Input to and Output from System

Input file to the emulator: Sta_01.Sta_01 is generated through following command. Here a01 is mp4 file we want to send through emulator.

Command: mp4trace -f -s 1.0.1 12346 demo.mp4 > st_a01.

Format of video trace file:

Frame Number	Frame Type	Frame Size	Number of UDP-packets	Sender Time
0	H	24	1 segm	40 ms
1	I	9379	10 segm	80 ms
2	P	2549	3 segm	120 ms
3	B	550	1 segm	160 ms
...				

Output file: Video1.dat

Graphs are generated through trace file

C. Why WiMAX ?

Parameters	Wi-Fi	WiMAX
Transmission Speed	Transmit up to 54Mbps	Handle up to 70Mbps
Range	100 feet (30 m)	Blanket a radius of 30 miles (50 km)
Frequency	5GHz frequency	10-66 GHz frequency
Security	Less security compared to WiMAX	WiMAX proposes the full range of security (Terminal authentication, User authentication)
Standards	IEEE 802.11	IEEE 802.16.
Cost	Low Cost Network	High Cost Network
Quality of Services	User have to sort of fight to stay connected with specified access point	Large number of people get access to tower at same time

Y-axis: Throughput

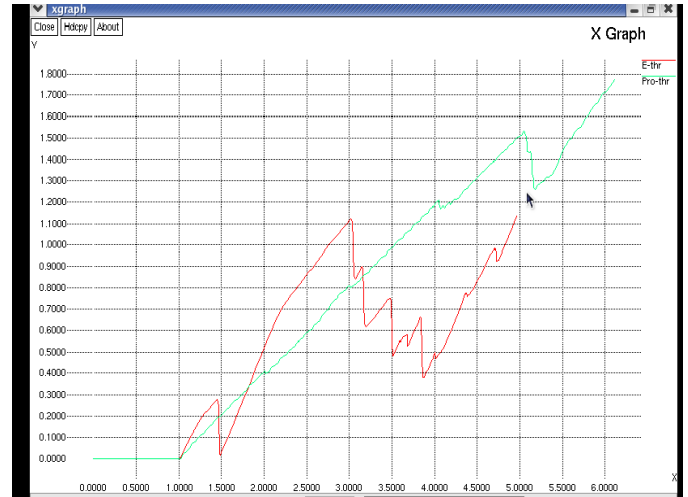

Fig 2: Graph of Throughput

Throughput is number of bytes received per second. In case of Wi-Fi, we can see throughput varying largely, but for WiMAX throughput is slightly varying and more. Due to the slow speed of Wi-Fi retransmissions are more in Wi-Fi, therefore at many points in graph throughput decreases and suddenly increases i.e we can see many spikes in between.

D. Advantages

Our system is more efficient than existing system i.e. Wi-Fi Packet drop ratio is very low in this system. High throughput is achieved every time. Traffic is always controlled due to high speed of WiMAX.

Network overloading never occurs, therefore network performance is always very good.

E. Disadvantages

The main technology used in our system WiMAX. So the disadvantages of WiMAX system are also applicable to our system.

Weather conditions like rain could interrupt the signal. WiMAX is very power intensive technology and requires strong electrical support. While working Ns-2 many compatibility issues occurs, so we have to adjust according to that.

F. Future Scope

Wimax transmission for large networks can tested in the further scope. Simulation of complex WiMAX networks can be done to test accuracy of WiMAX technology. Many other networking parameters can be analysed to get a better understanding of the simulation.

VII.EVALUATION RESULTS

E-thr (Red):- Existing System Throughput (Wi-Fi)

Pro-thr (Green) :-Proposed System Throughput (WiMAX)

X-axis: Time

E-pdr (Green) :- Existing System Packet drop ratio

Pro-pdr (Red) :-Proposed System Packet drop ratio

X axis: Time

Y axis: Packet Drop Ratio

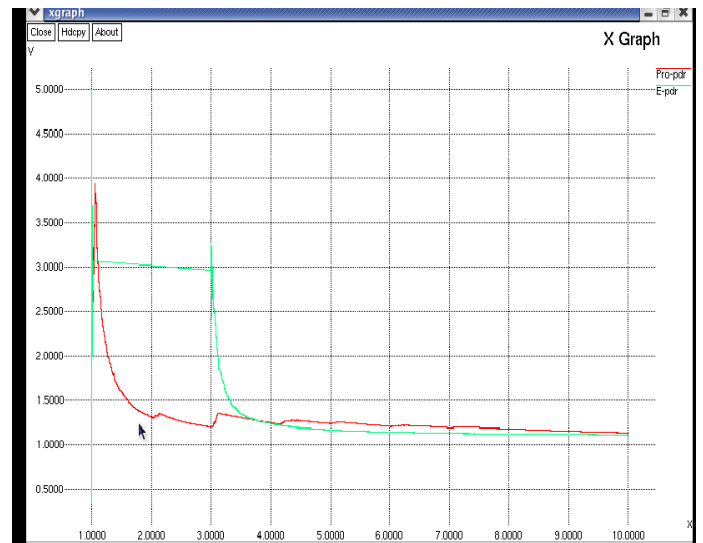

Fig 3: Graph of packet drop ratio

We can see in WiMAX, pdr is minimum from starting only. Due to high speed of WiMAX packet drop ratio decreases. Opposite to it ,pdr is very large in Wi-Fi compared to WiMAX. Pdr comes in control at the end in Wi-Fi. Retransmission and all also occurs in Wi-Fi but due to slow speed, pdr is more in it.

VIII. RELATED WORK

In the Wi-Fi transmission process, we transmit the video from media sever, but at a client side we have seen that some of the packets were lost. The packet loss is more in Wi-Fi case due to low speed compared to WiMAX, ultimately video quality achieved is not so good.

In our case we are using RTP protocol with WiMAX technology.RTP gives functionality like resequencing of packets at application layer and recovering lost segments etc and WiMAX gives us high speed transmission so as a result we achieve great video quality.

So, we have implemented protocol in ns-2 which improves quality of video transmitted from server. All the drawbacks of Wi-Fi system were overcome successfully.

IX. CONCLUSION

Thus we presented an NS-2 based IEEE 802.16 network emulator for supporting streaming video services. Details of the implementation of the emulation in NS-2, including time synchronization, route coexistence problems were addressed. Solutions were then proposed to hook up a video sender to a ns-2 emulator and transmit video over this emulated network to remote client. The proposed emulator can emulate different channels and real propagation conditions. The video is displayed on client side and allows for evaluation of application-level video streaming metrics. This emulator can inject real traffic and can be used as a useful tool to test and develop new algorithms without using high-cost architectures. The performance of the proposed emulator was evaluated when real-time services are taken into account.

Wi-Fi and WiMAX transmission are also compared through this overall transmission of video from server. Finally we have Shown that if WiMax technology is used rather than Wi-Fi, we got more reliability and good network performance overall.

ACKNOWLEDGMENT

We would like to sincerely thank Mr. Amit Zore, our mentor (Lecturer, MMIT, Lohgaon), for his support and encouragement.

REFERENCES

- [1] The Network Simulator: ns-2. Available: <http://www.isi.edu/nsnam/ns>
- [2] WiMAX Forum System Level Simulator. Available: <http://www.wimaxforum.org/home/>
- [3] WiMAX system evaluation methodology, WiMAX Forum, 2007.
- [4] Tutorial for the Network Simulator "ns".
- [5] A. Ganz, Z. Ganz, and K. Wongthavarawat, "Multimedia wireless networks: Technologies, standards, and QoS.
- [6] "Protocol overview: RTP and RTCP" by Tommi Koistinen
- [7] Installation of patch in ns-2. Available: http://www.lrc.ic.unicamp.br/wimax_ns2/
- [8] "WiMAX – Broadband Wireless Access" by Ahmed Younus Technical University of Munich, Germany ahmed.younus@myTUM.de
- [9] "An Introduction to NS, Nam and OTcl Scripting" National University of Ireland, Maynooth Maynooth, Co. Kildare, Ireland.
- [10] <http://www.cubinlab.ee.unimelb.edu.au/~jrid/Docs/Manual-NS2/node320.html>.
- [11] <http://renukabalasubramanian.wordpress.com/> for installation of NS2.
- [12] "<http://140.116.164.80/~smallko/ns2/myevalvid2.rar>" Evalvid software for input to emulator.
- [13] <http://mohittahiliani.blogspot.in>.
- [14] http://ieeexplore.ieee.org/xpl/login.jsp?tp=&arnumber=5560159&url=http%3A%2F%2Fieeexplore.ieee.org%2Fxppls%2Fabs_all.jsp%3Farnumber%3D5560159.
- [15] <http://www.isi.edu/nsnam/ns/doc/node387.html>.
- [16] <http://www.wimaxforum.org/>
- [17] <http://www.radio-electronics.com/info/wireless/wimax/network-architecture.php>.