

# Influence of $\text{Na}_2\text{CO}_3$ , $\text{NaHCO}_3$ and Organic Substances (Algae) in Water on Physical Properties of Blended Pozzolonic Portland Cement

L. Venu Gopal Reddy  
M.Tech (Scholar),  
Structural Engineering  
Malla Reddy Engineering College  
(Autonomous)  
Hyderabad, Telangana, India

B. Vamsi Krishna  
Assistant Professor  
Ms, Structural Engineering  
Malla Reddy Engineering College  
(Autonomous)  
Hyderabad, Telangana, India

**Abstract**— This study is aimed at investigating the effect of strong alkalines in water on compressive strength of admixture cements. The admixture cement cubes were cast with deionised water and deionised water containing the strong alkalines of  $\text{Na}_2\text{CO}_3$  and  $\text{NaHCO}_3$ . In the present study, the effect of strong alkalines such as Carbonates and Bicarbonates of Sodium on setting time and strength development is assessed under the laboratory condition. The results shows  $\text{Na}_2\text{CO}_3$  in deionised water accelerate the initial and final setting times where as the other substance  $\text{NaHCO}_3$  retards the initial and final setting times in all the concentrations. Both  $\text{Na}_2\text{CO}_3$  and  $\text{NaHCO}_3$  in deionised water increase the strength at early age (3-day and 7-day) and decrease significantly at 28-day, 60-day and 90-day. In the present work analysis, the hydration characteristics of the admixture cements using the techniques of X-ray Diffraction analysis and useful conclusions are obtained regarding the influence of strong acids.

**Key words:** strong alkalines (Carbonates and Bicarbonates of Sodium) and Biological Substances (Algae), (Pozzolana Portland Cement + 10% Silica Fume), Water, Compressive Strength, Setting Time, X-Ray Diffraction, best fit curve.

## I. INTRODUCTION

The impurities in water play a major role in application of concrete. In the present study, the effect of strong alkalines (Carbonates and Bicarbonates of Sodium) and biological substances (Algae) on setting time and compressive strength of natural admixture cement is assessed under laboratory conditions. The research programme included tests of soundness, setting times and compressive strength of short term and long term. In this research, the admixture cement cubes were cast with deionised water and deionised water containing the strong alkalines ( $\text{Na}_2\text{CO}_3$  and  $\text{NaHCO}_3$ ). Using cubes of specimens of 50cm<sup>2</sup> face areas and mix ratio 1:3 by weight, 10% silica fume was added by weight. The quantities of cement, silica fume, standard sand and mixing water for each cube are 180gm, 20gm, 600gm and (P/4 +3). Where P is percentage of water required to produce a paste of standard consistency (IS 269-1976). As the experimental results shows that  $\text{Na}_2\text{CO}_3$  in deionised water accelerates the initial and final

setting times where as the other substance  $\text{NaHCO}_3$  retards the initial and final setting times. Both  $\text{Na}_2\text{CO}_3$  and  $\text{NaHCO}_3$  in deionised water increase the strength at early age (3-day and 7-day) and decrease significantly at 28-day, 60-day and 90-day. The biological substances (Algae) in deionised water accelerate both initial and final setting times. Algae in deionised water upto 915cells/mL there is a nominal change in compressive strength at early age (3-day). Beyond 915cells/mL there is a significant change in the compressive strength at early ages as well as long term 28-day, 60-day and 90-day. Comparison of the strong alkaline and biological substances with those of control mix levels that both carbonates and algae decrease the compressive strength. The rate of decrease in compressive strength is with increase in concentration. The present work analyses the hydration characteristics of admixture cements using X-ray diffraction (XRD) and useful conclusions are obtained regarding the influence of alkaline and biological substances.

## I. OBJECTIVES:

- To examine the typical compounds responsible for such changes in setting times and compressive strength development of cement mortars through X-Ray diffraction analysis.
- To build up best-fit curve and to formulate the mathematical equation for assessing the significant change in initial, final setting times and compressive strength.
- To study effect of water quality on initial and final setting times, soundness of cement and short term compressive strength development of cement mortar.
- To plan possible chemical reactions that takes place in hydration of natural admixture cement with chemical or biological substances in deionised water.

## II. SCOPE OF THE WORK

- To assess the effect of individual substances like  $\text{Na}_2\text{CO}_3$ ,  $\text{NaHCO}_3$  and Algae with different

concentrations in mixing water on initial and final setting times of cement.

- To study the effect of each of these individual substances with varying concentrations in mixing water on the soundness of cement.
- To examine the effects of these substances with different concentrations in deionised water as mixing water (in mortar cubes) on short term and long-term Strength development of cement mortars.
- To conduct X-ray diffraction analysis of hydrated cement products, associate compounds and other compounds to draw meaningful conclusions on setting times and strength development of cement.
- To develop mathematical relationships between the substances in mixing at versus setting times and versus strength development of cement mortar and chemical reactions on hydration.

#### IV. MATERIALS AND METHODS

Table 4.1: Percentage Composition of the Major Compounds Present in the Test Cement

Sl. No.	Name of the Compound	Conversion Formula	% Present in Cement
1	Tricalcium silicate (3CaO. SiO <sub>2</sub> )	4.07 (CaO) -7.60 (SiO <sub>2</sub> ) -6.72 (Al <sub>2</sub> O <sub>3</sub> )-1.43 (Fe <sub>2</sub> O <sub>3</sub> )-2.85 (SO <sub>3</sub> )	51.49
2	Dicalcium silicate (2CaO.SiO <sub>2</sub> )	2.87 (SiO <sub>2</sub> ) -0.754(3CaO.SiO <sub>2</sub> )	23.37
3	Tricalcium aluminate (3 CaO.Al <sub>2</sub> O <sub>3</sub> )	2.65 (Al <sub>2</sub> O <sub>3</sub> ) -1.69 (Fe <sub>2</sub> O <sub>3</sub> )	9.31
4	Tetracalcium aluminoferrite (4CaO.Al <sub>2</sub> O <sub>3</sub> .Fe <sub>2</sub> O <sub>3</sub> )	3.04 (Fe <sub>2</sub> O <sub>3</sub> )	11.7

Table 4.2: Physical Properties of PPC

Sl. No.	Property	Result	IS 1489(part-1)-1991
1	Specific Surface(m <sup>2</sup> /kg)	370	Not less than 300
2	Normal consistency	35%	Not specified
3	Setting times (minutes)		
	a) Initial	105	Not less than 30
	b) Final	195	Not less than 600
4	Compressive strength (MPa)		
	a) 3 day	24.4	Not less than 16
	b) 7 day	37.3	Not less than 22
	c) 28 day	48.9	Not less than 33

Table 4.3: Chemical Properties of PPC

Sl. No.	Chemical requirement	Test results	Requirements of IS 1489(part-1) -1991
1	Magnesia (% by mass)	1.2	Not more than 6.0%
2	Sulphur trioxide(% by mass)	2.3	3
3	Sulphide sulphur	0.26	1.5
4	Total loss on ignition	2.2	Not more than 5.0%
5	Insoluble residue	24.5	[X+4.09100-X0/100] Max. X is %Pozzolana in PPC
6	Chloride	0.022	0.1

Table 4.4: Properties of Sand

Sl. No.	Properties	Unit	Results
1	Specific gravity	-	2.64
2	Bulk density	kN/m <sup>3</sup>	15.54
3	Fineness modulus before sieving	-	2.72
4	Particle size variation	mm	0.15 to 2.0
5	Loss of weight with concentrated Hydrochloric acid	%	0.124

Table 4.5: Characteristics of water (All values in mg/L except pH)

Sl. No.	Parameter	Concentration
1	pH	6.8
2	Total dissolved solids	400
3	Alkalinity	120
4	Acidity	12
5	Hardness	140
6	Sulphates	20
7	Chlorides	65

Table 4.6: Properties of Silica fume

Sl. No.	Parameter	Specification	Analysis
1	SiO <sub>2</sub>	% Min 85.0	89.2
2	Moisture content	% Max 3.0	0.4
3	Loss on ignition	% Max 6.0	2.2
4	45 micron	% Max 10	8
5	Bulk density	500-700 Kg/m <sup>3</sup>	0.55

## V. TEST PROGRAMME

Table 5.1: Details of Test Programme

The details of the mineral and chemical admixtures used in the experimental work are presented in Table 4.16. A total of 60 samples of standard mould used in Vicat's apparatus were cast and tested for initial and final setting time's experiments. The same number of samples of standard mould was used in Le-chatelier's equipment to test for soundness. A total of 420 mortar cubes of 50 cm<sup>2</sup> cross-sectional area were tested at different ages (3-day, 7-day, 21day, 28-day, 60day and 90-day) for compressive strength. For entire experimental programme altogether 480 samples were casted and tested.

Sl. No	Constituent	No. of specimens for setting times test	No. of specimens for soundness test	No. of specimens for compression test	Total
1	PPC	3	3	3 × 6	24
2	PPC+10%SF	3	3	3 × 6	24
3	PPC+10%SF+ 1gm/l Na <sub>2</sub> CO <sub>3</sub>	3	3	3 × 6	24
4	PPC+10%SF+ 2gm/l Na <sub>2</sub> CO <sub>3</sub>	3	3	3 × 6	24
5	PPC+10%SF+ 4gm/l Na <sub>2</sub> CO <sub>3</sub>	3	3	3 × 6	24
6	PPC+10%SF+ 10gm/l Na <sub>2</sub> CO <sub>3</sub>	3	3	3 × 6	24
7	PPC+10%SF+ 20gm/l Na <sub>2</sub> CO <sub>3</sub>	3	3	3 × 6	24
8	PPC+10%SF+ 1gm/l NaHCO <sub>3</sub>	3	3	3 × 6	24
9	PPC+10%SF+ 2gm/l NaHCO <sub>3</sub>	3	3	3 × 6	24
10	PPC+10%SF+ 4gm/l NaHCO <sub>3</sub>	3	3	3 × 6	24
11	PPC+SF+ 10gm/l NaHCO <sub>3</sub>	3	3	3 × 6	24
12	PPC+10%SF+ 20gm/l NaHCO <sub>3</sub>	3	3	3 × 6	24
13	PPC+10%SF+ Algae435Cells /ml	3	3	3 × 6	24
14	PPC+10%SF+ Algae915Cells /ml	3	3	3 × 6	24
15	PPC+10%SF+ Algae1130Cell s/ml	3	3	3 × 6	24
16	PPC+10%SF+ Algae1570Cell s/ml	3	3	3 × 6	24
	<b>TOTAL</b>	<b>48</b>	<b>48</b>	<b>288</b>	<b>384</b>

Note: SF = Silica fume, PPC = Portland Pozzolana Cement,

## VI. EXPERIMENTAL PROCEDURE

### 6.1 Compressive Strength

Moulds for the cube specimens of 50 cm<sup>2</sup> face area, are of metal not amendable, and don't stick to cement mortar. The sides of the mould are sufficient thick, to prevent spreading and wrapping. The moulds are rigidly constructed in such a manner that the removal of the moulded specimen can be easily without damage. The moulds are machined so that when assembled, the dimensions and the internal faces will be as per required specifications.

During summer, when the temperature was high, the temperature and humidity were controlled by conducting the experiments in an air-conditioned room. Some experiments were conducted during the night time to maintain the controlled conditions. The temperature and humidity were checked in the room by using thermometer and hygrometer respectively. Since normal consistency, initial and final setting times, soundness and compressive strength of cement are sensitive to temperature and humidity, more or less 27°C temperature and 60% humidity were maintained throughout the experimental work.

### 6.2 X-Ray Diffraction

The X-ray diffraction techniques employed for cement provide (i) analytically - for the identification of unknown compounds and sometimes-quantitative estimation of the phases present in mixtures and (ii) structurally - to give information about the composition of individual compounds (Taylor, 1964).

X-rays, which are electromagnetic radiation with wavelengths of about 100 pm (picometer –  $10^{-12}$  m), may be produced by bombarding a metal with high-energy electrons. The electrons decelerate as they plunge into the metal and generate radiation with a continuous range of wavelengths called Bremsstrahlung (Bremse is German for brake, Strahlung for ray). Superimposed on the continuum are a few high-intensity, sharp peaks. These peaks arise from collisions of the incoming electrons with the electrons in the inner shells of the atoms. A collision expels an electron from an inner shell, and an electron of higher energy drops into the vacancy, emitting the excess energy as an X-ray photon called characteristic or monochromatic radiation (Warren, 1980).

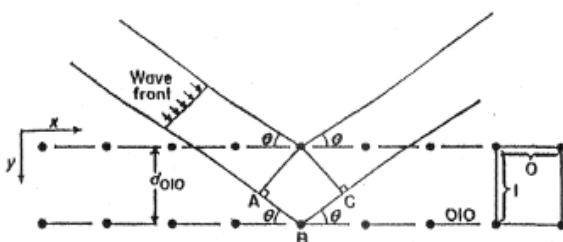

Fig.1: A two – dimensional representation of a lattice.

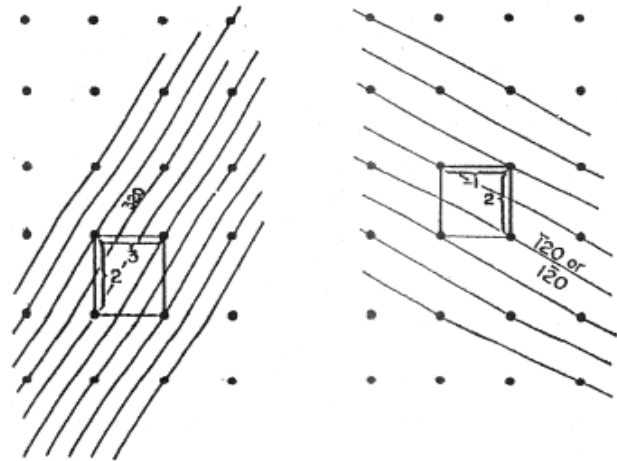

Fig. 2: Two – dimensional representation of a lattice, showing conditions for reflection and the method of defining planes.

## VII. RESULTS AND DISCUSSION

The results of the present investigation are presented both in tabular and graphical forms. In order to facilitate the analysis, interpretation of the results is carried out at each phase of the experimental work. This interpretation of the results obtained is based on the current knowledge available in the literature as well as on the nature of result obtained. The significance of the result is assessed with reference to the standards specified by the relevant I S codes

1. The averages of both the initial and final setting times of three cement samples prepared with mixing water containing typical chemical or biological component of varying concentrations under consideration are compared with those of the cement specimens prepared with deionised water. If the difference is less than 30 minutes, the change is considered to be negligible or insignificant and if it is more than 30 minutes, the change is considered to be significant.

2. The average compressive strength of at least three cubes prepared with water under consideration is compared with that of three similar cubes prepared with deionised water. If the difference in the strength is less than 10%, it is considered to be insignificant and if it is greater than 10%, it is considered to be significant.

3. The average soundness test results of three samples prepared with mixing water under consideration are compared with those with deionised water. The unsoundness of the specific sample, made with mixing water of particular concentration, is significant if the result of Le-Chatelier's test is more than 10 mm.

Test results of initial and final setting times, soundness and percent change in compressive strengths of the test blocks made with different mixing water samples and deionised water are reported

Though all the samples made with different test solutions either accelerate or retard significantly the setting process at high concentrations of different compounds in deionised mixing water, the limits for significance criteria in setting times of all these samples under consideration are within the range of standards specified in IS 8112-1989. The IS code prescribed that initial setting time should not be less than 30

minutes and final setting time should not be more than 600 minutes.

Soundness test results of all the samples made with different concentration of test solutions of various compounds are presented in the Tables 5.1 to 5.5. The IS 269 -1976 Code specifies the limit for soundness that the Le-Chatelier's test result should not be more than 10 mm for ordinary Portland

cements. The Le-Chatelier's test results of soundness of all substances vary proportionately the concentration of the substance. But this increase in variation is very meager and less than the significant value, i.e., 10 mm and hence there is no appreciable change in volume of the samples. All the samples made with different test solutions of various concentrations are sound

Table 7.1. Initial and final setting times, Soundness of cement and compressive strength of admixture cement (PPC+10% Silica Fume) mortar cubes of various concentration of Alkaline Substances at different ages.

S. No	Water Samples	Initial setting	Final setting	Soundness in mm	Compressive Strength in N/mm <sup>2</sup>					
					3day	7day	21day	28day	60day	90day
I	Deionised Water	128	347	0.5	25	37	42	47	52	54
	Alkaliene Substances (i)Na <sub>2</sub> CO <sub>3</sub> g/L									
	1	128	337	1.0	30	42	43.5	47.5	45	36
	2	109	318	2.5	25	37	41	47	51	54
	4	98	304	3.5	20	36	38	46	48	53
	10	80	291	4.0	35	42	46	52	48	54
	20	69	278	4.5	34	41	43	44	41	48
	(ii)NaHCO <sub>3</sub> g/L									
	1	128	343	1.5	36	44	48	55	56	51
	2	134	371	2.0	36	44	46	46	48	50
	4	147	386	2.5	35	40	44	54	52	48
	10	185	401	3.0	34	43	44.5	46	48	48.5
	20	213	413	4.0	35	41	43	45	46	47

Table 7.2 Initial and final setting times, Soundness of cement and Percentage variation of compressive strength of admixture cement (PPC+10% Silica Fume) mortar cubes of various concentration of Alkaline Substances at different ages.

S. No	Water Samples	Initial setting	Final setting	Soundness in mm	Compressive Strength in N/mm <sup>2</sup>					
					3day	7day	21day	28day	60day	90day
I	Deionised Water	128	347	0.5	0	0	0	0	0	0
	Alkaliene Substances (i)Na <sub>2</sub> CO <sub>3</sub> g/L									
	1	128	337	1.0	20	13.57	3.57	-2.13	-13.46	-33.33
	2	109	318	2.5	0.0	0.0	-2.38	0.0	-1.96	0.0
	4	98	304	3.5	20	0.0	9.52	-2.13	-7.70	-1.85
	10	80	291	4.0	40	13.51	9.52	10.64	-7.69	0.00
	20	69	278	4.5	36	10.81	2.38	-4.26	-11.53	-17.96
	(ii)NaHCO <sub>3</sub> g/L									
	1	128	343	1.5	44	18.91	14.28	17.02	7.96	-5.55
	2	134	371	2.0	44	18.91	9.52	-2.17	-7.69	-7.41
	4	147	386	2.5	40	8.10	4.76	14.89	0.0	-11.11
	10	185	401	3.0	36	16.22	5.95	-2.13	-7.69	-10.18
	20	213	413	4.0	40	10.81	2.38	-4.26	-11.53	-12.96

Table 7.3. Initial and final setting times, Soundness of cement and compressive strength of admixture cement (PPC+10% Silica Fume) mortar cubes of various concentration of Biological Substances at different ages.

S. No	Water Samples	Initial setting	Final setting	Soundness in mm	Compressive Strength in N/mm <sup>2</sup>					
					3day	7day	21day	28day	60day	90day
I	Deionised Water	128	347	0.5	25	37	42	47	52	54
	<b>Biological Substances, Algae Cells/mL</b>									
	435	140	285	1.0	23	28	32	36	37	38
	915	132	270	1.5	21	26	28	33	36	38
	1130	112	256	2.0	19	25	28	33	34	38
	1570	98	235	2.5	18	25	27	31	32	36

Table 7.4: Initial and final setting times, Soundness of cement and Percentage variation of compressive strength of admixture cement (PPC+10% Silica Fume) mortar cubes of various concentration of Biological Substances at different ages.

S. No	Water Samples	Initial setting	Final setting	Soundness in mm	Percent Change in Compressive Strength					
					3day	7day	21day	28day	60day	90day
I	Deionised Water	128	347	0.5	0	0	0	0	0	0
V	<b>Biological Substances, Algae Cells/mL</b>									
	435	140	285	1.0	-8	-24.32	-23.80	-23.40	-28.84	-29.62
	915	132	270	1.5	-16	-29.72	-33.33	-29.78	-30.77	-29.62
	1130	112	256	2.0	-24.0	-32.43	-33.33	-29.78	-34.61	-29.62
	1570	98	235	2.5	-28	-32.43	-35.71	-34.04	-38.46	-33.35

### CONCLUSIONS

- Based on the results obtained in the present investigation Presence of Na<sub>2</sub>CO<sub>3</sub> in water in concentrations more than 4 g/L and 10 g/L accelerates significantly, the initial and final setting respectively. Further, a concentration higher than 10 g/L results in significant decrease in compressive strength.
- Presence of NaHCO<sub>3</sub> in concentrations more than 10 g/L retards significantly the initial and final setting respectively. Further, a concentration higher than 10 g/L results in significant decrease in compressive strength.
- Strong alkaline substances under consideration (Na<sub>2</sub>CO<sub>3</sub> and NaHCO<sub>3</sub>) in water reduce the compressive strength significantly right from the early age, thus requiring caution in the use of wafer containing these substances.
- Presence of algae in water accelerates significantly the initial and final setting in concentrations more than 1130 cells/mL. Their concentration is more than 915 cells/mL results in significant decrease in compressive strength.



## SCOPE FOR FURTHER STUDY

- The following aspects can be taken up for further investigation.
- Similar studies can be carried out on admixture cement concrete to analyse the effect of various chemical and biological substances on the compressive strength with a special attention on the durability of concrete beyond 2-years.
- The effect of other similar substances present in water, which are not covered in this research, on the setting properties of cement and strength of cement mortar can be investigated.
- The effect of water bodies located at various places containing unique compounds can be studied to develop standards and limitations on the use of such waters in cement construction.
- Similar studies can be carried out on other engineering properties of cement mortar like tensile strength and shear strength.
- Formation of lattice structures of hydrated cement compounds need to be investigated with spiked neutral salts, alkaline and acidic substances by using X-ray diffraction analysis.

## REFERENCES

1. Akroyd, T.N.W. (1962): Concrete Properties and Manufacture, Pergamon Press.
2. Al-Amoudi, O.S.B., (2002): Attack on Plain and Blended Cements Exposed to Aggressive Sulphate Environment, Cement and Concrete Composites, Vol. 24, pp. 305-316.
3. Al-Amoudi, O.S.B., Rasheeduzzafar, Maslehuddin, M. and Abdul Jaawad, S.N. (1994): Performance of Plain and Blended Cements in High Chloride Environments, Durability of Concrete - ACI-SP 145, pp. 539-555.
4. ASTM C 150-78a (1955): Specification for Portland Cement, Philadelphia.
5. Banthia, N. and Sheng, J. (1991): Durability of Carbon Fibre Reinforced Cements in Acidic Environments, ACI-SP 126, pp. 836-850.
6. Basheer, P.A.M., Long, A.E., and Montgomery, F.R. (1994): An Interaction Model for Causes of Deterioration and Permeability of Concrete, ACI-SP, 144, pp. 217-231.
7. IS 2386 (Part I): 1963: Methods of Test for Aggregates for Concrete, Part I - Particle Size and Shape, Indian Standards Institution, New Delhi.
8. IS 2386 (Part I): 1963: Methods of Test for Aggregates for Concrete, Part III - Specific Gravity, Density, Voids, Absorption and Bulking, Indian Standards Institution, New Delhi.
9. IS 456:1978: Code of Practice for Plain and Reinforced Concrete, Indian Standards Institution, New Delhi.
10. IS 456:2000: Code of Practice for Plain and Reinforced Concrete, Indian Standards Institution, New Delhi.
11. IS 516:1959: Methods of Test for Strength of Concrete.
12. IS 5513:1976: Vicat's Apparatus (First Revision), Indian Standards Institution, New Delhi.
13. IS 5514:1969: Apparatus Used in Le-Chatelier Test, Indian Standards Institution, New Delhi.
14. IS 650:1966: Standard Sand for Testing of Cement (First Revision), Indian Standards Institution, New Delhi.
15. IS 8112:1989: Specifications for 43-Grade Ordinary Portland cement, Indian Standards Institution, New Delhi.
16. IS 9103:1999: Concrete Admixtures-Specifications., Bureau of Indian Standards, New Delhi, India.
17. Kaushik, S.K., Kukreja, C.B., Gupta, V.K., Kishore, K. (1988): Standard Publishers and Distributors, Delhi, pp. 7-10, 15-16.
18. Komar, A. (1987): Building Materials and Composites, Mir Publisher, Moscow.
19. Krishna Murthy A.P., Kamasundra Rao, A. and Khandekar, A.A., Concrete Technology, Dhanpath Rai and Sons, Delhi.
20. Krishnamurthy, G.S. (1991): Material Testing Laboratory Manual, S.V.U. College of Engineering, Tirupati, Vol. 2.
21. Locher, F.W. (1985): Research Institute for Cement Industry, Germany.
22. Mehta, P.K. (1983): Mechanism of Sulphate Attack on Portland Cement Concrete - Another Look Cement and Concrete Research, Vol. 13, No. 3, pp. 401-406.
23. Mehta, P.K. (1983): Pozzolanic and Cementitious by Products as Mineral Admixtures for Concrete - A Critical Review, Proceedings of ACI Special Publication, ACI-SP-79, pp. 1-43.
24. Mehta, P.K. (1984): Testing and Correlation of Fly Ash Properties with Respect of Pozzolanic Behaviour. CS-3314, Electrical Power Research Institute (EPRI), Palo Alto California, Jan.
25. Mehta, P.K. (1988): Pozzolanic and Cementitious Bi-products in Concrete- Another Look, ACI-SP-114, Vol. 1, pp. 1-43.
26. Mehta, P.K. (1988): Standard Specification for Mineral Admixtures - An Overview, ACI-SP-91, pp. 637-658.
27. Mehta, P.K. (1991): Durability of Concrete: Fifty Years of Progress, ACI-SP-126, pp. 130.
28. Mehta, P.K. (1993): Sulphate Attack on Concrete - A Critical Review, Material Science of Concrete - III, Edited by J. Skalny, American Ceramic Society, pp. 105-130.
29. Mehta, P.K. (2001): Reducing the Environmental Impact of Concrete, Concrete International, Jan. pp. 61-66.
30. Mehta, P.K. and Montero, P.J.M. (1997): Concrete Micro Structures- Properties and Materials, Indian Concrete Institute, Chennai.
31. Natesan, S.C. (2003): Durability of High Performance Concrete, Proceedings of International Conference on Recent Trends in Concrete Technology and Construction: Coimbatore, India, pp. 493-498.
32. Neville, A. and Brooks, J.J. (2003): Concrete Technology, Pearson Education (Singapore) Pvt. Ltd.
33. Neville, A.M. (1970): Properties of Concrete, The English Language Book Society, Pitman Publishers.