

Investigation of Impact of FACTS Controller in Transmission Line Network

Pravin B.Mali (ME EPS-II)
Department of Electrical Engineering
SSBT's College of Engineering & Technology,
Bambhori, Jalgaon (India-425001)

Nilesh S. Mahajan (Assist. Proff.)
Department of Electrical Engineering
SSBT's College of Engineering & Technology,
Bambhori, Jalgaon (India-425001)

Abstract- In an existing transmission line power quality, reliability of transmission and control of power flow is key issue in recent power system area. With the rapid increase of electric power demand, power system networks have been operated under highly stressed conditions and the capacity of power transfer has been severely limited. In order to improve the power system stability and to solve the issues like reactive power planning problems, a flexible alternating current transmission systems (FACTS) are widely used by power system utilities. The various FACTS devices such as static var compensator (SVC), static synchronous compensator (STATCOM), UPFC, UPQC, IPFC, DVR and TCSC, etc are used.

The main role of FACTS devices is to control the network condition in a very fast manner, the transmission voltage and power flow. This paper shows the effect of FACTS devices in transmission line, the simulation results are carried out and stated in Matlab-simulink. With the help of simulation, this paper shows that without any FACTS device, the system is unstable. However, it becomes stable when FACTS controllers are connected. This clearly shows that the inclusion of FACTS controllers into power systems maintains the stability of the power system when the system load-ability is increased.

Keywords- FACTS, Power quality, PI Controller, SVPWM, STATCOM.

I. INTRODUCTION

An increasingly competitive market where economic and environmental pressures limit their scope to expand transmission facilities. The optimization of transmission corridors for power transfer has become a great importance. In this scenario, the FACTS technology is a smart option for increasing system operation flexibility. FACTS devices control the consistent parameters that manage the operation of a transmission system, thus enabling the line to carry power close to its thermal rating. It has been observed that shunt FACTS devices give maximum benefit from their stabilized voltage support when positioned at the optimal place of the transmission line [1-3].

In order to improve the power system stability and to solve the issues like reactive power planning troubles, flexible alternating current transmission systems (FACTS) are widely used by power system utilities. The various FACTS devices such as static var compensator (SVC), static synchronous compensator (STATCOM), UPFC, UPQC, IPFC, DVR and TCSC, etc are used [2]. FACTS devices are very effective and capable of increasing the power transfer capability of a line, if the thermal limit permits, while maintaining the same degree of stability.

The relatively recent development and use of FACTS family controllers static synchronous compensator (STATCOM) in power transmission systems has led to many applications of these controllers to can improvement smooth and rapid reactive power [3] compensation to power systems, and therefore can be used to give voltage support, increase transient stability and recover damping of power system.

II. TROUBLES IN POWER TRANSMISSION

FACTS technology is group of high power electronic controllers, which can be applied independently or in bringing together with others to control one or more of the unified system parameters [4]. The thyristor or high-power transistor is the basic element for a range of high-power electronic Controllers. FACTS technology provides the opportunity to,

- (i) Increase loading capacity of transmission lines.
- (ii) Avoid blackouts.
- (iii) Improve generation productivity.
- (iv) Reduce circulating reactive power.
- (v) Improves system stability limit.
- (vi) Reduce voltage flicker.
- (vii) Reduce system damping and oscillations.
- (viii) Control power flow so that it flows through the selected routes.
- (ix) blockage management

III. FUNDAMENTAL OF FACTS CONTROLLER

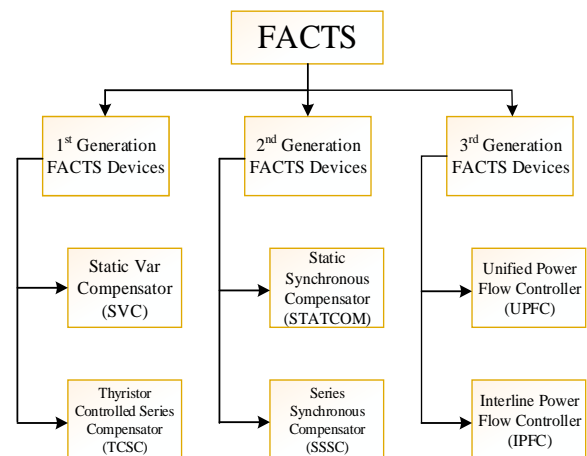

Fig. 1: Block diagram of FACTS Controller

Fig. 1 shows the various FACTS controller for electrical power system. The Static Synchronous Compensator (STATCOM) is one of the Flexible AC Transmission Systems (FACTS) devices with capable prospect of applications [5]. There are two basic controls which can be applied in the STATCOM. One is the control of the DC voltage across the DC capacitor inside the STATCOM and another is the AC voltage regulation of the power system at the bus bar where the STATCOM is installed. AC voltage regulation is comprehended by controlling the reactive power exchange between the STATCOM and a power system. Pulse width modulation (PWM) [6] is used for loss consideration in converters. The DC voltage across the DC capacitor must be constant if the STATCOM converter works on Pulse Width Modulation (PWM) algorithm.

A typical V-I characteristic of a STATCOM is depicted in Fig. 2. As can be seen, the STATCOM can supply both the capacitive and the inductive compensation and is able to autonomously control its output current over the rated maximum capacitive or inductive range irrespective of the amount of ac-system voltage [7]. That is, the STATCOM can provide full capacitive-reactive power at any system voltage even as low as 0.15pu.

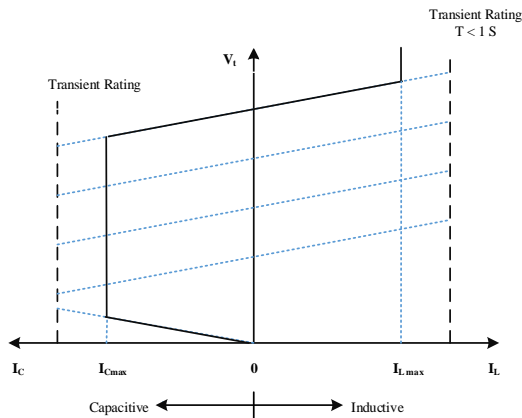

Fig. 2: V-I Characteristics of STATCOM

A) *Need for Power System Stability:* Concern with stability limits the transfer capability of the system, there is a need to ensure stability and reliability of the power system due to cost-effective reasons. The power system industries are the sources where the continuous changes going to occur to unbalance the system [2]. Number of users (load) increases leads to increase in power demand. Power systems are comprehensive as they become interconnected.

B) *Shunt and Series Facts Devices for Power System Stability:*

1. STATCOM

STATCOM is a shunt connected device, which controls the voltage at the connected bus to the reference value by adjusting voltage and angle of internal voltage source. STATCOM is the Voltage-Source Inverter (VSI), which converts a DC input voltage into AC output voltage in order to compensate the active and reactive power required by the system. STATCOM exhibits steady current characteristics when the voltage is low/high under/over the limit. This allows STATCOM to deliver steady reactive power at the limits compared to SVC. [1-2]. One of the

many devices under the FACTS family, a STATCOM is a regulating device which can be used to regulate the flow of reactive power in the system self-regulating of other system parameters. STATCOM has no long term energy support on the dc side and it cannot switch over real power with the ac system. In the transmission systems[10], STATCOMs first and foremost handle only fundamental reactive power switch over and provide voltage support to buses by modulating bus voltages during dynamic disturbances in order to provide better transient characteristics, improve the transient stability margins and to damp out the system oscillations due to these disturbances.

2. TCSC

A TCSC is a capacitive reactance compensator, which consists of a series capacitor bank shunted by a thyristor controlled reactor in order to provide a smoothly variable series capacitive reactance. TCSC is the type of series compensator. The structure of TCSC is capacitive bank and the thyristor controlled inductive supply connected in parallel. The theory of TCSC is to compensate the transmission line in order to adjust the line impedance, increase load ability, and avoid the voltage collapse[10]. The feature of the TCSC depends on the comparative reactance of the capacitor bank and thyristor branch. Even through a TCSC in the ordinary operating range in mainly capacitive, but it can also be used in an inductive mode. The power flow over a transmission line can be increased by controlled series compensation with least amount risk of sub synchronous resonance (SSR). TCSC is a second generation FACTS controller, which controls the impedance of the line in which it is connected by changeable the firing angle of the thyristors. A TCSC unit comprises a series fixed capacitor that is connected in parallel to a thyristor controlled reactor (TCR). A TCR includes a pair of anti-parallel thyristors that are connected in series with an inductor. In a TCSC, a metal oxide varistor (MOV) by the side of with a bypass breaker is connected in parallel to the fixed capacitor for overvoltage protection. A whole compensation system may be made up of several of these modules.

IV. SYSTEM MODELLING

Fig. 3 shows the Control Strategy of STATCOM illustration of three phase three wire distribution system with unbalanced and nonlinear load and the STATCOM with space vector pulse width modulation controller.

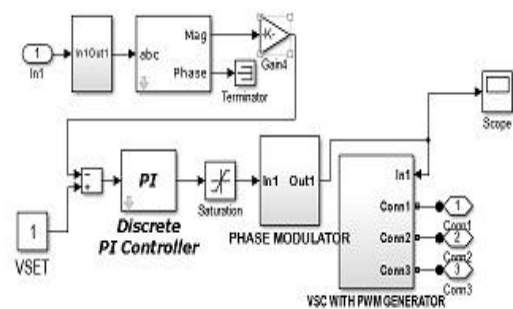

Fig 3: Control Strategy of STATCOM

The STATCOM consists of a three-phase pulse width modulated (PWM) voltage-source converter (VSC) [8-9] using insulated-gate bipolar transistors (IGBTs), three interface inductors and dc capacitor. The STATCOM injects currents into the point of common coupling in such a way so as to keep up balancing and harmonic elimination in the source currents. The VSI operation is supported by the dc storage capacitor with voltage across it.

The system terminal voltages are given as,

$$V_a = V_m \sin(\omega t) \tag{1}$$

$$V_b = V_m \sin(\omega t) - \frac{2\pi}{3} \tag{2}$$

$$V_c = V_m \sin(\omega t) + \frac{2\pi}{3} \tag{3}$$

Where V_m and ω are the peak amplitude and angular frequency, respectively, of the system voltage at the PCC. The amplitude of PCC voltage is calculated as,

$$V_t = \sqrt{\frac{2}{3} (V_a^2 + V_b^2 + V_c^2)} \tag{4}$$

A) Control of VSC based STATCOM: The VSC is designed for compensating a reactive power. There are lots of control schemes are available for control of shunt active compensators [9] such as instantaneous reactive power theory, power balance theory, synchronous reference frame theory, symmetrical components based etc. and the synchronous reference frame theory is used for the control of proposed STATCOM. The load currents and the point of common coupling (PCC) [10] voltages and dc bus voltage of STATCOM are sensed as feedback signals to form a closed loop system. The load currents from the a-b-c frame are first converted to the a-b-c frame and then to the d-q-o frame as,

$$\begin{bmatrix} I_{Ld} \\ I_{Lq} \\ I_{Lo} \end{bmatrix} = \frac{2}{3} \begin{bmatrix} \cos\theta & -\sin\theta & \frac{1}{2} \\ \cos\left(\theta - \frac{2\pi}{3}\right) & -\sin\left(\theta - \frac{2\pi}{3}\right) & \frac{1}{2} \\ \cos\left(\theta + \frac{2\pi}{3}\right) & \sin\left(\theta + \frac{2\pi}{3}\right) & \frac{1}{2} \end{bmatrix} \begin{bmatrix} I_{La} \\ I_{Lb} \\ I_{Lc} \end{bmatrix}$$

Where, $\cos\theta$, $\sin\theta$ are obtained using a three-phase PLL. The d-axis and q-axis currents consist of fundamental and harmonic components as,

$$I_{Ld} = I_{d\ dc} + I_{d\ ac} \tag{5}$$

$$I_{Lq} = I_{q\ dc} + I_{q\ ac} \tag{6}$$

B) PQ Theory: Using the definition of the instantaneous reactive power theory for a balanced three phase three wire system, the quadrature component of the voltage is always zero, the real (p) and the reactive power (q) [11-12] injected into the system by the STATCOM can be expressed under the d-q reference frame as,

$$p = V_d I_d + V_q I_q \tag{7}$$

$$q = V_q I_d - V_d I_q \tag{8}$$

Since $V_q=0$, I_d and I_q completely describe the instantaneous value of real and reactive powers produced by the STATCOM when the system voltage remains constant. Therefore the instantaneous three phase current measured is transformed by abc to_dqo transformation. The main advantage of this scheme is that it incorporates a self-supporting dc bus.

V. SIMULATION RESULTS

To verify the proposed control method, digital simulation using MATLAB-SIMULINK has been carried out. The space vector PWM based self-tuned PI controller is used to generate gate pulses for each leg of voltage source converter of STATCOM.

Sr no	TOTAL GENERATION	RESULTS	
		REAL POWER [p.u.]	REACTIVE POWER [p.u.]
1	STATCOM	16.5582	26.5901
2	TCSC	15.8081	26.5901

Fig.20 Result Analysis of Statcom and Tcsc Fact controller

X. CONCLUSION

Using MATLAB-SIMULINK the proposed control method is verified and results are carried out. With the help of simulation, this paper shows that without any FACTS device, the system is unstable. However, it becomes stable when FACTS controllers are connected. This clearly shows that the addition of FACTS controllers (STATCOM) into power systems maintains the stability of the power system when the system load-ability is increased. as compare to TCSC Facts Controller.

REFERENCES

- [1] Dipti Mohanty, Aziz Ahamad and M. A. Khan, "Modelling, Simulation and Performance Analysis of FACTS Controller in Transmission line", *International Journal of Emerging Technology and Advanced Engineering*, ISSN 2250-2459, Volume 3, Issue 5, May 2013.
- [2] B. T. Ramakrishna Rao P. Chanti, N. Lavanya, S. chandra Sekhar, Y. Mohan kumar, "Power System Stability Enhancement Using Fact Devices", *International Journal of Engineering Research and Applications*, ISSN : 2248-9622, Vol. 4, Issue 4(Version 1), April 2014, pp.339-344.
- [3] Jianye Chen, ShanSong, ZANJI Wang, "Analysis and Implement of Thyristor-based STATCOM", *International Conference on Power System Technology*, 2006.
- [4] Engr. Qazi Waqar Ali , Prof. Dr. Azzam ul Asar, "Smart Power Transmission System Using FACTS Device", *International Journal of Engineering & Computer Science IJECS-IJENS* Vol:12 No:06. December-2012.
- [5] Ms. Chitra Thakur and Mr. Saurabh Sahu, "Analysis Of Voltage Stability And Transfer Capability Enhancement Of Transmission System Using Facts Controllers", *Current Trends in Technology and Science* ISSN : 2279-0535. Volume : II, Issue : VI, 2013.
- [6] Raju Pandey and A. K. Kori, "Enhancement of Power Quality in Transmission Line Using Flexible Ac Transmission System", *International Journal of Science, Engineering and Technology Research(IJSETR)* Volume 2, Issue 8, August 2013.

- [7] Arvind Pahade and Nitin Saxena, "Transient stability improvement by using shunt FACT device (STATCOM) with Reference Voltage Compensation (RVC) control scheme", *International Journal of Electrical, Electronics ISSN No. (Online) : 2277-2626 and Computer Engineering 2(1): 7- 12(2013)*.
- [8] A. B. ARSOY, Y. LIU, P. F. RIBEIRO, & F. WANG, "Static-Synchronous Compensators And Superconducting Magnetic Energy Storage Systems In Controlling Power System Dynamics", *IEEE Industry Applications Magazine*, Mar-Apr 2003.
- [9] Impact of TCSC on the Protection of Transmission Lines Mojtaba Khederzadeh and Tarlochan S. Sidhu, *Fellow, IEEE Ieee Transactions On Power Delivery*, Vol. 21, No. 1, January 2006
- [10] S.K.Das and J.K.Moharana, "Design, Analysis and Simulation of SmallSignal Control Strategy of a STATCOM for Reactive Power Compensation on Variation of DC link Voltage", *International Conference on Power, Energy and Control (ICPEC)*, 2013.
- [11] Luis M. Castro, Enrique Acha, and Claudio R. Fuerte-Esquivel, "A Novel STATCOM Model for Dynamic Power System Simulations", *IEEE Transactions On Power Systems*, Vol. 28, No. 3, August 2013.