

Log – Periodic Terahertz Antenna with CSRR Metamaterial Superstrate

Pankaj Kumar Singh
ME Student

Department of Electronics & Communication Engg.
NITTTR, Sector-26, Chandigarh, India

Garima Saini

Assistant Professor

Department of Electronics & Communication Engg.
NITTTR, Sector-26, Chandigarh, India

Abstract- In this paper a log-periodic terahertz antenna with CSRR metamaterial superstrate is proposed. A single-layer metamaterial structure, which utilized as a lens for the enhancement of gain of log-periodic terahertz antenna is used. The proposed metamaterial lens consists of a 6 x 6 matrix of Circular Split-Ring Resonators (CSRRs) and is placed above a probe-fed log-periodic terahertz antenna, resonating at 2.8 THz. The simulation result shows that the proposed antenna achieves +13.766 dB gain at 4.521 THz, which is about +4.136 dB higher than the maximum gain of the conventional antenna. The proposed antenna also offers a gain enhancement of 1.264 dB at 3.8462 THz.

Keywords- CSRRs, SRRs, SSRRs, THz, Metamaterials, Gain.

1. INTRODUCTION

Terahertz (THz) radiation offers many opportunities in various scientific and military applications because its interesting properties and its special interaction with many materials. The applications are radio astronomy, spectroscopy, terahertz imaging, space application or civil security. In general the intensity of THz signals is low and the effective detection area of the sensor is very small. In addition there is the difference between free space impedance and detector impedance result in high reflection losses. A bad coupling efficiency is consequence that that makes a detection of THz signals, even for high sensitive detectors like superconducting Hot-Electron Bolometers (HEBs), extremely difficult [1]. The solution of above problems is to use an antenna structure. The use of an antenna results in two main advantages. First, impedance matching of the detector to the free space wave can be achieved over high bandwidth. On the other hand, the effective detection area, that is proportional to the received radiation power, is increased significantly [1].

The appearance of metamaterials open the possibility for RF and microwave engineers to create structures with unconventional properties not found in nature.

The electromagnetic properties of metamaterials can be exploited to enhance the radiation characteristics of antenna [3]. These structures exhibit non-natural behavior, at predefined frequencies, such as very small or even negative permeability values [4].

In the literature, different metamaterials loaded patch antenna are reported to enhance the gain of antenna. The authors of [5] use metamaterials to design a high gain antenna for WiMAX application. There in, a four-layered metamaterial superstrate, consisting of 10x11 periodic

array of S-shape resonators, is placed above a rectangular patch. A 1.8 dB gain improvement is attained at resonance frequency as compared to original antenna. In [6] the metamaterial unit cell is engineered to have zero index of refraction within wide band. The metamaterial surface consists of 7x7 periodic unit cells.

By placing three layers of the proposed metamaterial surface above patch antenna, a 7.8 dB gain improvement is achieved. Author of [10] utilized a single layer metamaterial structure consist of 8 x 8 matrix of unit cell square SRRs. The antenna operates in terahertz range (1THz - 5.5THz). A maximum 1.11 dB gain improvement at 3.8462 THz achieved over conventional antenna.

In this context, a log-periodic terahertz antenna with CSRRs metamaterial superstrate is designed. The proposed metamaterial lens consists of a 6 x 6 matrix of circular split ring resonators (CSRRs) of PEC and is positioned above a probe-fed log-periodic terahertz antenna.

2. BASIC ANTENNA PRINCIPLES

In comparison to bow-tie or spiral antennas, log-periodic antennas are not real frequency independent antennas. These antennas are based on resonance effects which repeat periodically with the logarithm of the frequency. At a resonance frequency two teeth, which are in symmetry to the center of two adjacent resonance frequencies f_n and f_{n+1} depends on the scaling factor τ , the inner tooth radius r_n and outer tooth radius R_n in this way

$$\frac{f_n}{f_{n+1}} = \frac{R_{n+1}}{R_n} = \frac{r_{n+1}}{r_n} = \sqrt{\tau} \quad (2.1)$$

$$R_n = \tau^{n-0.5} * r_1 \quad (2.2)$$

$$r_n = \tau^{n-1} * r_1 \quad (2.3)$$

The bandwidth of the antenna is limited by the upper and the lower cut-off frequency. The upper cut-off frequency of the antenna is determined by the shortest tooth length. On the other hand, the longest tooth defines the lower cut-off frequency. If the variation of the impedance behavior between two resonances is sufficiently small, the antenna can be assumed as approximately frequency independent [2]. Up to now, two different theories of the principle of operation are present in literature. According to the first theory [7], the log-periodic antenna is considered as a half-wavelength resonator. The resonator consists of two parts:

the length of tooth arc with angle α and the length of a bow-tie segment with angle β . In the second model [8] the teeth are expected to operate as quarter-wavelength resonator with no influence of the bow-tie structure. In the following the log-periodic terahertz antenna type is examined for the half wavelength resonance effect. The lengths of described paths are

$$l_n = r_n (1 + \sqrt{\tau}) * \frac{\alpha\pi}{180^\circ} + r_n (\sqrt{\tau} - 1) \quad (2.4)$$

And hence the corresponding resonance frequencies are

$$f_n = \frac{c_0}{2 \left(r_n (1 + \sqrt{\tau}) * \frac{\alpha\pi}{180^\circ} + r_n (\sqrt{\tau} - 1) \right) \sqrt{\epsilon_{eff}}} \quad (2.5)$$

3. METAMATERIAL UNIT CELL CHARACTERIZATION

The metamaterial unit cell shown in fig.3.1 is used as the building block of the beam-focusing substrate. This kind of unit cell is called Split-Ring Resonator (SRR). Split Ring Resonator is formed by a pair of concentric loops with splits at opposite ends.

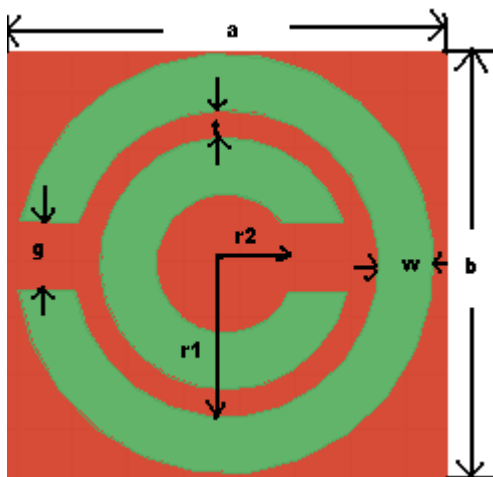

Fig.3.1 A top view of the CSRR metamaterial unit cell

The unit cell strip lines are printed on a Rogers RT/duroid 5880 substrate with relative permittivity $\epsilon_r = 2.2$. The circular SRR related parameters are shown in table 3.1. Ansoft HFSS, a FEM-based solver is used to calculate the scattering parameters of unit cell [9].

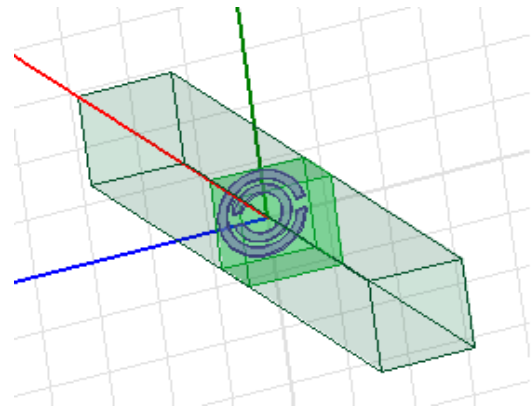

Fig. 3.2 The simulation setup in HFSS for unit cell

The geometrical dimensions of the circular SRR are summarized in table 3.1. The simulated scattering parameters of the unit cell circular SRR are shown in fig. 3.3.

TABLE 3.1 THE GEOMETRICAL PARAMETERS OF THE CIRCULAR SRR

a (μm)	b (μm)	r_1 (μm)	r_2 (μm)	g (μm)	w (μm)	t (μm)
16	16	5.5	2.5	2	2	1

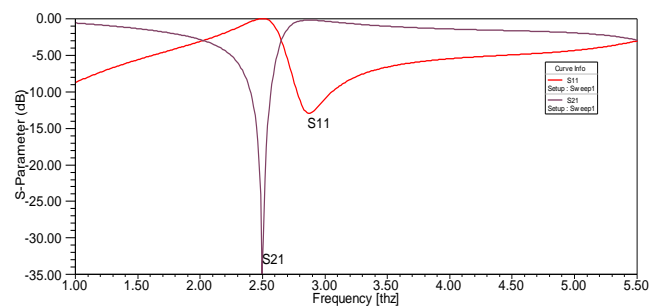

Fig.3.3 The simulated S_{11} and S_{21} of the CSRR with respect to frequency

It can be noticed that circular SRR has a resonance at 2.8 THz. The normalized permittivity of the CSRR, extracted from S-parameters shown in fig.3.4. It can be notice that around 2.8 THz to 5.5 THz, the permittivity of the structure is negative. Thus, this circular SRR constitutes a negative index material medium at the 2.8 THz range.

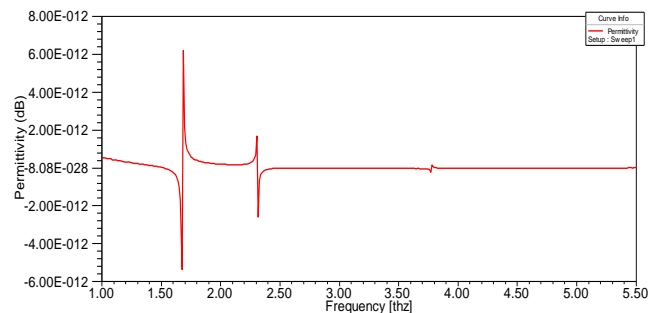

Fig.3.4 The Permittivity of the CSRR.

4. ANTENNA DESIGN USING A METAMATERIAL SUPERSTRATE

The SRR, presented in the previous section, is employed as a key building block of a superstrate position above a log-periodic terahertz antenna. The superstrate consist of 6 x 6 periodic arrays of circular SRRs. These unit cells are separated by 1 μm from each other in both the x and y directions. A 10 μm x 10 μm blank space at the four superstrate corners is left to provide solid support of the log-periodic terahertz antenna and the superstrate. The space between the radiating patch and the bottom surface of the metamaterial is $h = 66.5 \mu\text{m}$. The radiating log-periodic terahertz antenna is printed on a 100 μm x 100 μm x 50 μm silicon substrate. The center of the log-periodic terahertz antenna is aligned with that of the superstrate. The top-view of conventional log-periodic terahertz antenna is shown in fig.4.1.

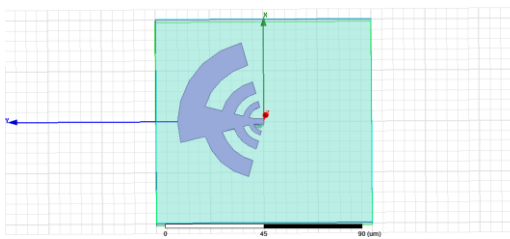

Fig.4.1 The top view of log-periodic terahertz antenna without metamaterial.

TABLE 4.1
 GEOMETRICAL PARAMETERS OF THE SIMULATED ANTENNA

r_1 [μm]	α [deg]	β [deg]	n	τ
5	60	30	6	$\sqrt{2}$

The 3D view of log-periodic terahertz antenna with circular SRR metamaterials is shown in fig.4.2.

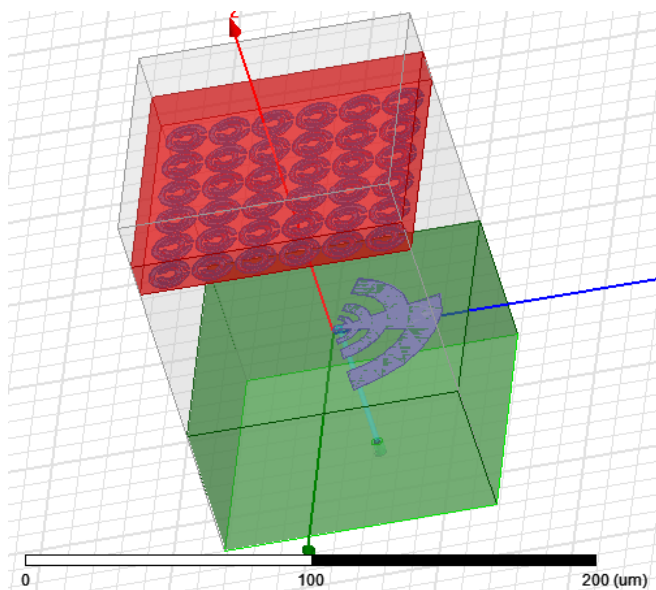

Fig.4.2 The 3-D view of proposed antenna

The height h of the superstrate is the distance between the log-periodic patch and the metamaterial board, the optimization of height is done using [3]. The probe-fed log-periodic terahertz antenna is designed to operate at frequencies of 2.395 THz, 2.912 THz, 3.385 THz, 3.846 THz and 4.521 THz.

The computed S_{11} plots of the conventional antenna and proposed antenna is shown in fig.4.3. The presence of the metamaterial does not affect the resonance conditions of original antenna, which is approximately same as a conventional antenna frequencies.

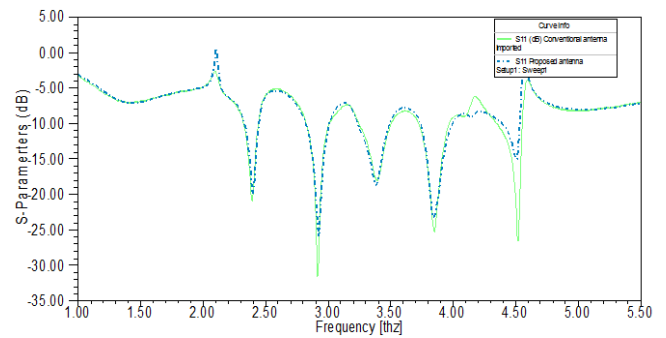

Fig.4.3 The simulated S_{11} parameters of conventional antenna (continuous line) and proposed antenna (dashed line)

The maximum gain of log-periodic terahertz antenna without metamaterial at 4.521 THz is +9.63 dB, clear from the 3D radiation pattern of the log-periodic terahertz antenna without metamaterial, as shown in fig.4.4.



Fig.4.4 3-D radiation pattern of log-periodic terahertz antenna without metamaterial

The maximum gain of proposed antenna at 4.521 THz is +13.766 dB, which is approximately 4.136 dB higher than original. The fig.4.5 show the 3D radiation pattern of proposed antenna.

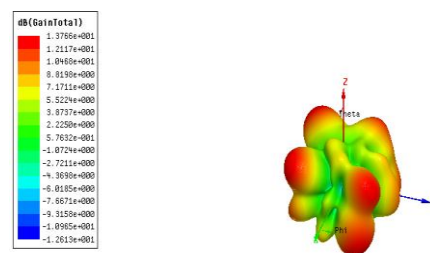

Fig.4.5 3-D radiation pattern of proposed antenna

Table 4.1 shows the resonance frequency vs gain of log-periodic terahertz antenna and proposed antenna.

S no.	Resonance Freq. (THz)	S_{11} (dB)	Gain Conventional (dB)	Gain Proposed antenna (dB)	Diff. Gain (dB)
1	2.395	-21.0	-2.897	-2.299	+0.598
2	2.912	-31.5	+1.09	+0.400	-0.690
3	3.385	-17.9	-0.815	-1.486	-0.671
4	3.846	-25.3	+0.55	+1.814	+1.264
5	4.521	-26.6	+9.63	+13.766	+4.136

Table 4.1 shows that the gain of proposed antenna are enhance by +0.598 dB, -0.69 dB, -0.671 dB, +1.264 dB and +4.136 dB at frequencies 2.395 THz, 2.912 THz, 3.385 THz, 3.846 THz and 4.521 THz respectively.

Table 4.2 shows the gain comparison of conventional antenna, antenna with square SRRs [10] and proposed antenna

S. no.	Resonance Freq. (THz)	Gain (dB) (Conventional)	Gain (dB) (With SSRR)	Gain (dB) (With CSRR)
1	2.395	-2.897	-2.395	-2.299
2	2.912	+1.09	+0.901	+0.400
3	3.385	-0.815	-0.668	-1.486
4	3.846	+0.55	+1.655	+1.814
5	4.521	+9.63	+9.991	+13.766

5. CONCLUSIONS

A log-periodic terahertz antenna with circular SRRs (CSRRs) metamaterial superstrate is proposed and a single layer metamaterial surface is used as a lens to enhance the gain of log-periodic terahertz antenna. This metamaterial structure is a 2-D array of Circular Split-Ring Resonators (CSRRs) where effective permittivity is negative at resonance frequency. The lens is positioned above a log-periodic terahertz antenna resonating at 2.8 THz to validate the beam focusing ability. The simulation result shows that the proposed antenna offers a gain improvement of about +4.136 dB at 4.521 THz, in working range of metamaterial superstrate, offers a maximum gain of 13.766 dB. At 3.846 THz the proposed antenna also offers a gain improvement of 1.814 dB, which is better than gain offer by log-periodic terahertz antenna with square SRRs (SSRRs).

REFERENCES

- [1] A. Scheuring, A. Stockhausen, S. Wuensch, K. Ilin, M. Siegel, "A new analytical Model for log-periodic Terahertz Antennas," Antennas and Propagation (EuCAP), 2010 Proceeding of The Fourth European Conference on Publication pp-1-5 Year 2010.
- [2] A. Scheuring, S. Wuensch, and M. Siegel, "A novel analytical model of resonance effects of log-periodic planar antennas," Antennas and Propagation, IEEE Transactions on, vol. 57, no. 11, pp. 3482-3488, Nov. 2009.
- [3] Ferhad Kasem, Mohammed Al-Husseini, Karim Y. Kabalan, Ali El-Hajj and Youssef Nasser, "A High Gain Antenna with a Single-Layer Metamaterial Superstrate", Mediterranean microwaves symposium (MMS), 2013 13th pp-1-4, Publication Year 2013.
- [4] R. Marques, F. Martin, and M. Solla, Metamaterials with Negative Parameters: Theory, Design and Microwave Application. Wiley, 2008.
- [5] H.-H. Lin, C.-Y. Wu, and S.-H. Yeh, "Metamaterial enhanced high gain antenna for WiMAX application," TENCON IEEE Region Conference, pp. 1-3, October 2007.
- [6] D. Li, Z. Szabo, X. Qing, E.-P. Li, and Z.-N. Chen, "A high gain antenna with an optimized metamaterial inspired supersaturate," IEEE Trans. on Antennas and Propagation, vol. 60, no. 12, pp. 6018 - 6023, December 2012.
- [7] M. Gitin, F. Wise, G. Arjavalingham, Y. Pastol, and R. Compton, "Broadband characterization of millimeter-wave log-periodic antenna by photoconductive sampling," Antenna and Propagation, IEEE transactions on, vol. 42, no. 3, pp. 335-339, Mar 1994.
- [8] R. DuHamel and D. Isbell, "Broadband logarithmically periodic antenna structure," IRE international Convention Record, vol. 5, pp. 119-128, Mar 1957.
- [9] Ansoft HFSS, Version 13.0 <http://www.ansoft.com/products/hf/hfss>.
- [10] P. K. Singh, G. Saini, "Log-periodic Terahertz antenna with square SRR metamaterial superstrate," International journal of engineering research & technology, vol. 5, Issue 07, pp.527-530, July-2016.

Authors



First Author- Pankaj Kumar Singh is a ME Student of Electronics & Communication Engineering in NITTTR, Chandigarh, have done B-Tech (ECE) from UPTU Lucknow and Diploma (Electrical Engg.) from Govt. Poly. Ghazipur (UPBTE). The area of interest is micro-electronics, Wireless Communication, antenna & microwave.



Second Author-Mrs. Garima Saini Assistant Prof. in ECE Department at NITTTR Chandigarh. She has done M-Tech (ECE) From PTU Jalandhar and B-Tech (ECE) from Kurukshetra University, Kurukshetra. Her area of interest is Mobile Communication, Wireless Communication & Network, Advance Digital Communication and antenna.