

Minimax Approach: An Efficient Technique for Image Denoising

Mr. Satish S,
Assistant Professor,
Electronics & Communication,
Brindavan College Of Engineering

Mrs. Bhagyashree K,
Assistant Professor,
Computer Science & Engineering,
Brindavan College Of Engineering

Mrs. Manjula K B
Assistant Professor
Electronics & Communication
Engineering
Brindavan College Of Engineering

Abstract: This paper proposes a robust wavelet shrinkage approach for image denoising. Removal of noise is critical in the image reconstruction process, but denoising of image is still a challenging task. Denoising is used to remove the noise from corrupted image, while preserving the edges and other detailed features to a larger extent. This noise is added during acquisition, transmission & reception and even in storage & retrieval processes. Wavelet shrinkage is an image denoising technique based on the concept of thresholding the wavelet coefficients. Thresholds can be of either hard or soft estimates. Hard thresholding is a keep or kill rule whereas soft thresholding shrinks the coefficients above the threshold in absolute value. We are emphasizing on soft thresholds. The key challenge of wavelet shrinkage is to find an appropriate threshold value, which is typically controlled by the signal variance.

Keywords: Image denoising, Wavelet transforms.

I. INTRODUCTION

The image is corrupted with noise during acquisition process and noise has to be eliminated in image processing during reconstruction. According to actual image characteristic, noise statistical property and frequency spectrum distribution rule, there have been many methods of eliminating noises, which approximately are divided into space and transformation fields. The space field is data operation carried on the original image, and processes the image grey value, like neighborhood average method, wiener filter, center value filter and so on. The transformation field is management in the transformation field of images, and their coefficients after transformation are processed. The main aim of eliminating noise is achieved by inverse transformation, like wavelet transform [1,2]. Successful exploitation of wavelet transform might lessen the noise effect or even overcome it completely. There are two types of wavelet transform, continuous and discrete. The discrete transform is very efficient from the computational point of view [3,4]. In this paper, we will deal with the modeling of the wavelet transform coefficients of test images and its application to the image denoising problem. The denoising of a natural image corrupted by Gaussian noise is a challenging task in image processing.

The proposed shrinkage is efficient in dealing with image denoising corrupted by Gaussian noise.

The paper is organized as follows. Section 2 introduces the concept of wavelet transforms. Section 3 explains the thresholding techniques and proposed method for image denoising. Section 4 describes the experimental results at various noise levels of test images. Finally the concluding remarks are given in section 5

II. WAVELET TRANSFORMS

The wavelet transform is very efficient to address this problem due to its energy compaction property [5]. Indeed, wavelets provide a framework for signal decomposition in the form of a sequence of signals known as approximation signals with decreasing resolution supplemented by a sequence of additional touches called details [6,7]. Denoising or estimation of functions, involves reconstruction of the signal from the noisy image [8,9,10,11]. The methods based on wavelet representations yield efficient algorithm [12]. It consists of decomposing the given signal into wavelets and using thresholds to select the coefficients, from which a signal is synthesized [5]. Image denoising algorithm consists of few steps, consider an input signal $x(t)$ and noisy signal $n(t)$. Add these components to get noisy data $y(t)$ which is given by equation 1

$$y(t) = x(t) + n(t) \quad (1)$$

Here the noise can be Gaussian, Poisson's, speckle and Salt and pepper, then apply wavelet transform to get $w(t)$, which is given by equation 2

$$y(t) \xrightarrow{\text{wavelet transforms}} w(t) \quad (2)$$

Modify the wavelet coefficient $w(t)$ using different threshold algorithm and take inverse wavelet transform to get denoising image $\hat{x}(t)$, which is given by equation 3

$$w(t) \xrightarrow{\text{inverse wavelet transforms}} \hat{x}(t) \quad (3)$$

The discrete wavelet transforms can be mathematically defined as equation 4 and 5

$$\mathcal{W}_\phi[j_0, k] = \frac{1}{\sqrt{M}} \sum_n f[n] \Phi_{j_0, k}[n] \quad (4)$$

$$W_{\psi}[j, k] = \frac{1}{\sqrt{M}} \sum_n f[n] \psi_{j,k}[n] \quad j \geq 0 \quad (5)$$

Equation 4 gives approximation coefficients and equation 5 gives detailed coefficients.

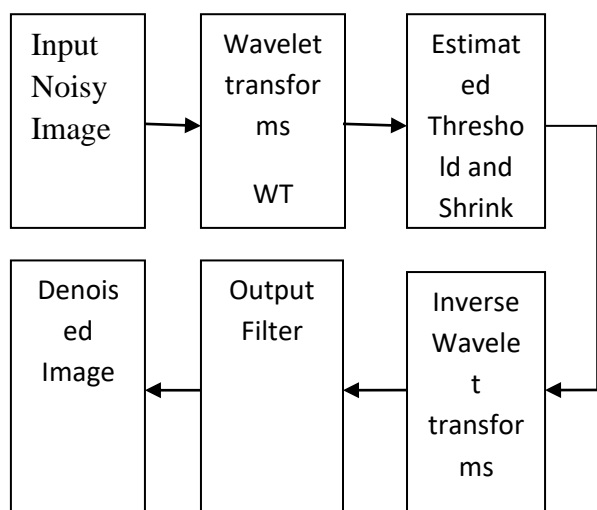

Fig 1: Block diagram of Image denoising using wavelet transform.

Image quality was expressed using signal to noise ratio of denoised image.

Discrete wavelet transform (DWT) decomposes an image into different sub images [5]. Denoising algorithm using DWT decomposes the noised images obtaining the wavelet coefficients [6,7,8]. These coefficients are then denoised with wavelet threshold. Finally, inverse transform is applied to the coefficients and get denoised image [9]. This process is the reconstruction of an image using decomposition or analysis of applied noised image.

DWT decomposes an image into different sub band images, namely low-low (LL), low-high (LH), high-low (HL) and high-high (HH). The sub-band (LL) is the low resolution residual [10,11]. The wavelet-thresholding denoising method filters each coefficient from the detail sub bands with a threshold function to obtain modified coefficients. The de-noised estimated by inverse wavelet transform of the modified coefficients. Here, the threshold plays an important role in the de-noising process [12]. There are two thresholding methods frequently used. The soft threshold function and the hard thresholding function.

The wavelet thresholding procedure removes noise by thresholding only the wavelet coefficients of the detail sub-bands, while keeping the low resolution coefficients unaltered. Hard thresholding is a keep or kill rule whereas soft thresholding shrinks the coefficients above the threshold in absolute value. De-noising of natural images corrupted by Gaussian noise using wavelet techniques is very effective because of its ability to capture the energy of a signal in few energy transform values. Finding an optimum threshold is a tedious process. A small threshold value will retain the noisy coefficients whereas a large

threshold value leads to the loss of coefficients that carry image signal details.

LL2	HL2	HL1
LH2	HH2	
LH1		HH1

Fig 2. Decomposition of image for 2 levels.

In our experiment, we have decomposed the image for 5 levels.

III. THRESHOLDING TECHNIQUES FOR IMAGE DENOISING

Selection of threshold in image denoising is an important factor. The techniques used for shrinkage is Visu shrink, Sure shrink and Minmax shrink. The parameter used to compare these techniques is power to signal noise ratio (PSNR).

$$PSNR = 10 \log_{10} \left(\frac{255^2}{MSE} \right) \quad (6)$$

A. Visu Shrink:

Visu shrink was introduced by Donoho. It uses threshold value 't' that is proportional to the standard deviation [13]. It follows hard thresholding rule. It is also referred to as universal threshold. This threshold is given by

$$t = \sigma \sqrt{2 \log M} \quad (7)$$

where σ is the noise variance and M is the of number pixels in the image. An estimate of the noise level σ defined based on the median of absolute deviation and it is given by,

$$\hat{\sigma} = \frac{\text{median}(\{|g_{j-1,k}| : k=0,1,2,\dots,2^{j-1}-1\})}{0.6745} \quad (8)$$

Where $g_{j-1,k}$ corresponds to the detailed coefficient in the wavelet transform. The main drawback of VisuShrink is that it does not deal with minimizing the mean squared error. Another disadvantage is that it cannot remove speckle noise [13]. It can only deal with an additive noise. For the denoising purpose this method is found to give up a smooth estimate. It follows the global thresholding scheme; here global threshold means a single value of threshold applied globally to all the wavelet coefficients.

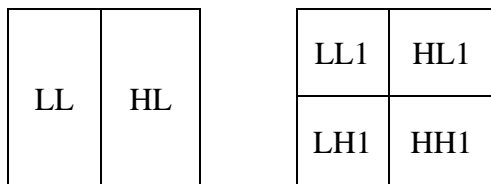

B. Sure shrink:

A threshold chooser based on the steins unbiased risk estimator (SURE) proposed by Donoho and Johnstone called sure shrink. It is a combination of both universal threshold and SURE threshold. This method specifies a threshold value t_j for each resolution level j in the wavelet transform which is referred to as level dependent thresholding [13]. The main advantage of sure shrink is to minimize the mean squared error and defined as:

$$MSE = \frac{1}{n^2} \sum_{x,y=1}^n (z(x,y) - s(x,y))^2 \quad (9)$$

Where $z(x,y)$ is the estimate of the signal and $s(x,y)$ signal. Sure shrink is a thresholding by applying a sub band adaptive threshold. It is based on the stein's unbiased risk estimator, a method for estimating the loss in an unbiased fashion. Sure shrink suppresses noise by thresholding the empirical wavelet coefficients and it follows soft thresholding rule. Sure shrink threshold t_s is given by,

$$t_s = \min(t, \sigma \sqrt{2 \log n}) \quad (10)$$

where denotes t the value that minimizes Stein's Unbiased Risk Estimator, σ is the noise variance computed and an estimate of the noise level σ defined based the median of absolute deviation is given by

$$\hat{\sigma} = \frac{\text{median}(\{|g_{j-1,k}| : k=0,1,2,\dots,2^{j-1}-1\})}{0.6745} \quad (11)$$

And n is the size of the image.

It follows the soft thresholding rule. The thresholding employed here is adaptive, i.e., a threshold level is assigned to each resolution level by the principle of minimizing the Stein's Unbiased Risk Estimator for threshold estimates. It is smoothness adaptive, which means that if the unknown function contains abrupt changes or boundaries in the image, the reconstructed image will also have the same.

C. MINMAX Shrink

The threshold value is calculated using minmax principle. The minimax estimator is the one that realizes the minimum of the maximum MSE obtained for the cost function [14]. The minimax threshold is computed by

$$\lambda = 0.394 + 0.264 \log M \quad (12)$$

Where M is the number of pixels in the image. It has the advantage of giving good predictive performance.

IV. EXPERIMENTAL RESULTS

The experiments were conducted on gray scale test image Barbara and Lena of size 512x512 at different noise levels ($\sigma=10, 15, 20$) combined with various thresholding such as Visu shrink, Sure shrink and Minmax shrink. The wavelet transform that we have used is Daubechies's least asymmetric compactly supported wavelet with ten (db10) vanishing moments at five levels of decomposition. In this experiment, we choose PSNR as performance criteria. The greater PSNR shows that our method minmax shrink gives better noise suppression without artifacts. PSNR values of test image Barbara and Lena with DWT shown in Table 1&2.

$$PSNR = 10 \log_{10} \left(\frac{255^2}{MSE} \right) \quad (13)$$

Where MSE is the mean square error between the original (i.e. x) and the de-noised image (i.e. \hat{x}) with size $M \times N$

$$MSE = \frac{1}{M \times N} \sum_{i=1}^m \sum_{j=1}^n [x(i,j) - \hat{x}(i,j)]^2 \quad (14)$$

TABLE 1: PSNR (dB) OF BARBARA IMAGE FOR DIFFERENT SHRINKS

Noise Variance(σ)	Visu shrink	Sure shrink	Minmax shrink
10	27.0258	28.1376	29.7835
15	25.1825	24.5870	26.7489
20	24.0225	22.1066	24.5979

TABLE 2: PSNR (dB) OF LENA IMAGE FOR DIFFERENT SHRINKS

Noise Variance(σ)	Visu shrink	Sure shrink	Minmax shrink
10	30.0334	28.1362	30.5707
15	28.3435	24.6527	27.6371
20	27.2127	22.1244	25.4467

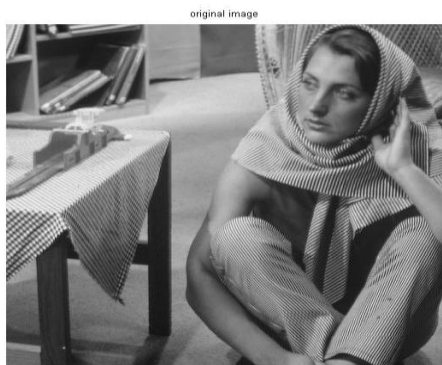

(a)

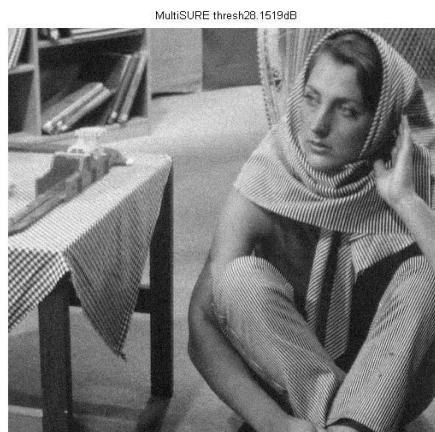

(d)

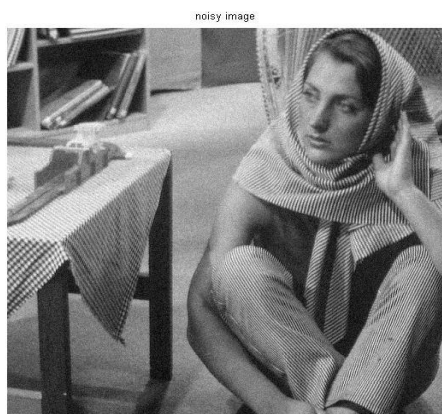

(b)



(e)



(c)

Fig 3: Barbara images (a) Original (b) Noisy (c) Visu shrink (d) Sure shrink (e) Minmax shrink



(a)

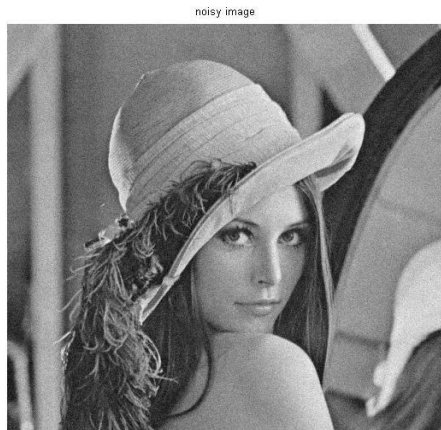

(b)



(e)



(c)

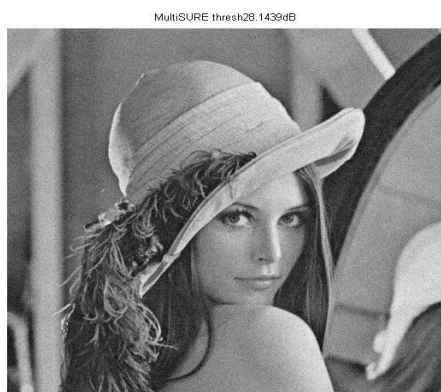

(d)

Fig 4: Lena images (a) Original (b) Noisy (c) Visu shrink (d) Sure shrink (e) Minmax shrink

V. CONCLUSION

In this paper, the image denoising using wavelet transform is implemented for various shrinkage rules with thresholding function applied to the test images with different noise levels. Peak signal to noise ratio is taken as performance measure, different PSNR value for different shrinkage methods are shown in tables above. The results shows that Minmax shrink gives better result than visu and sure shrink in terms of peak signal to noise ratio and visual quality of the denoised image improves significantly over the noisy image.

ACKNOWLEDGEMENT

We would like to extend our heartfelt gratitude to all those who have contributed to the successful completion of this research and publication. Without their support, expertise, and encouragement, this work would not have been possible.

We are also grateful to Brindavan College of Engineering for their support, which played a significant role in facilitating our research efforts.

REFERENCES

- [1] Donoho.D.L,Johnstone.I.M, "Ideal spatial adaptation via wavelet shrinkage", Biometrika,81,pp.425-455,1994.
- [2] Gao Zhing, Yu Xiaohai, "Theory and application of MATLAB Wavelet analysis tools", National defense industry publisher,Beijing,pp.108-116, 2004.
- [3] Aglika Gyaourova Undecimated wavelet transforms for image denoising ,November 19, 2002.
- [4] Bart Goossens, Aleksandra Pi`zurica, and Wilfried Philips, "Image Denoising Using Mixtures of Projected Gaussian Scale Mixtures", IEEE Transactions On Image Processing, Vol. 18, No. 8, August 2009, Pp.1689-1702
- [5] Michel Misiti, Yves Misiti, Georges Oppenheim, Jean-Michel Poggi, "Wavelets and theiApplications", Published by ISTE 2007 UK.
- [6] C Sidney Burrus, Ramesh A Gopinath, and Haitao Guo, "Introduction to wavelet and wavelet transforms", Prentice Hall1997.S. Mallat, A

Wavelet Tour of Signal Processing, Academic, New York, second edition, 1999.

- [7] R. C. Gonzalez and R. Elwood's, Digital Image Processing. Reading, MA: Addison-Wesley, 1993.
- [8] M. Sonka, V. Hlavac, R. Boyle Image Processing , Analysis , And Machine Vision. Pp10-210 & 646-670
- [9] Raghuvver M. Rao., A.S. Bopardikar Wavelet Transforms: Introduction To Theory And Application Published By Addison-Wesley 2001 pp1-126
- [10] Arthur Jr Weeks , Fundamental of Electronic Image Processing PHI 2005.
- [11] Jaideva Goswami Andrew K. Chan, "Fundamentals Of Wavelets Theory, Algorithms, And Applications", John Wiley Sons
- [12] Chang, S. G., Yu, B., and Vetterli, M. (2000). Adaptive wavelet thresholding for image denoising and compression. IEEE Trans. On Image Proc., 9, 1532–1546.
- [13] Sachin D Ruikar and Dharpal D Doye "Wavelet Based Image Denoising Technique" IJACSA, Mar 2011.
- [14] S.Sulochana and R.Vidhya "Image Denoising using Adaptive Thresholding in Framelet Transform Domain" IJACSA, Vol 9, 2012.