

Minimizing Penalty by Engaging APFC Unit for Industries

Nandish B M

Dept. Electrical and Electronics
Jain Institute of Technology
Davangere, India

A Ambika

Dept. Electrical and Electronics Engineering
Jain Institute of Technology
Davangere, India

Aliya Tabassum R

Dept. Electrical and Electronics Engineering
Jain Institute of Technology
Davangere, India

Arsheeya Kousar M

Dept. Electrical and Electronics Engineering
Jain Institute of Technology
Davangere, India

Keerthi P E

Dept. Electrical and Electronics Engineering
Jain Institute of Technology Davangere,
India

Abstract— Induction motors and other industrial loads typically run at moderately low power factors. Since motors make up about 60% of the utility load, the power system's total power factor is poor. These motors are intrinsically low power factor devices, depending on the load level. Depending on the size of the motor and other operational factors, the power factor of these motors ranges from 0.30 to 0.95. Therefore, industrial power systems, utilities, and users are always concerned with the power factor level. The system performance can be raised through power factor correction. A growing number of capacitor banks are being designed as a result of the rise in power electronic-based products. To enhance, shunt capacitor banks are used.

Keywords—Shunt Capacitor Bank, Industrial Loads, Power Factor, and Power Factor Correction.

I. INTRODUCTION

The majority of plant loads are inductive, therefore to run motors, transformers, and fluorescent lighting, a magnetic field is necessary. Although essential, the magnetic field does not generate any useful work. To create the productive work, the utility must provide the energy. Active and reactive current are the two different types. Shunt capacitor banks are primarily deployed to offer capacitive reactive compensation/power factor adjustment. Because SCBs are inexpensive, simple, and quick to install, their use has expanded. Other positive impacts of its installation on the system include an increase in voltage at the load, better voltage regulation, a decrease in losses, and a reduction or deferral of investment in gearbox. Power factor capacitors are static devices without moving parts and need minimal maintenance. As a result, shunt capacitors.

POWER FATOR

Real and reactive components combine to form the current needed by computers, lights, and motors. It is useful to comprehend the capacitor current in terms of a two component current. Only the genuine component of current needs to be supplied to loads like heaters. Reactive and actual currents are required by some loads, such as an induction motor. The component that is turned by the machinery into meaningful work, such as the production of heat through a heater element, is known as the actual current. Amperes (A) are used to measure current, and watts (W) are used to measure power (voltage, real current). The element required to generate the flux required for the operation of induction devices is the reactive current. The

current is calculated using ampere (A) and the reactive power in VARs.

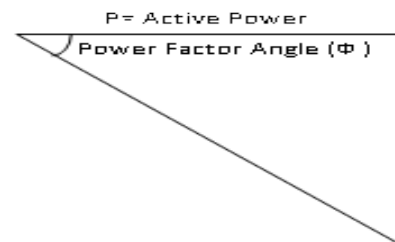

The working power to apparent power ratio, or kW/kVAR, is known as the power factor. Values for the power factor range from 0 to 1.00. Values typically fall between 0.80 to 0.98. low power factors are those below 0.80.

Fig.1 Power Triangle

LAGGING POWER FACTOR

In ac circuits lagging power factor, is achieved when the load is inductive in nature. This is so because when a purely inductive or resistive inductive load is present then there exists a phase difference between voltage and current in which the current lags the voltage. Thus the power factor of such circuits is of lagging nature.

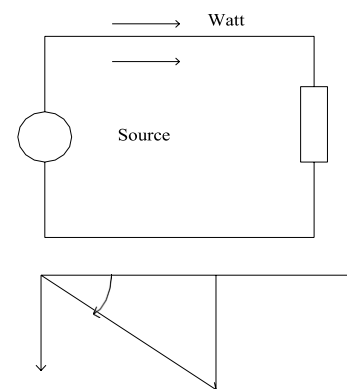
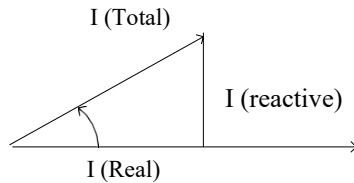

Fig.2 The Concept of Lagging Power Factor
LEADING POWER FACTOR

In ac circuits lagging power factor, is achieved when the load is inductive in nature. This is so because when a purely inductive or resistive inductive load is present then there exists a phase difference between voltage and current in which the current lags the voltage. Thus the power factor of such circuits is of lagging nature.



**Fig.3 The concept of leading power factor
POWER FACTOR IMPROVEMENT**

The majority of industrial loads, including induction motors, function at comparatively low power factors. The power system's total power factor is low since motors make up about 60% of the utility load. These motors are innately low power factor devices, depending on the intensity of the load. These motors have a power factor that ranges from 0.30 to 0.95 depending on the size of the motor and other operational factors. As a result, utilities, users, and industrial power systems are always concerned with the power factor level. By adjusting the power factor, the system performance can be enhanced. System power factor is determined by: $P/kVA = \text{Power Factor}$ (1) Where real power is denoted by P, and apparent power by kVA. Table 1 depicts the relationship between the power factor and the Q/P ratio. Table 1 shows that the reactive power consumption is 48% of the real power even at 90% power factor. The need for reactive power is substantially higher with low power factors. Therefore, all industrial facilities must use some sort of power factor correction.

Any operating system may have a lagging or leading power factor. The kind of the power factor can be determined using the direction of the active and reactive power. The power factor is trailing if the real and reactive power flows are going in the same direction. The power factor is leading if the reactive power moves in the opposite direction of the real power. An induction motor is a typical load with a trailing power factor. A capacitor is an example of a leading power factor load. In an industrial plant, power factor enhancement is typically possible for three reasons.

A. Reduce a plant's use of electricity By implementing any of the aforementioned solutions, a power factor improvement in the plant will typically make up for the losses and lower current loads on the supply equipment, such as cables, switchgear, transformers, and generating plants. Therefore, anytime there is room for correction, power factor adjustments will lower the plant's overall electricity usage and, consequently, its electricity costs. The savings are not quantifiable since many of these losses are not carefully documented in many sectors. This could be one of the arguments used to support the claim that PF enhancement only lowers the cost of electricity in cases when the power utility is using a tariff where a reactive power demand charge is included in the monthly electricity bill. Power factor improvement will result in a decrease in electricity consumption when it is implemented at the equipment level or at the control centre level (a case study is provided to illustrate the savings in both of these cases). However, if the plant, which is receiving power from a common grid, makes the correction

at the supply voltage/incoming voltage level only to make up for the reactive power drawn from the grid, the decrease in electricity consumption will not occur.

B. Only lower electricity costs

Only when the plant receiving power from a common grid does the correction at the supply voltage/incoming voltage level,

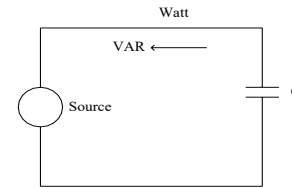

merely to make up for the reactive power drawn from the grid, can power factor correction lower the cost of electricity. The contract demand in a plant is frequently set on a fake consumption in the plant, thus even this improvement in PF may not necessarily result in a decrease in the cost of power. Contract demand is frequently established based on future expansion plans and a high variety factor considered during design stages. A reduction in kVA may not yield any benefits as long as the contract demand is re-fixed to actual value since, in the majority of circumstances, utilities charge for a minimum contract demand regardless of use. The PF is often increased to 0.95-0.98, although increasing the PF further to unity may result in longer payback times.

C. Lower the price of power and the amount of electricity used. In all other circumstances, excluding the one indicated above, improving power factor will eventually result in lower electricity usage and, consequently, lower electricity costs. However, the type of installation and a number of other factors, such as power tariffs, equipment loading patterns, methods of generating and using power, plant operating philosophies, etc., affect the payback on investment due to power factor correction.

D. Power Factor Correction's Benefits One benefit of using the proper power factor correction is that system losses including losses in cables, lines, and feeder circuits can be reduced, allowing for smaller sizes to be chosen

1. Improved system voltages make it possible to keep motors, pumps, and other equipment at their rated voltage. The resistive loss caused by the voltage drop in supply cables consumes energy by heating the conductors. A 5% voltage drop results in a 5% loss of power as heat before it even reaches the motor. Reduce line current and line losses to increase power factor, especially at the motor terminals, to increase efficiency.

2. Better control of voltage.

3. Enhanced system capacity by the release of kVA capacity of transformers and cables for the same kW, allowing for higher loads without needing to immediately increase capacity.

SHUNT CAPACITOR BANK ESSENTIALS

Modern power networks need more distributed voltage support than ever before to operate economically. The characteristics of distributed generation and load have also altered, necessitating more VAR assistance across the entire power system. The most cost-effective way to integrate VARs into the system is through capacitor banks. The shunt capacitor banks can be deployed at feeders, high voltage systems, extra high voltage systems, loads, and distribution systems. feeders, extra-high voltage systems, high voltage systems, or loads. The capacitor banks can also be used at grid loads, branch locations, or individual

loads. The banks can also be exchanged or fixed. These capacitor banks can be switched using a variety of techniques. In distribution and high voltage systems, where a sizable amount of reactive power is provided to the power system, shunt capacitor installations are used. Additionally, when a capacitor unit fails, the voltage of the remaining working capacitor units rises. These voltages must stay within allowable bounds. The capacitor units are produced, examined, and used in applications requiring power factor correction. For safe and effective functioning, the applicable parameters must be properly specified. Voltage, frequency, insulation class, momentary ratings, nominal kVAR rating, and permitted operational service conditions are some of the specifications that apply to these devices. Shunt capacitors are utilised at the motor terminals to account for reactive power.

II PROBLEM STATEMENT

A load that uses alternating current needs apparent power, which is made up of both actual and reactive power. The power that the load actually uses is known as real power. Reactive power is the cyclical effect that happens when alternating current passes through a load containing a reactive component. Reactive power is repeatedly demanded by the load and given back to the power source. When reactive power is present, the true power is always less than the perceived power, causing electrical loads to have a power factor below 1. The current flowing between the power source and the load is increased by reactive power, which also results in an increase in power losses along transmission and distribution lines. Power firms suffer operational and financial losses as a result.

In order to avoid additional fees, power providers mandate that their clients, particularly those with heavy loads, keep their power factors above a predetermined level.

III OBJECTIVES

The project's main goal was to develop corrective machinery that could measure the electrical system's power factor and raise it to a target level. The following goals guided the research investigations that were conducted:

- The major goal of the proposed system is to use MATLAB simulation to keep the induction motor's power factor close to unity with or without a capacitor bank.
- To ascertain the load's current power factor status.
- Increasing PF level to reduce power loss.
- Constantly keeping an eye on load power use.

IV METHODOLOGY

The below figure shows the block diagram. It contains three phase power supply, three phase transformer, three phase V-I characteristics, three phase parallel RLC load, three phase

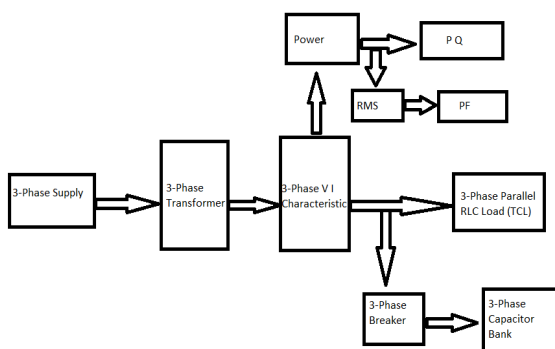

breaker, three phase capacitor bank, power block, RMS, PQ and PF block.

Fig. 4 Block Diagram

It contains generation system and output of the generator is 6628 connected to 11kv/400v, transformer is transmitted through the transmission line and the output supply is connected to R-L load. Which drawing the power factor the 0.6628 to improve the power factor of the system the calculation the capacitor bank should be required. After calculating the capacitor value it will be inserted in between line and load through the breaker. The power factor of the system will improved to 0.9038.

V ADVANTAGES and DISADVANTAGES

ADVANTAGES

- Support for reactive power
- Increased energy loss savings
- Decreasing line and transformer loss
- Increased power system capacity
- Voltage profile improvements

DISADVANTAGES

- Capacitor have a brief service life of 8 to 10 years.
- If the voltage is more than what is recommended, they are quickly damaged.
- When capacitors are destroyed, it is not cost-effective to repair them.

VI APPLICATIONS

- It is applicable to industrial use.
- Substations and appliances regulate the functioning of major dams used for power generating.
- To boost inductive loads like induction motors' power factors.
- It can be utilised in substations and offers effective voltage regulation.

VII RESULT

In this project, the three phase system and the power factor of the system will be correct by using capacitor bank, which is connected in parallel near to the load. The load used in this system will be a balanced load. The value of power factor

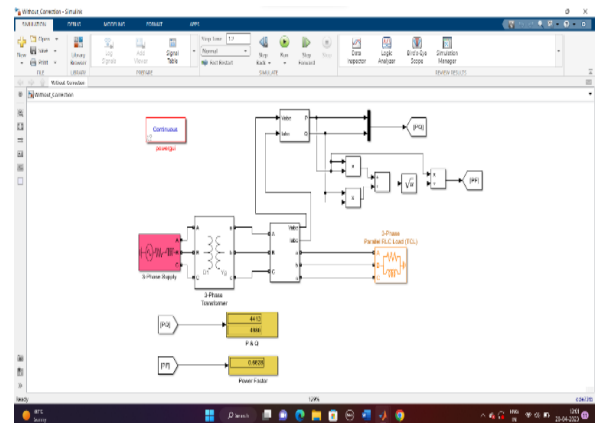

without correction is 0.6628 and the power factor correction with capacitor bank is 0.9038. the result are shown in the figure.

Fig.5 Simulation Model Without Capacitor Bank

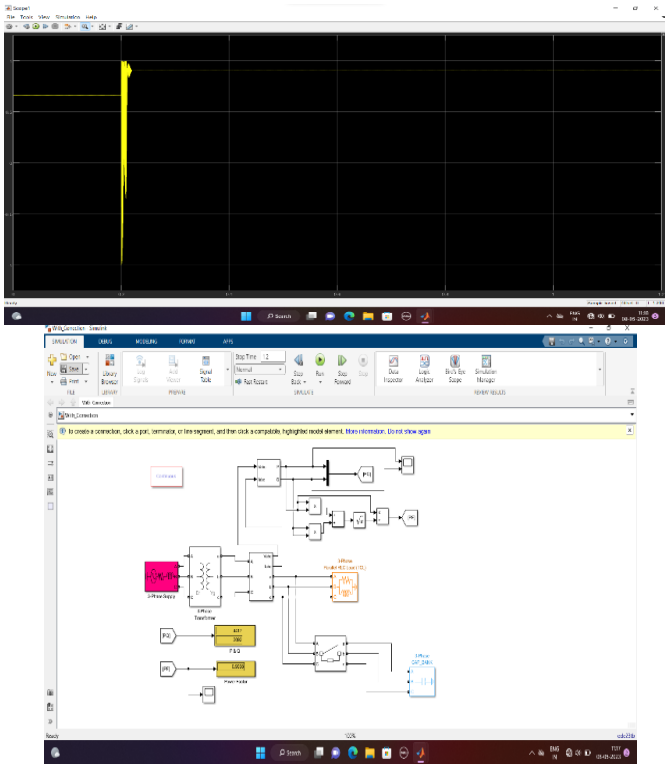

Fig.6 Simulation Model With Capacitor Bank

Fig.7 Waveform of Power Factor
Fig.8 Waveform of Real and Reactive Power
VIII CONCLUSION

A serious issue with electrical power delivery is power factor. The low power factor in some areas may have an impact on the overall quality of the power system. This project employs a capacitors bank and variable power factor correction to address the low power factor in the industrial region. When the systems power factor is below the desired level, an automation power factor correction system improves the low power factors. It is possible to achieve an excellent power quality by increasing the low power factor. Using MATLAB R2022b, a computer model



for a three-phase APFC system has been created. The power factor without and with a capacitor bank is examined and validated in the current work.

REFERENCE

- [1] using capacitors", International Journal of Engineering Trends & Technology (IJETT), Volume 4, Issued 7-July 2013.
- [2] Anant Kumar Tiwari, "Automatic Power Factor Correction Using Capacitor Bank," International Journal of Engineering Research and Applications, Volume 4, Issued February 2014.
- [3] Anaga Soman, Assistant Professor, Pranjali Sonje, Persuing M-Tech, Bharti Vidyapith University College of Engineering, Pune, Power Factor Correction Using PIC Microcontroller, "International Journal of Engineering and Innovative Technology (IJEIT), Volume 3, Issued 4 October 2003.
- [4] Tagwira, M. P., Design of an Automatic Power Factor Correction System, (2014)
- [5] AparnSarkar, UmeshHowase" Automatic Power Factor Correction by Continuou Monitoring", IJEIT, Issued 2008.
- [6] P.N.Engeti and R.Artinez,"A High Performance Single Phase Rectifier With Input Power Factor Correction," IEEE TRANSACTION ON POWER ELECTRONIC, Volume 11,No.3,IssuedMarch 2003.
- [7] McGill, T., Power Factor Correction, Eaton Corporation, 2007, pp. 24-26.
- [8] Shwehdi, M. H. & Sultan, M.R., Power Factor Correction Capacitors; Essential and Cautions, IEEE Power Engineering Society Summer Meeting, 2000, pp. 1317-1322
- [9] Saied, M. M., Optimal Power Factor Correction, IEEE Transaction on Power Systems, 1988, pp. 844-851.
- [10] Nidhi A. Ganatra1 Swati C. Chotaliya2 Prof Vishal N. Jogidas. (2017). "Minimizing Penalty in Industrial Power Consumption By Engaging APFC Unit". International Research Journal of Engineering and Technology (IRJET), 04(03 | Mar -2017), 04.
- [11] Pranjali Sonje, Pursuing MTech, Bharati Vidyapeeth. (October 2013). Power Factor Correction Using PIC Microcontroller. International Journal of Engineering and Innovative Technology (IJEIT) Volume 3, Issue 4, 12.
- [12] Chaudhary Deepak SGurjar Dharmesh S, Misra Sameer K, Nishad Rakesh S, Jigar A..(2018). Minimizing Penalty in Industries by Engaging Automatic Power Factor Correction Unit. International Journal of Innovative Research in Science, Engineering and Technology, 07 (2018), 08.
- [13] Rao U M,Vijaya M A, Venakata S S, Williams T J, Butter N G, "An Adapative Power Factor Controller For 3 Phase Induction Generations", IEEE Transaction on Power Apparatus and Systems, Volume: PAS 104,PP.1825-1831,1998,
- [14] Onar O C, Uzunoglu M, Alam M.S, "Dynamic Modeling, Design and Simulation of A Wind/Fuel Cell/Ultra-Capacitor-Based Hybrid Power Generation System", Journal of Power Sources 161 PP.707-722, 2006.
- [15] Suman Maiti, Chandan Chakraborty, "A New Instantaneous Reactive Power Based MRAS For Sensorless Induction Motor Drive", PP 1314-1326, 2010.
- [16] Sifat Shah, Rashid A, MKL Bhatti, "Direct Quadrate (D-Q) Modeling. Of 3 Phase Induction Motor Using MatLab / Simulink", Canadian Journal On Electrical and Electronics Engineering Vol. 3, No. 5, May 2012.

- [17] R. Gunaka, Regression and Kriging Analysis for Grid Power Factor Estimation, Lamer university, 2013, p. 98.