

Mitigation of Active, Reactive power loss and Overloading in a Restructured Powersystem using Series facts Device

N.Sambasivarao

Associate Professor and Head Department of EEE
NRI institute of Technology,agiripalli

Abstract— This paper presents a new method to mitigate Active,Reactive Power loss and Overloading in a Restructured Powersystem.The Increased power demand has forced the power system to operate very closer to its stability limits.So Transmission Overloading,Voltage instability and power loss problems are arise in the power system. These are very serious problems which cause damage to the power system.Overloading is a tough task in Deregulated power system.The above mentioned problems are reduced by incorporating Series Facts device in optimal location by Sensitivity analysis.The Simulation results were successfully tested on modified IEEE 5 bus system using Power world simulator 11.0.

Index Terms— Deregulated powersystem, Thyristor Controlled Series Capacitor (TCSC), Mitigation, Overloading, Total VAR Powerloss, Active ,Reactive power loss.

1 INTRODUCTION

In the recent year with the deregulation of the electricity market the traditional concepts and practice of the power system are changed.In this process the existing transmission lines are over loaded and lead to unstable system.Overloading may also due to transfer of cheap power from generator bus to load bus,this lead to the introduction of flexible ac transmission system(FACTS) such as Thyristor controlled series compensation(TCSC).This device control the power flow in the network And reduce the flow heavily loaded line there by resulting in an increase load ability low system losses improved stability of the network and reduced active, reactive power loss.

Because of the Economic considerations, Instalation of facts Controllers in all the buses or lines is impossible and Unnecessary.There are Several methods for finding the optimal location of FACTS devices in a power system.In [1],sensitivity approach is used to find the optimal location for placement of TCSC[6].The reduction of total system reactive Power loss method is one used to find optimal loation for placement of series FACTS device. Power flow index is used to find optimal location of FACTS device mitigation of overloading.The method firstly put all the busses in the orderby voltage reactive power sensitivity then choose the optimal location and appropriate capability of Thyristor controlled series capacitor (TCSC).

The issue of transmission overloading is more pronounced in deregulated and competitive markets and needs a special treatment.In this environment, independent system operator(ISO) has to relieve the overloading,so that the system is maintained in secure state. To mitigate overloading ISO can use mainly two types of techniques which are as follows:

- A. Cost free means : using sreies FACTS devices
- B. Re-dispatching the generation amounts

Among the above two methods cost free means do have advantage such as not touching economical matters, So GENCO and DISCO will not involved. FACTS devices,especially series FACTS devices like TCSC are considered one such technology that reduced the transmission overloading,powerloss (active,reactive) and allows better utilization of existing grid infrastructure,along with many benfits.

2. Thyristor Controlled Series Capacitor

The basic Thyristor -Controlled Series Capacitor scheme, proposed in 1986 by Vithayathil is shown in figure 1. It consists of the series compensating capacitor shunted by a Thyristor-controlled Reactor. In a practical TCSC implementation, Several such basic compensators may be connected in series to obtain the desired voltage rating and operating characteristics.

N.Sambasiva Rao received M. Tech in Electrical Power Engineering and B.Tech degree in Electrical & Electronics Engineering from JNTU Hyderabad, India.. He is perusing his Ph.D from JNTU, Hyderabad, India.

Fig 1. Equivalent circuit of TCSC

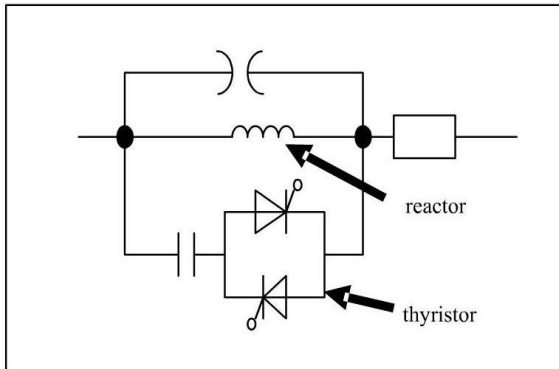

2.1 Transmission line modeling with TCSC

The series impedance of a high voltage transmission line is usually inductive, with only 5 to 10 percentage of resistance. This provides convenient condition to control the steady state impedance of transmission line by adding both a Thyristor Controlled Series Capacitor (TCSC) and a Thyristor Controlled Series Reactor.

$$P_{ij}^c Q_{ij}^c P_{ji}^c Q_{ji}^c P_{ic} Q_{ic} P_{jc} Q_{jc}$$

Determined from [7] Method.

A General equivalent circuit of TCSC injected in transmission line is shown in fig2.

Fig 2. Injection Model of TCSC

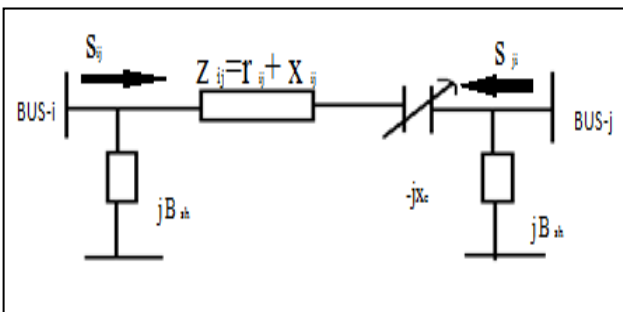

3. DEVICE PLACEMENT USING LOSS SENSITIVITY INDEX METHOD

The objective of the device placement may be reduction in the real power loss of a particular line, reduction in the total system real power loss, reduction in the total reactive power loss and reduction in the overloading of the system. Loss sensitivity index is method based on the sensitivity of total system active and reactive power loss with respect to control variable of the FACT device.

The power loss sensitivity index with respect to this control variable can be formulated as

$$a_{ij} = \frac{\partial Q_L}{\partial X_{ij}}$$

Loss sensitivity with respect to TCSC

$$\frac{\partial Q_L}{\partial X_{ij}} = \left[v_i^2 + v_j^2 - 2v_i v_j \cos(\delta_i - \delta_j) \right] \frac{R_{ij}^2 - X_{ij}^2}{(R_{ij}^2 + X_{ij}^2)^2}$$

$$Q_L = \sum_{i=1}^n \sum_{j=1}^n \left[\gamma_{ij} (P_i P_j + Q_i Q_j) + \epsilon_{ij} (Q_j P_i - P_j Q_i) \right]$$

Where α, β, γ and ϵ are loss coefficients computed from the elements of the bus impedance matrix and the bus voltage defined as :

$$\alpha_{ij} = \frac{\gamma_{ij}}{V_i V_j} \cos(\delta_i - \delta_j)$$

$$\beta_{ij} = \frac{\gamma_{ij}}{V_i V_j} \sin(\delta_i - \delta_j)$$

$$\gamma_{ij} = \frac{X_{ij}}{V_i V_j} \cos(\delta_i - \delta_j)$$

$$\epsilon_{ij} = \frac{X_{ij}}{V_i V_j} \sin(\delta_i - \delta_j)$$

4. Criteria for Optimal placement for TCSC

The FACTS device should be placed on the most sensitivity bus or line. For the TCSC the location is the line with most positive sensitivity index. The TCSC should be placed on the line having most positive loss sensitivity index.

5. Simulation results for modified IEEE 5-bus system.

Test results are obtained by considering practical IEEE 5 - bus system. OPF solution is obtained on the system to determine the optimum generation schedule than satisfied the objective of minimizing the losses from the desire transactions and controlling of voltage magnitude. Here the sensitive index for TCSC has been calculated for the placement of FACTS device. The FACTS device placement method known as sensitivity index has been tested on IEEE 5- bus system.

Figure.3 Shows the single line diagram of IEEE 5-bus system

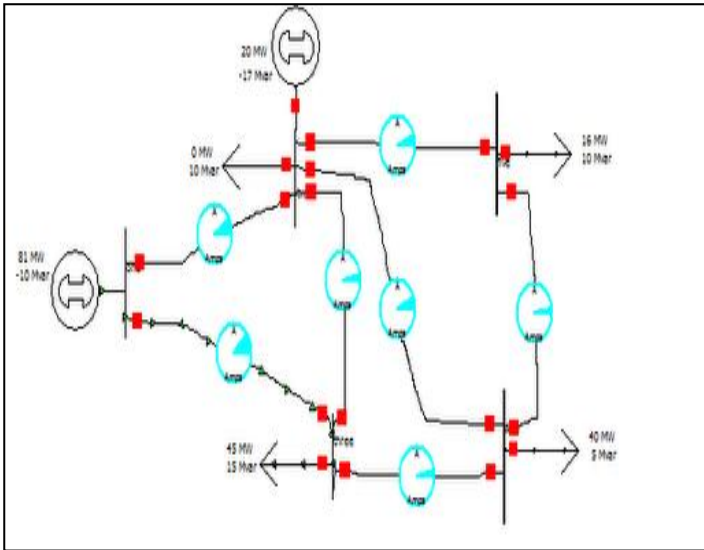
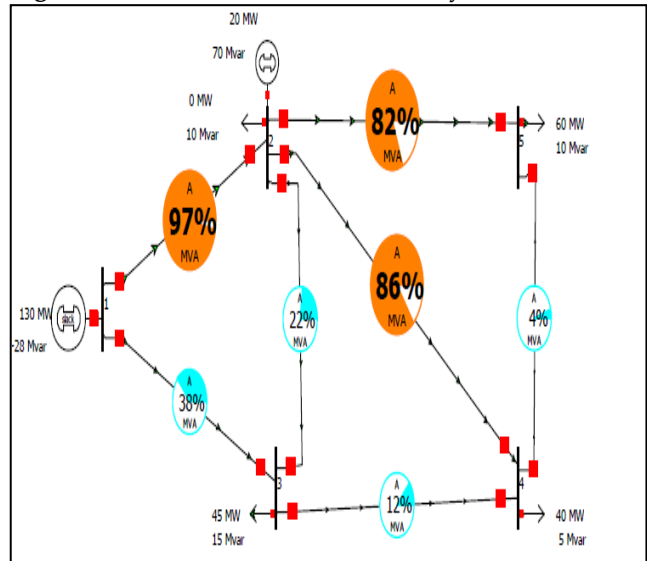

Fig 4 Shows the modified IEEE 5- bus system with out TCSC



The sensitivity of 5-bus system with out TCSC is given in the table below.

Table 1: sensitivity Index

Lines	From bus	To bus	Sensitivity Index
1	1	2	-7.759671
2	1	3	-0.120364
3	2	3	-0.303177
4	2	4	-1.145739
5	2	5	-1.69700
6	3	4	-32.19711
7	4	5	-0.026715

From the above table 1, the lines 1-3 and 4-5 have the most positive sensitivity factors. So these are the best locations for placement of TCSC to reduce over loading in the network. By placing TCSC in the line 1-3, the overloading can be mitigated[1].These location offer best results in terms of increase in active power generation with mitigation of active and reactive powerloss and improvement of voltage profile.

Fig .4 Shows the transimtion line flows without TCSC . It is observed that the lines 1-2, 2-4 and 2-5 are over loaded compared to other lines.

The percentage lodability values for modified IEEE 5-bus System is tabulated below.

Table2: Optimum power flow result with out TCSC

LINES	FROM BUS	TO BUS	LODABILITY [%]
1	1	2	96.9
2	1	3	37.6
3	2	3	22.4
4	2	4	86
5	2	5	82.9
6	3	4	11.8
7	4	5	4.1

From the above table 2, the maximum lodable lines are 1-2, 2-4and 2-5. Due the Increased loading these lines are over-loaded. So by using TCSC, overloading is going to be reduced.

Table 3: Optimum power flow solution on 5-bus system with out TCSC

Quantity	Values without TCSC
Active power loss	9.086
Reactive Power loss	36.99

Table 4: Voltage profile without TCSC

Bus no	Voltage Magnitude Without TCSC
1	1.06
2	1
3	1.0061
4	0.9879
5	0.9815

Fig 5. Voltage profile without TCSC

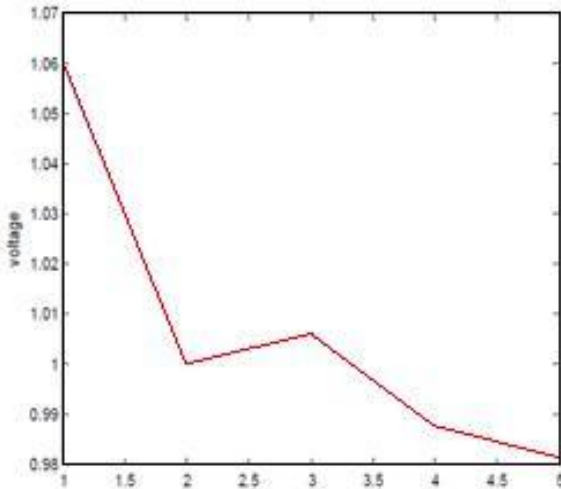

Table 3 shows result obtained on 5-bus system for Active and Reactive power loss without TCSC. Table 4 shows voltage magnitudes at each bus with out placement of TCSC. The results obtained on 5-bus system indicate that in order to maintain the voltage magnitude at main at 1.1p.u.

5.1 Simulation results on IEEE 5-bus system with TCSC

From the table 1 , the maximum Loadable lines are 1-2,2-4 and 2-5. From table 2 , the lines 1-3 and 4-5 have the most positive sensitivity factors. From the above anolosis these are the best location for placement of TCSC . By placing the TCSC in the line 1-3, the overloading in the system is mitigated which is shown in fig 6

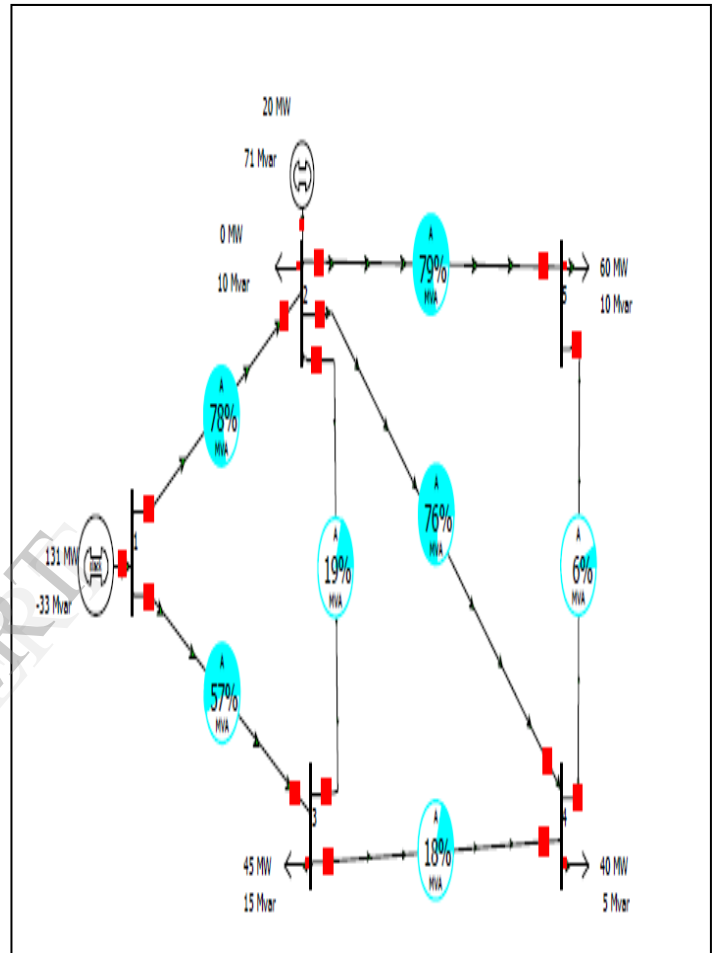

Fig 6 Shows the modified IEEE 5- bus system With TCSC (Overloading mitigation by TCSC)

It is observed that after placing TCSC the over loading in the line is reduced. The objective is to mitigate power loss ,overloading and improving voltage profile.TCSC is modeled as an adjustable series reactance which is a function of TCSC.By incorporating TCSC not only reduce the powerloss also improves the voltage profile shown in table:7.It is observed that optimal power flow solution changes little compared with the base optimal power flow shown in table:6 when TCSC is used.The Table6 shows Loadability of each line when TCSC is placed in the line 1-3 .

Table5: Optimum power flow result with TCSC (65% Comp)

Lines	From Bus	To Bus	Lodability [%]
1	1	2	74.42
2	1	3	56.12
3	2	3	9.03
4	2	4	28.74
5	2	5	55.45
6	3	4	17.35
7	4	5	5.86

From the above table 4 , by incorporating TCSC in the Line 1-3, then overloading is mitigated.

Table 6: Optimum power flow solution on 5-bus system with TCSC

Quantity	Values with TCSC
Active power loss	8.963
Reactive Power loss	36.99

Fig 7.Voltage profile with TCSC

Bus no	Voltage Magnitude With TCSC
1	1.0600
2	1.0000
3	1.0197
4	1.0022
5	0.9647

Fig 7.Voltage profile with TCSC

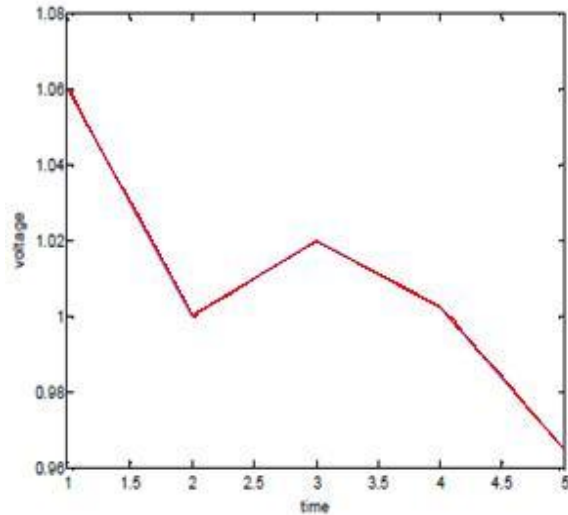

The comprision of power flows with and without TCSC is shown as

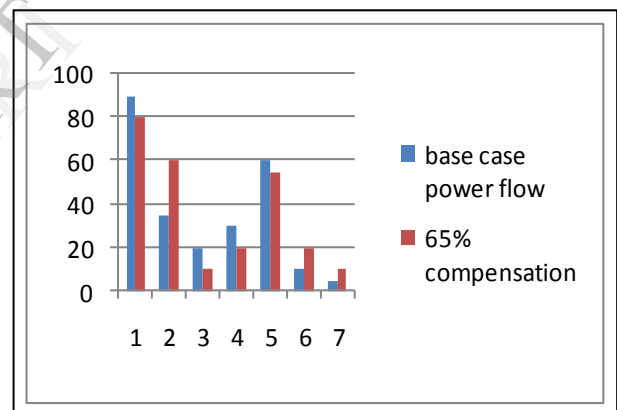

Chart1:comprision of power flows(MW) with and without TCSC

6 Conclusions:

Mitigation of overloading, power loss is an important issue in deregulated power system. FACTS devices such as TCSC by controlling the power flow in the network can help to reduce flows in overloaded lines. Because of the considerable costs of FACTS devices, It is important to obtain optimal location for placement of these devices. The results presented in this paper show that sensitivity index along with TCSC. The effect of TCSC on line outage in order to mitigate overloading has also been studied. It can be observed from the setting the installed TCSC.

ACKNOWLEDGEMENTS

We, the authors are very grateful to the **Chairman** of NRI group of Institutions **Dr. R. Venkat Rao** and Principal of NRI Institute of Technology **Dr. C. Naga Bhaskar**. Without their assistantship the work could not be completed.

REFERENCES:

[1] L. Rajalakshmi, M. V. Suganyadevi, S. Parameswari, "Congestion Management in Deregulated Power System by Locating Series FACTS Devices," International journal of Computer applications, Vol. 13, pp 0975-8887, Jan 2011.

[2] B. Likitha, J. Srinivasa Rao, J. Amarnath "Sensitivity Approach for Efficient Location of TCSC in a Deregulated Electricity Market," IOSR Journal of Engineering, ISSN: 2250-3021, Vol. 2, pp 09-15, June 2012.

[3] A. R. Abhyankar, Prof. S. A. Khaparde "Introduction to Deregulation in Power Industry," IIT Bombay.

[4] K. Vijayakumar, "Optimal location of FACTS Devices for Congestion Management in Deregulated Power System," International Journal of Computer Applications, Vol. 16, pp. 0975-8887, Feb 2011.

[5] J. Namaratha Manohar, Amarnath Jinka, V. Poornachandra Rao, "Optimization of Loss Minimization Using FACTS in Deregulated Power System," Innovative System Design and Engineering, Vol. 3, ISSN 2222-1727, 2012.

[6] Mrinal Ranjan, B. Vedit, "Optimal Location of FACTS Devices in a Power System by Means of Sensitivity Analysis" Science Road Publishing Corporation- Trends in Electrical and Computer Engineering TECE 1(1) 1-9, 2011.

[7] J. Srinivasarao, Dr. Amarnath "Transmission Congestion Management comparative studies in Rstructured Power System," International Journal of scientific & Engineering Research, Volume 4, Issue 8, August-2013.

[8] Harry Singh, Shangyou Hao, Alex Papalexopoulos, "Transmission Congestion Management in Competitive Electricity markets" IEEE Transactions on power systems, Vol. 13, No. 2, May 1998.

[9] Naresh Acharya, N. Mithulananthan, "Locating series FACTS devices for congestion management in deregulated markets" Electric Power systems research 77(2007) 352-360.

[10] Srinivasa Rao Pudi, S. C. Srivastava, "Optimal Placement of TCSC Based on A Sensitivity Approach for Congestion Management," Fifteenth National Power System Conference, IIT Bombay, Dec 2008

[11] D. J. Gotham and G. T. Heydt, 1998, Power flow control and power flow studies for system with FACTS devices IEEE Trans, power system, and Vol. 13 no. 1.

[12] G. H. Hingorani, 1993 Flexible AC transmission system IEEE spectrum Apr 1993.

[13] H. Ambriz-Perez et. al., 2000 and C. Fuerte-Esquivel Advanced SVC models for Newton-Raphson load flow and Newton optimal power flow studies IEEE Power Transactions on Power Systems vol. 15 pp. 129-136.

[14] H. C. Leung and T. S. Chung, 2000 Optimal power flow with a versatile FACTS controller by Genetic Algorithm approach Proceeding of the 5th international conference on Advances in power system control, operation and management APSCOM pp. 178-183.

[15] W. O. Stadlin and D. L. Fletcher, 1982 voltage versus Reactive current model for Dispatch and control IEEE Transactions on Power Apparatus and Systems vol. PAS-101 no. 10 pp. 3751-3758 Oct 1982.

[16] Preecha Preedavichit and S. C. Srivastava, 1995 Optimal reactive power dispatch considering FACTS devices Electrical power research, vol. 48, pp. 251-257.

[17] N. G. Hingorani and L. Gyugyi, 2000 Understanding FACTS: Concepts and technology of Flexible AC Transmission Systems, IEEE Press, ISBN 0-7803-3455-8.

Author Biography



N. Sambasiva Rao received the B.Tech degree in Electrical & Electronics Engineering and M. Tech in Electrical Power Engineering from JNTU Hyderabad, India. He has 12 years experience in teaching. He is pursuing his Ph.D from JNTU, Hyderabad, India. He published a 7 research papers in various International Journals and 2 research papers in National Conferences. He is the Member of International Association of Engineers (IAENG) and Life member of ISTE.

He is currently working as Associate Professor and Head of the department in Electrical & Electronics Engineering at NRI Institute of Technology, Agiripalli, India. He got "**Best Achiever award of Andhra Pradesh**" by NCERT, New Delhi, India. His Areas of interest include Electrical Machines, control Systems and power System Protection.