

# Modeling And Control of Grid-Connected Hybrid Photovoltaic/Battery Distributed Generation System

**B. K. Prusty<sup>1</sup>**

Sr. Lecturer Electrical Engineering Department

**Seemanta Engineering College**

Mayurbhanj, Odisha

**Dr S M Ali<sup>2</sup>**

Prof. School of Electrical Engineering  
KIIT University

**D. K. Sahoo<sup>3</sup>**

**Seemanta Engineering College**

Mayurbhanj, Odisha

## Abstract

Photovoltaic (PV) generation is the technique which uses photovoltaic cell to convert solar energy into electrical energy. Now a day, PV generation is developing increasingly fast as a renewable energy source. This paper deals with the power control and transient model of grid connected PV/battery hybrid generation. The disadvantage in the PV generation is that PV generation is intermittent for depending on weather conditions. Thus to outcome from this difficulty battery energy storage is necessary to help in order to get stable and reliable output from the PV generation systems for loads. Here PV array is firstly connected to the common dc bus by a bi-directional DC/DC converter and then connected to a common grid by a common dc/ac inverter. In this paper also includes maximum power tracking (MPPT) which helps pv array to generate the maximum power to the grid and the battery.

Key Words: Battery energy storage system (BEES), photovoltaic generation, grid interface, maximum power point tracking, modeling.

## 1. Introduction:

As energy demands around the world increase, the need for renewable energy source that will not harm the environment has been increased. Some projections indicate that the global energy demand will triple by 2050. Renewable energy sources currently supply somewhere between 15% and 20% of the total world energy demand. Photovoltaic (PV) generation is the technique which uses photovoltaic cell to convert solar energy to electric energy. Photovoltaic energy is assuming increasingly important as a renewable energy source because of its distinctive advantages, such as simple configuration, easy allocation, free of pollution, low maintenance cost and among others [1,2] etc. However, the disadvantage is that

photovoltaic generation is intermittent, depending upon weather conditions. Thus, energy storage element is necessary to help get stable and reliable power from PV system for loads or utility grid, and thus improve both steady and dynamic behaviors of the whole generation system. Because of its mature technology, low cost and high efficiency, battery energy storage system (BESS) is used widely in distribution generation technology. BESS can be integrated into PV generation system to form a hybrid PV/Battery generation system, which can be more stable and reliable. An integral grid-connected PV Battery generation system is composed of PV array, battery, power electronic converters, filters, controllers, local loads and utility grid.

## 2. PV Array:

Various equivalent circuit models of a PV cell have been proposed [3, 4, 5]. For obtaining high power, numerous PV cells are connected in series and parallel circuits on a panel, which is a PV module. A PV array is defined as a group of several modules electrically connected in series-parallel combinations to generate the required current and voltage.

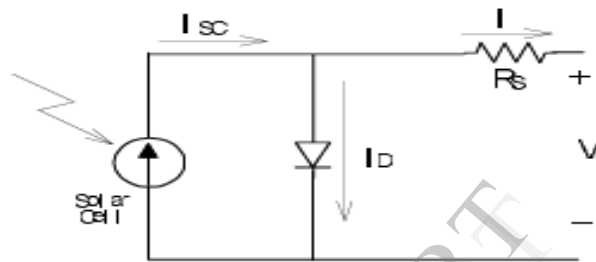

Figure 1, Equivalent circuit of a PV module

Fig. 1 shows a simplified equivalent circuit model of a PV module used in the study, which consists of a current source in parallel with a diode and in series with a series resistor. Based on the PV module model in Fig. 3, behavior of a PV array with  $N_S \times N_P$  modules may be described by equation shown below. Parameters for the PV module model may be obtained from manufacturer's data sheet in part and by some deduction methods in part [6].

$$I_A = N_P I_{SC} - N_P I_0 \left( \exp \left[ \frac{V_A + I_A R_S}{n N_S V_T} \right] - 1 \right)$$

Where  $I_A$  = output current of PV array [A]  
 $I_{SC}$  = short circuit current of PV module [A]  
 $I_0$  = diode saturation current [A]  
 $V_A$  = terminal voltage of PV array [V]  
 $R_S$  = series resistance [ $\Omega$ ]  
 $n$  = ideal constant of diode (1~2)  
 $V_T$  = thermal potential of PV module [V]

Use MATLAB/Simulink to implement the model of PV array, shown in figure 2.

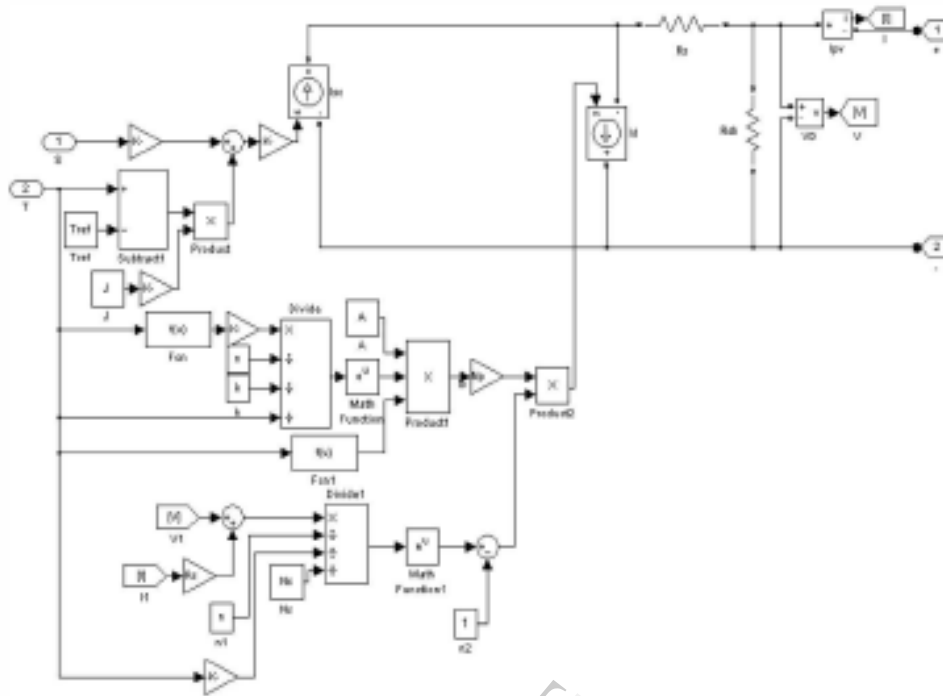

Figure 2, The model of PV array in MATLAB/Simulink  
 With different temperatures and solar radiations, output characteristics of PV array are simulated as figure 3 and figure 4.

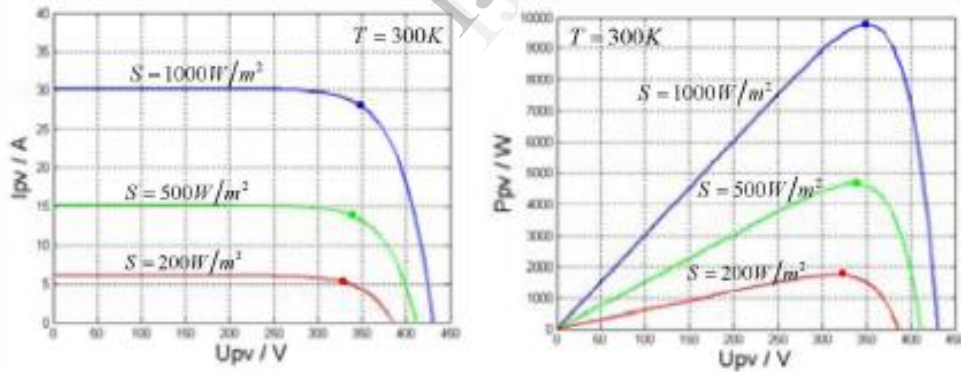

Figure 3, Characteristic curves of the PV array with different solar irradiances .

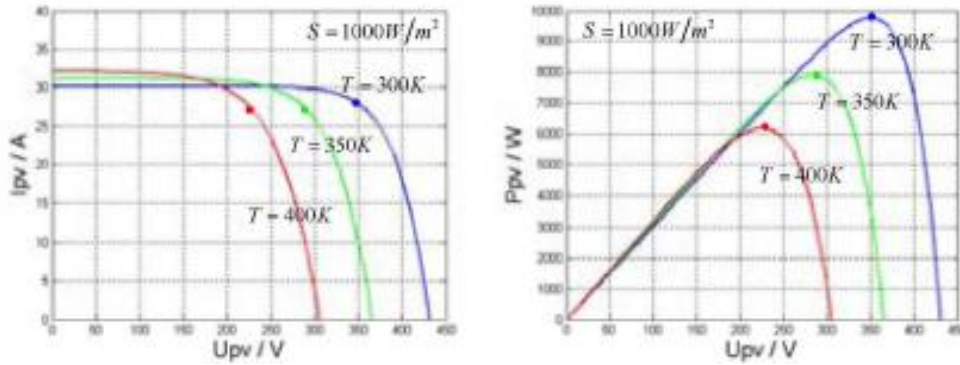

Figure 4, Characteristic curves of the PV array with different cell temperatures.

As shown in figure 3 and 4, PV array has nonlinear voltage-current characteristics, and there is only one unique operating point for a PV generation system with a maximum output power under a particular environmental condition.

### 3. Battery Model

Battery model can usually be divided into experimental model, electrochemical model and equivalent circuit model. The equivalent circuit model is most suitable for dynamic simulation. Based on Shephred battery model, reference [7] presents a generic battery model for dynamic simulation, which assumes that the battery is composed of a controlled-voltage source and a series resistance, shown as figure 5. This generic battery model considers the state of charge (SOC) as the only state variable.

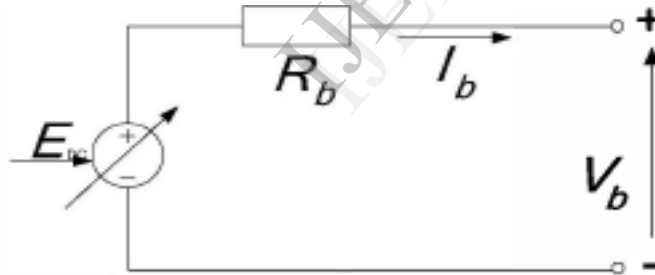

Figure 5, A generic battery model

The expression of the controlled voltage source is :-

$$E = E_o - K \frac{Q}{Q - \int i_b dt} + A \exp \left( -B \cdot \int i_b dt \right)$$

where, E is no-load voltage (V); E<sub>o</sub> is battery constant voltage (V); K is polarization voltage (V); Q is battery capacity (Ah); A is exponential zone amplitude (V); B is exponential zone time constant inverse (Ah<sup>-1</sup>).

### 4. Grid-connected PV/Battery Generation System

Figure 6 is the configuration of the grid-connected PV /Battery generation system. PV array and battery are connected to the common dc bus via a DC/DC converter respectively, and then interconnected to the ac grid via a common DC/AC inverter. Battery energy storage can charge and discharge to help balance the power between PV generation and loads demand. When the generation exceeds the demand, PV array will charge the battery to store the extra power, meanwhile, when the generation is less than the demand, the battery will discharge the stored power to supply loads. Each of PV system, battery energy storage system and the inverter has its independent control objective, and by controlling each part, the entire system is operating safely.

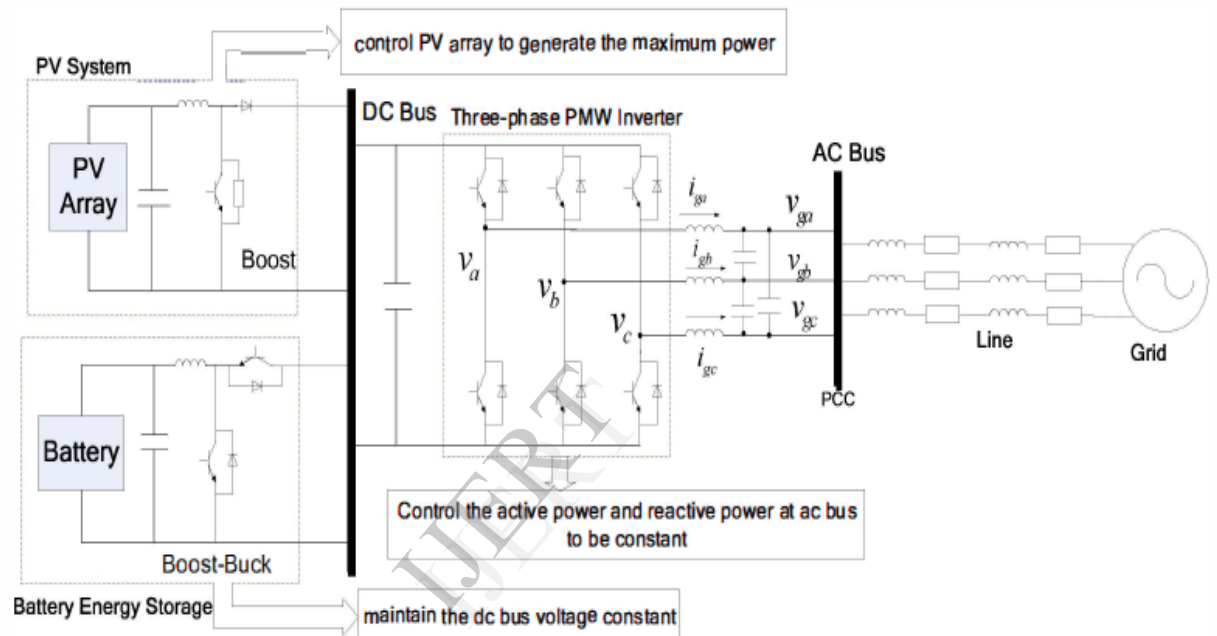

Figure 6, Configuration of the grid-connected hybrid PV /Battery generation system.

#### 4.1 PV Side Power Control And Maximum Power Point Tracking

The PV array must operate electrically at a certain voltage which corresponds to the maximum power point under the given operating conditions, i.e. temperature and irradiance. To do this, a maximum power point tracking (MPPT) technique should be applied. Various MPPT techniques have been proposed and implemented, e.g. look-up table methods, perturbation and observation (P & O) methods and computational methods [8-9-10].

#### 4.2 Boost circuit and its control

For two-stage PV generation system, boost chopper circuit is always used as the DC/DC converter. Since the output voltage of PV cell is low, the use of boost circuit will enable low-voltage PV array to be used, as a result, the total cost will be reduced. A capacitor is generally connected between PV array and the boost circuit, which is used to reduce high frequency harmonics. Figure 7 is the configuration of the boost circuit and its control system.

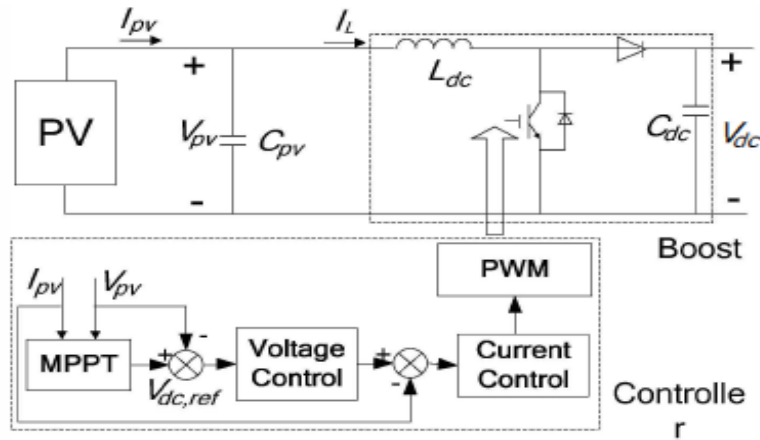

Figure 7, Boost circuit and its control

### 4.3 Battery energy storage system

Battery energy storage system (BESS) is composed of a battery bank, a bi-directional DC/DC converter and control system[11]. The system should be able to operating in two directions: the battery can be charged to store the extra energy and also can discharge the energy to loads.

In the paper, BESS is typically connected to the dc bus through a bi-directional DC/DC converter, as shown in figure 8. The utility grid is considered as a backup source and the battery bank serves as a short-duration power source to meet the load demands which cannot be fully met by the PV system, particularly during fluctuations of the solar or transient periods.

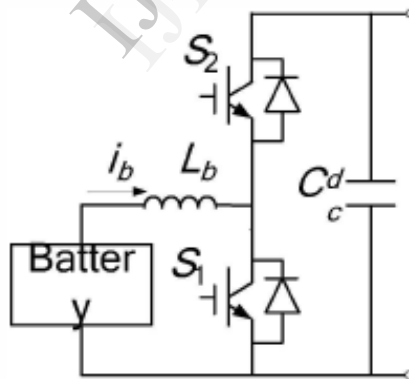

Figure 8. The bi-directional DC/DC converter.

The primary objective of the battery converter is to maintain the common dc link voltage constant. In this way, no matter the battery is charging or discharging, the voltage of the dc bus can be stable and thus the ripple in the capacitor voltage is much less. When charging, switch  $S_1$  is activated and the converter works as a boost circuit. otherwise. When discharging, switch  $S_2$  is activated and the converter works as a buck circuit.

### 4.4 Control of the grid-connected inverter

PV array and the battery are connected to the ac grid via a common DC/AC inverter. The inverter is used in current control method with PWM switching mechanism to make the

inductance current track the sinusoidal reference current command closely and obtain a low THD injected current. The control strategy mainly consists of two cascaded loops, namely a fast internal current loop and an external voltage loop. The proposed multi-level control scheme is based on the concept of instantaneous power on the synchronous-rotating dq reference frame.

The internal control can be depicted as figure 9.

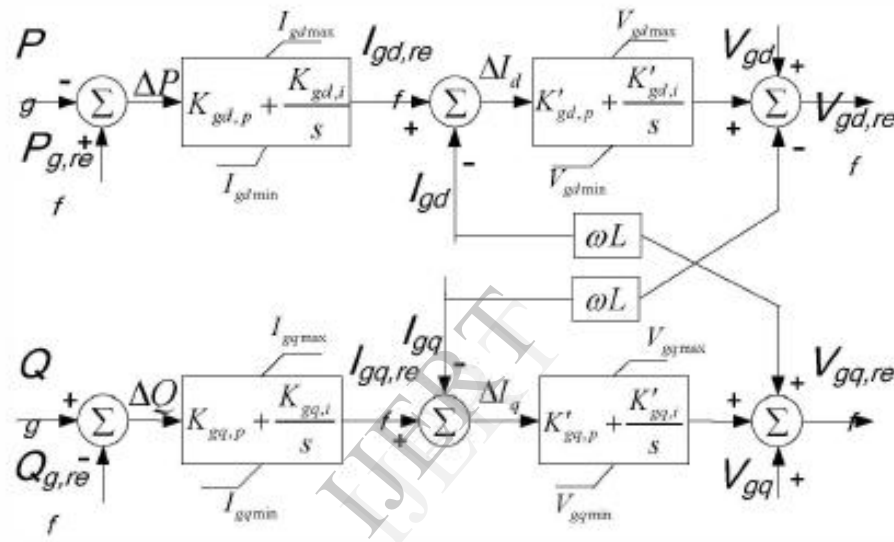

Figure 9, Control scheme of the grid-side inverter

## 5. Simulation Study

Based on the above models and control methods, the grid-connected hybrid PV /Battery generation system can be implemented in MATLAB/Simulink, as shown in figure 10.

In this paper, three simulation cases are studied, namely a, steady operation, when the generation of PV array is equal to the load demands; b, changes of solar irradiance, when the generation of PV array is not equal to the load demands and the battery will charge/discharge to store/release energy.

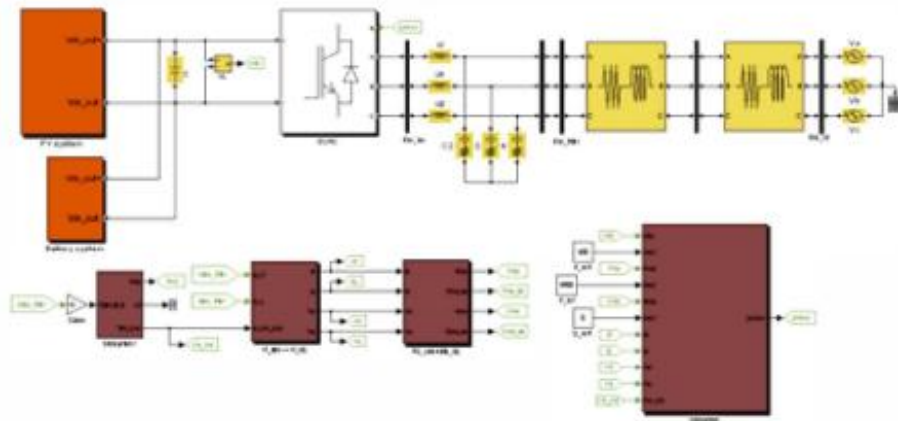
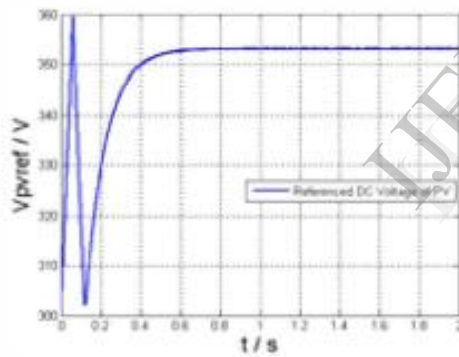
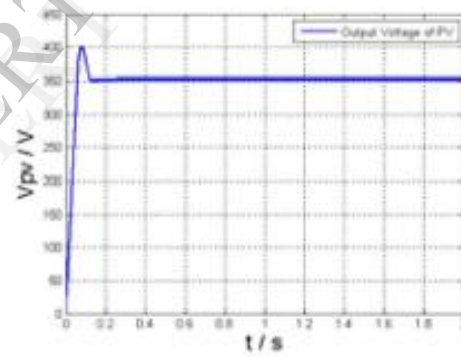

Figure 10, Simulation model of the hybrid generation system



(a) DC reference voltage



(b) Output voltage of PV array

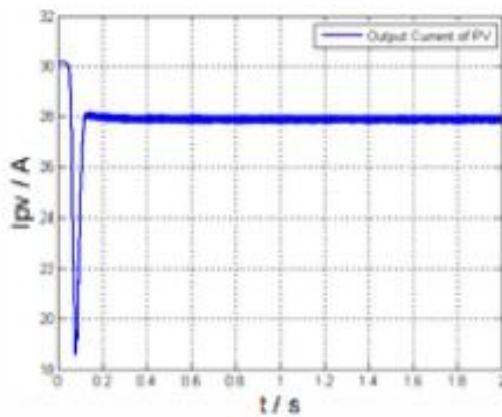

(c) Output current of PV array

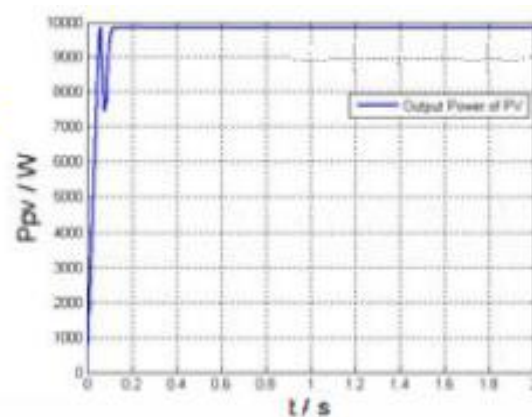

(d) Output power of PV array



## 6. Conclusions

In this paper, a grid-connected hybrid PV /Battery generation system is studied. In order to convert the solar energy efficiently, the maximum power point of the PV array should be tracked to ensure the PV array to generate most power to utility grid. Modified variable-step P&O method can change the perturbation as the real operation point changes, consequently, both of the tracking speed and algorithm accuracy are satisfied. When solar irradiance or temperature fluctuates, PV generation will change as a result. Battery can be charged or discharge to maintain the power balance between PV generation and the demands, and thus improve the stability of the entire system.

## References

1. Darren M. Bagnall, Matt Boreland, "Photovoltaic technologies", Energy Policy, Vol 36, pp. 4390-4396, 2008.
2. C.Hua,C.Shen,"Comparative Study of Peak Power Tracking Technique for solar storage system, "IEEE Applied power electronics conference and Exposition proceeding,Vol.2,Feb.1998.
3. Mohammad A. S. Masoum, Hooman Dehbonei, and Ewald F. Fuchs,"Theoretical and Explanation Analysis of Photovoltaic Systems With Voltage- and Current-Based Maximum Power-Point Tracking", IEEE Trans. on Energy Conversion, Vol. 17, No. 4, pp. 514-522, December 2002.
4. L Zhang, A Al-Amoudi, Yunfei Bai, "Real-time Maximum Power Point Tracking for Grid-Connected Photovoltaic Systems", Power Electronics and Variable Speed Drives, 18-19 September 2000, Conference Publication No. 475.
5. J. A. Gow, C. D. Manning, "Development of a photovoltaic array model for use in power-electronics simulation studies", IEE Proceedings-Electric Power Applications, Vol 146, No. 2, pp. 193-200, 1999.
6. Minwon Park and In-Keun Yu, "A Novel Real-Time Simulation Technique of Photovoltaic Generation Systems Using RTDS", IEEE Trans. On Energy Conversion, Vol. 19, No. 1, pp. 164-169, March 2004.
7. Chan H L, Sutanto D, "A new battery model for use with battery energy storage systems and electric vehicles power systems", Power Engineering Society Winter Meeting, pp. 470-475,2000.
8. M.G. Molina, Domingo H. Pontoriero, P.E. Mercado, "An Efficient Maximum Power Point Tracking Controller for Grid-connected Photovoltaic Energy Conversion System", Electronica de Potencia, Vol 12, No. 2, pp. 147-154,2007.
9. C.Hua and CShen, "Study of Maximum Power Tracking Technique and control of DC/DC CONVERTER FOR Photovoltaic system",IEEE Computer soc.press,New York,USA,1998

10. Trishan Eswar, Patrick L, Chapman, "Comparison of Photovoltaic Array Maximum Power Point Tracking Techniques", IEEE Transaction on Energy Conversion, Vol 22, No.2, pp. 439-499, 2007.

11. Jingang Han, Tianhao Tang, Yao Xu, et al, "Design of storage system for a hybrid renewable power system", 2009 2nd Conference on Power Electronics and Intelligent Transportation System, Vol 2, pp. 67-70, 2009.

IJERT