

# MPPT Based Solar PV System For 3- $\Phi$ Grid Connected IGBT Inverter System Using POWER-GUI Environment

Sunil Kumar Mahapatro

*Asst. Prof., E.E.E. dept.*

*Gandhi Institute For Technology*

*Bhubaneswar, Odisha, India*

**Abstract**—The paper mainly to develop a grid connected PV system with MPPT function using mat lab environment & predicts the behavior of real PV system. The model contained a detailed representation of the main component of the system that are solar array, MPPT controller, PWM generator and PLL technique. In order to extract the maximum amount of from the photovoltaic generator, we propose an intelligent control method for the maximum power point tracking (MPPT) of a photovoltaic system under variable temperature and insulation conditions. The outer DC voltage control loop is to keep the input DC voltage stable, and the inner grid current control loop is to ensure that the output current has the same frequency and phase angle as the grid voltage. PLL technique used in the control circuit of the inverter ensures the tracking accuracy of the output current.

**Index Terms**—DG, MPPT, Solar Array, PWM Generator, PLL

## I. INTRODUCTION

With electricity load increased, transmission capacity of long-distance transmission line is increasing, and the dependence of terminal power grid on foreign power grid is also increasing, it is necessary for us to build certain capacity power plants at terminal power grid and load centers, so as to reduce the large power transmission and transfer, to reduce the losses of transmission & distribution, to support the local power grid, to enhance system stability. Therefore under a large grid pattern in the country, distributed generation (DG) should be developed properly[1]. Solar energy is a renewable, inexhaustible and ultimate source of energy. If used in a proper way, it has a capacity to fulfill numerous energy needs of the world. The power from the sun intercepted by earth is approximately  $1.8 \times 10^{11}$  MW [2]. However, the disadvantage is that photovoltaic generation is intermittent, depending upon weather conditions. Thus, the MPPT makes the PV system providing its maximum power and that energy storage element is necessary to help get stable and reliable power from PV system for both loads and utility grid, and thus improve both steady and dynamic behaviors of the whole generation system.

To maximize a PV system's output power, continuously tracking the maximum power point of the system is necessary. Distributed generation systems and their interconnection should meet certain requirements and specifications when interconnecting

with existing electric power systems (EPS) . For an inverter-based distributed generator, the power quality largely depends on the inverter controller's performance. Pulse width modulation (PWM) is the most popular control technique for grid-connected inverters. As compared with the open loop voltage PWM converters, the current-controlled PWM has several advantages such as fast dynamic response, inherent over-current protection, good dc link utilization, peak current protection etc [3].

The working function of PLL is a control system that produces an output signal whose phase is related to phase of an input reference signal. It consists of variable frequency oscillator and a phase detector. The circuits compares the phase of input signal with the phase of signal derived from its output oscillator and adjusts the frequency of its oscillator to keep the phase matched. The proposed model of the entire components and control system are all simulated in Mat lab/Simulink Software. The case are simulated only on steady states, and all simulation results have verified the validity of models and effectiveness of control methods. The paper is organized as follows – Modeling of PV array are given in section II. MPPT algorithm are described in section III. Phase locked loop are described in section IV. PWM generator model are given in section V .Section. VI dedicated to working principle of grid connected PV system, section VII dedicated to simulation result and followed by conclusion in Section VIII and references in section IX

## II. MODELING OF PV ARRAY

### A. Modeling of PV array

A typical PV cell produces less than 2W at 0.5V approximately; the cells are connected in series-parallel configuration on a module to produce high power. A PV array is a group of several PV modules which are electrically connected in series and parallel circuits to generate the required current and voltage. For  $N_s$  cells connected in series and  $N_p$  cells connected in parallel. Then equivalent equation can be given as

$$I = I_{pv} N_p - I_s N_p \left[ \exp \left( \frac{q(V + IR_s)}{N_s akT_c} \right) - 1 \right] - \frac{(V + IR_s)}{R_{sh}}$$

(1)

The equivalent circuit for the solar array in which the modules are arranged with  $N_{pp}$  parallel and  $N_{ss}$  series as is shown in figure

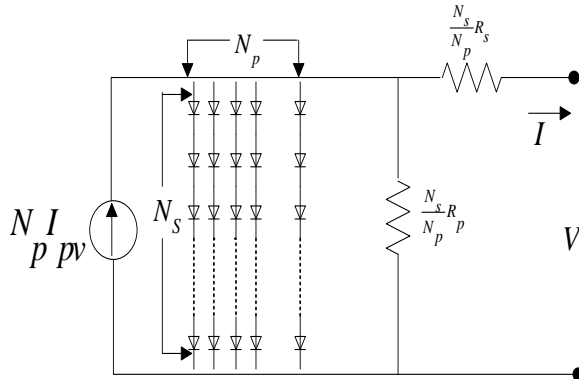

Fig 1. General Equivalent circuits Model of generalized PV array  
The terminal equation for the current and voltage of the array becomes as follows

$$I = I_{ph} N_{pp} - I_s N_{pp} \left[ \exp \left( \frac{q \left( \frac{V}{N_{pp}} + \frac{IR_s}{N_{ss}} \right)}{akT_c} \right) - 1 \right] - \frac{\left( \frac{N_{pp} V}{N_{ss}} + IR_s \right)}{R_{sh}}$$

(2)

**B. Simulink Model of PV array**

We can simulate the PV array with an equivalent circuit model based on PV model shown in Fig.2

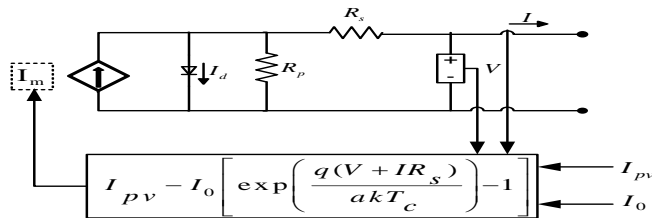

Fig 2. Photovoltaic array model with a current controlled source, equivalent resistor

**C. Simulation result of PV array**

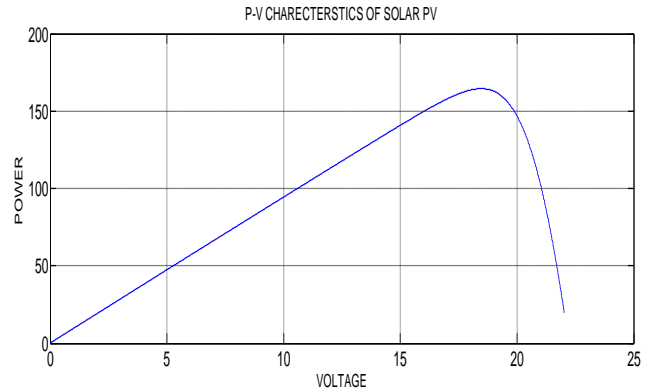

Fig 3. P-V characteristics of solar PV

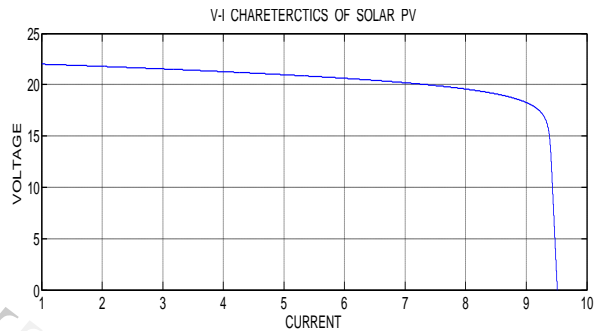

Fig 4. V-I characteristics of solar PV

The output of Simulink model is shows first the P-V characteristics of PV module and then V-I characteristics, reference to the key specifications of the NA-901 module illustrated in table 1 , the results of Simulink PV module show the excellent correspondence to the model

TABLE I. SOLAR PANNEL SPECIFICATION

Temperature	T	25	C°
Maximum Power	P <sub>MAX</sub>	131	W <sub>p</sub>
Open circuit voltage	V	23	V <sub>OC</sub>
Short circuit current	I	7.2	I <sub>SC</sub>

### III.MPPT ALGORITHM

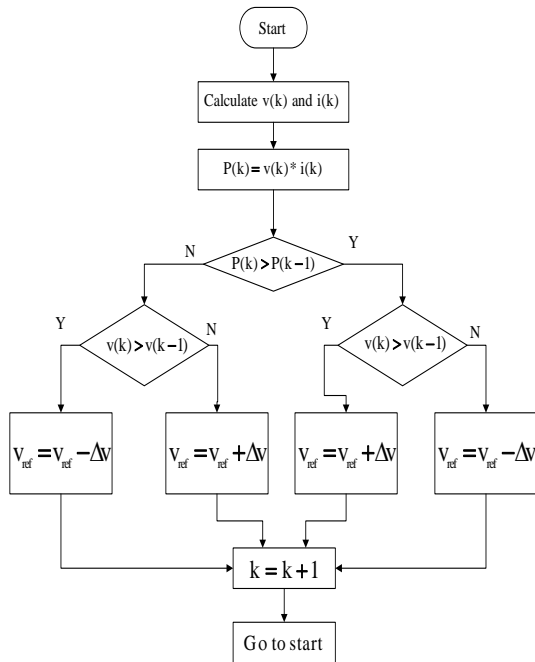

Fig 5. P & O observation technique

Fig. 5 shows the algorithm of the P&O MPPT method. As the name says, the algorithm is based on the observation of the array output power and on the perturbation of the power based on increments of the array voltage or current. The algorithm continuously increments or decrements the reference current or voltage based on the value of the previous power sample. The P&O method is claimed to have slow dynamic response and high steady state error. In fact, the dynamic response is low when a small increment value and a low sampling rate are employed. Low increments are necessary to decrease the steady state error because the P&O always makes the operating point oscillate near the MPP, but never at the MPP exactly. The lower the increment, the closer the system will be to the array MPP. The greater the increment, the faster the algorithm will work, but the steady state error will be increased. Considering that a low increment is necessary to achieve a satisfactory steady state error, the algorithm speed may be increased with a higher sampling rate. So there is always a compromise between the increment and the sampling rate in the P&O method.

### IV.PHASE LOCKED LOOP

Frequency is the time derivative of phase. Keeping the input & output phase in lock step implies keeping the input & output frequencies in lock step. Consequently, a phase locked loop can track an input frequency, or it can generate a frequency that is multiple of input frequency. The former property is used for demodulation, and latter property is used for indirect frequency synthesis. Phase-locked loop are widely employed in radio, telecommunications, computers and other electronics applications. They

can be used to recover signal from a noisy communication channel, generate stable frequencies at a multiple of an input frequency, or distribute clock timing pulses in digital logic designs such as microprocessors [4].

The PLL is used to provide a power factor operation which involves synchronization of the inverter output current with the grid voltage and to give a clean sinusoidal current reference. Whenever reference signal are in phase i.e, error signal are zero then we will sure that both PV source and load voltage are produced same voltage and they are synchronized each other

#### A. An all digital PLL in simulink

PLLs are used more and more in digital domain, this means that apart for the phase frequency detector, also the loop filter and VCO need to be converted to discrete-time system. The loop filter can be converted from Laplace to the z-domain using an appropriate transformation. The VCO(voltage controlled oscillator)need to be replaced by NCO( numerically controlled oscillator)

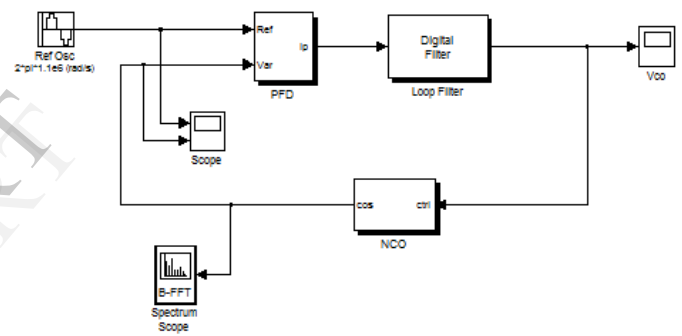

Fig 6. Simulink model of PLL

The digital filter has been implemented using a digital filter block from the signal processing block set's filter design library.

### V.PWM GENERATOR

Grid-connected single-phase inverters are normally full bridge voltage source inverters as shown in Fig.8 below

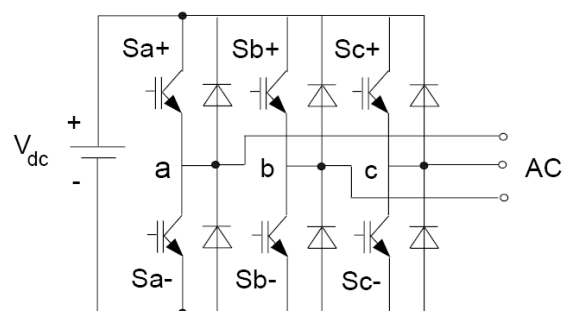

Fig 7. Grid connected IGBT inverter system

The single phase grid connected inverter can be broadly classified into two categories:

inverters with isolating transformer and inverters without it, where the former ones offer better EMI capability than transformer less inverters. Here first transformer is taken into consideration. The three-phase grid connected inverter shown in fig.7 is composed of a dc voltage source ( $V_{dc}$ ), six switches, and utility grid ( $V_{grid}$ ). In inverter-based DG, the produced voltage from inverter must be higher than the  $V_{grid}$ . It is required to assure power flow to grid. Since  $V_{grid}$  is uncontrollable, the only way of controlling the operation of the system is by controlling the current that is following into the grid [5][6].

VI. WORKING PRINCIPLE OF GRID CONNECTED PV SYSTEM

The output behavior of V & I waveform from PV cell to inverter shown in below fig 8.

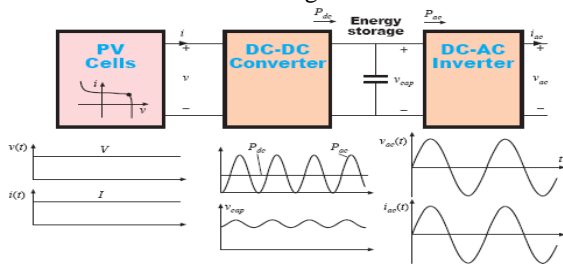

Fig 8. Behavior of V & I from PV cell to inverter

Electricity produced by PV array most efficiently during sunny periods. At night or during cloudy periods, independent power systems use storage batteries to supply electricity needs. With grid interactive system, the grid acts as the battery, supplying electricity when the PV cannot. During the day, the power produced by the PV array supplies load. An inverter convert direct current produced by the PV array to alternating current and transfer stepped up the voltage level as need for export to grid. Grid interactive PV systems can vary substantially in size. However all consists of solar arrays, inverter, electrical metering and components necessary for wiring and mounting.

A. Condition for grid interfacing

There are some conditions to be satisfied for interfacing or synchronizing the SPV system with grid or utility. If proper synchronizing is not done then SPV potential can't be fed to the grid[7]. The conditions for proper interfacing between two systems are discussed below:

- Phase sequence of SPV system with conventional grid should be matched . for this 3- $\Phi$  should be 120<sup>0</sup> phase apart from each other for both the system
- Frequency of SPV system should same as grid. Generally grid is of 50Hz frequency capacity

- One of the vital point is voltage matching . voltage level of both the system should be same, otherwise synchronizing not possible

B. System sizing and specification

TABLE II. SOLAR PV SPECIFICATION

No. of phase	3- $\Phi$
Voltage rating	400V
Frequency	50Hz
Current	40A

TABLE III. SPV POWER PLANT SPECIFICATION

plant capacity	1420 W
Voltage output	400 V
Current output	40 A
No of module	100

TABLE IV. SOLAR PANEL SPECIFICATION

Watt	131 W
Voltage	22 V
Current	7.2 A
Type	Polycrystalline
Efficiency	14.3 %
Dimension(mm)	1593*790*50
Temperatures	25 deg c
Mounting	Fixed

VII. SIMULATION RESULT

The overall block diagram and simulation result are discussion below

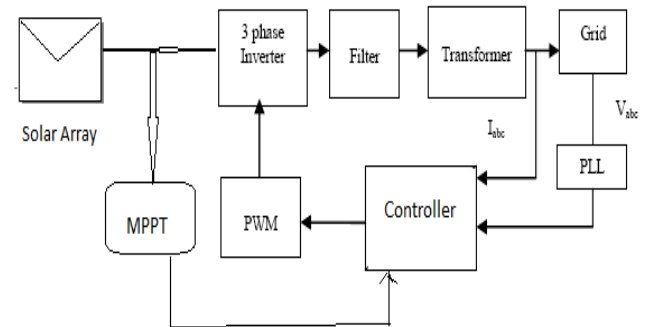

Fig 9. Over all block diagram of system

When the system is on steady state and solar radiation is 1000 w/m<sup>2</sup> and temperature is 25 deg c.

A. Simulink result of MPPT controller

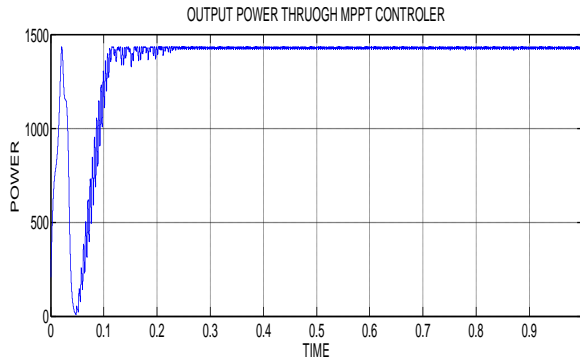

Fig 10. MPPT controller output of solar PV system

Here MPPT controller shows the output of 1420 watt using P & O observation technique

B. Simulink result of Phase Locked Loop

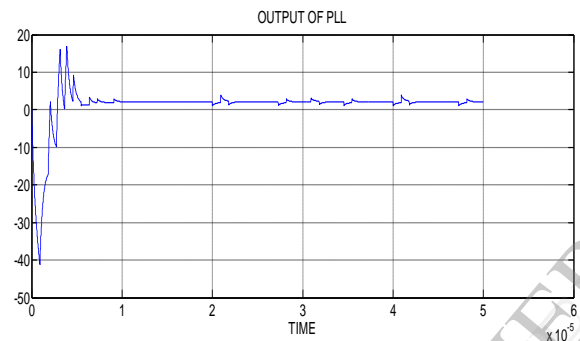

Fig 11. PLL shows both source are in phase

Here the error signal shows zero i.e, reference signal are in phase so they satisfied the condition of synchronization.

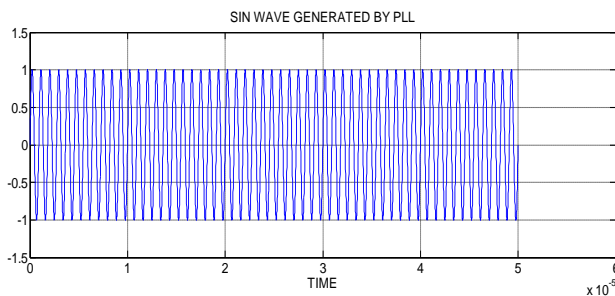

Fig 12. Sin wave generated by PLL

C. Simulink result of PWM generator

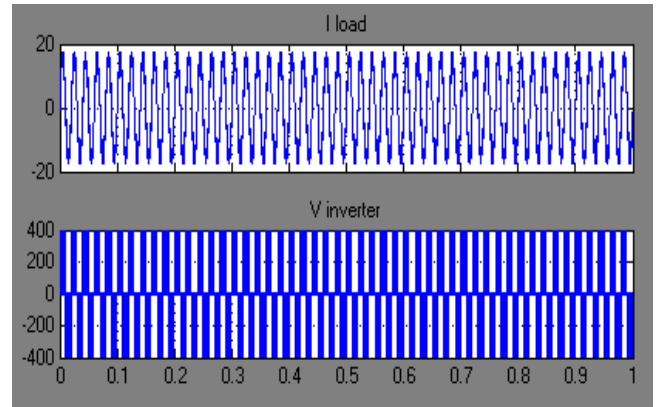

Fig 13. Load current and voltage from inverter

D. Simulink result grid connected PV system

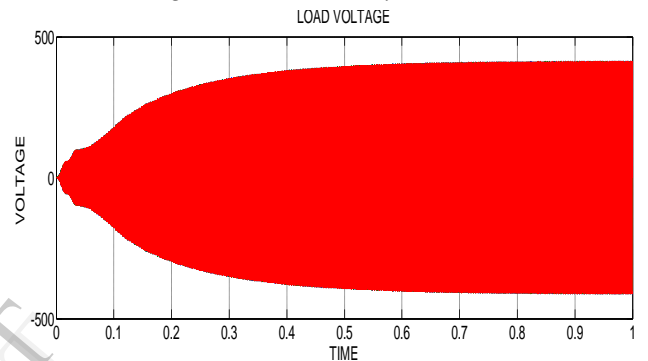

Fig 14. Load voltage wave form

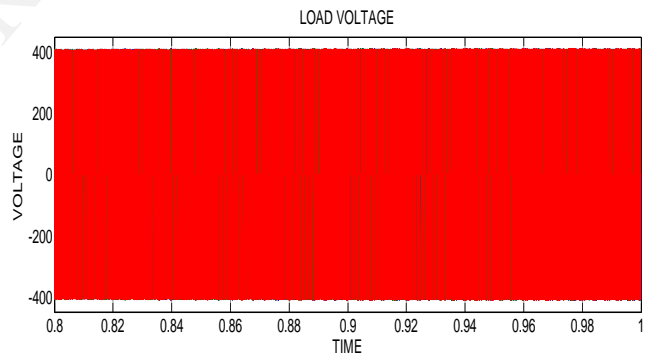

Fig 15. enlarging the load voltage wave form

From this voltage waveform we observe that load voltage produced 400V.

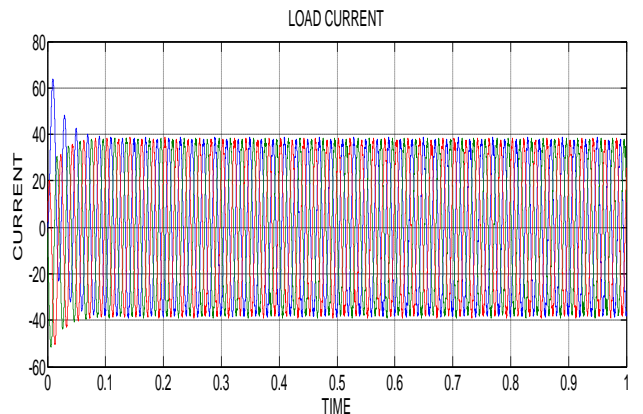

Fig 16. Load current wave form

Here load current is 40A current with RLC load connected to grid.

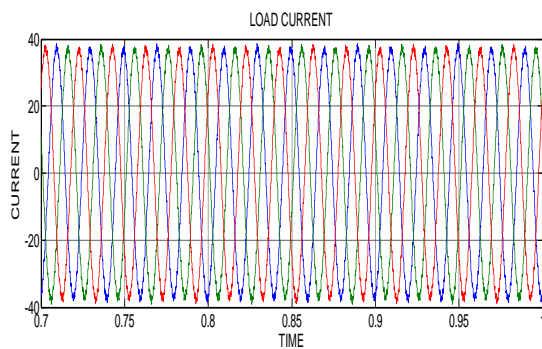

Fig 17. enlarging the load current waveform

#### E. Simulink result of PV system with MPPT controller

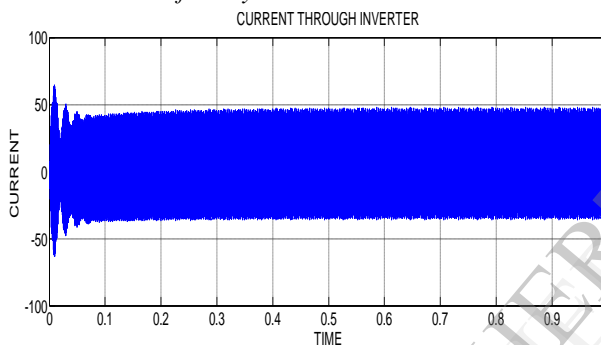

Fig 18. Current wave form of inverter

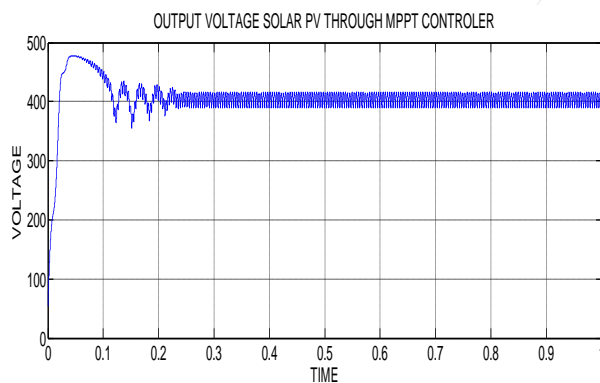

Fig 19 .output voltage of solar pv system

The output voltage of solar pv system is 400V. previously from fig. no 19 we get the output of load voltage is 400V. according to synchronization process both source should produced same voltage as they satisfied the condition here.

#### VIII.CONCLUSION

From the study we observe that in the PLL technique reference signal are in phase shown by fig. no 15, so that the error signal are zero, so here we get conclusion that the both source are in phase with each other i:e, both load voltage and solar PV produced same voltage of 400V. By using the MPPT controller we get the output power of solar PV system is 1420W. The proposed system models are implemented in Mat lab/Simulink environment and interfaced with Sim Power system toolbox. The dynamic behavior of each subsystem is investigated showing the interaction between different components of grid connected PV system. The system gives a very good behavior for grid connected PV system mode and stand alone mode. The electrical loads of the clinic completely supplied with electrical energy. The maximum power point is achieved.

#### IX.REFERENCE

- [1] honghai kuang,shengqing li,zhengqiu Wu,"Discussion on advantages & disadvantages of DG connected to grid."IEEE,pp.170-173,2011
- [2] R. Messenger and J. Ventre, Photovoltaic Systems Engineering, CRC Press, 2000, pp.41-51
- [3] Satyaranjan Jena Member, IEEE, and B.Chitti Babu, Member IEEE, Amiya Kumar Naik, Gokulananda Mishra. Performance Improvement of Single-Phase Grid-Connected PWM Inverter Using PI with Hysteresis Current Controller 978-1 4673-0136-7/11/\$26.00 ©2011 IEEE
- [4] Roland E. Best, Phase-locked loops: Theory, Design and Application, McGraw-Hill, New York, 2nd edition, 1993, pp. 93 . 104
- [5] Rahman, M.A.; Radwan, T.S.; Osheiba, A.M.; Lashine, A.E.; "Analysis of Current Controllers for Voltage-Source Inverter" *IEEE Trans. On Industrial Electronics*, Volume: 44 , no. 4 , Pp. 477 – 485, ,1997
- [6] Heinz Willi van der Broeck and Hans-Christoph Skudelny, Analysis and Realization of a Pulse With Modulator Based on Voltage Space Vectors, in *IEEE Transactions on Industry Applications*, 1988, pp. 142 . 150
- [7] N. Goshima, T. Kaito, M. Kawasaki, H. Koizumi, K. Kurokawa. T. Mizuno, K. Nagasaka and Y. Noda, A Novel Microcontroller for Grid-Connected Photovoltaic Systems, in *IEEE Transactions on Industrial Electronics*, 2006, pp.1889 . 1897