

# Octa-Cell HSPA+ Enabled UMTS Radio Access Network Planning: (Case in Addis Ababa)

<sup>1</sup>Solomon Gebru Abay, <sup>2</sup>Towfik Jemal Ali (Asst. Prof.)  
School of Electrical and Computer Engineering  
Jimma University  
Jimma, Ethiopia, January 2016

**Abstract**—This paper is based on the newly advanced cellular technology called Advanced-High Speed Packet Access plus (HSPA+) or just simply HSPA+. It gives a good understanding of the possibility of using multiple carriers while planning radio access network of Universal Mobile Telecommunications System (UMTS)/HSPA+ using eight carriers while transmitting in the downlink, and perform a case study in Addis Ababa City with a selected area. The UMTS/HSPA+ radio access network planning involves coverage estimation and capacity evaluation. The coverage estimation is done with consideration of the real environment information at its nominal stage to obtain better estimations. The propagation modeling is done using Cost-Hata model with the inclusion of taking in to consideration the effect of using multiple carriers. The maximum of the site counts, by considering the multi-carrier effect, based on coverage and capacity analysis is taken as a final number of required sites. The simulation was performed using Atoll 3.2 Radio Planning and Optimization Software to evaluate both the coverage prediction and Monte-Carlo simulation, which is needed for capacity estimation for each service. This simulation software is also used for comparing the effect of octa-cell based system with the system which operates on fewer carriers.

**Index Terms**—Addis Ababa; Atoll; Cost-Hata; HSPA+; Monte-Carlo; Octa-cell; Optimization; UMTS

## I. INTRODUCTION

There is a continuous thrust to improve data rates in both uplink and downlink in mobile telecom networks. Currently, most part of the country is offering a 3<sup>rd</sup> Generation (3G) UMTS/HSPA service with a maximum data rate of 42Mbps in downlink (DL) and 11Mbps in uplink (UL) using a 5 MHz single carrier frequency. So, it will not be complex to bring the concept of carrier aggregation of multiple carriers from certain frequency bands into the existing 3G UMTS/HSPA radio network.

The idea of multi-carrier usage has been driven by operators' increasing technology and operational challenges in terms of data capacity. The initial UMTS deployments focused mainly on coverage maximization, and thus, a single carrier capacity was adequate to cope with the subscriber requirements [1][2][3].

Recently, rapid data user growth took place due to several factors on top of HSPA availability; better user experience for broadband multimedia applications, high speed Internet and availability of relatively cheap Smartphone handsets. Therefore, operators acquired several spectrum licenses and deployed HSPA networks with multiple carriers to meet the

capacity requirements. This research encompasses the concept of 8C-HSPA+ based radio network planning for UMTS networks by taking in to consideration the specifications mentioned in 3GPP Release 11 and addresses the various issues concerning capacity, coverage, quality of service, interference and interoperation with previous radio networks. The features being introduced to Release-11 include 8-Carrier High Speed Downlink Packet Access (HSDPA), Downlink Multi-flow Transmission, Downlink 4-branch multi input multi output (MIMO), Uplink dual antenna beam-forming and MIMO together with 64QAM and a number of small enhancements to the Cell Forward Access Channel (Cell\_FACH) state.

In the downlink, 8C-HSDPA extends the HSDPA carrier aggregation up to 40MHz aggregate bandwidth by enabling transmission simultaneously on up to eight carriers towards a single UE. The carriers do not necessarily need to reside adjacent to each other on a contiguous frequency block, as it is possible to aggregate carriers together from more than one frequency band [4][5][6]. Accordingly, this paper works on aggregating eight carriers from Band-I (2100 MHz). This also includes a partial overview of aggregating carriers from two frequency bands, Band-I and Band-VIII (900 MHz).

As of [6], the first carrier aggregation was started using two sequential 5MHz carriers. And there is also a possibility that using multiple carriers, above two, the data rate and user throughput can be enhanced. In the developed countries like in Europe, the network operators would love to deploy a network with multiple carriers. But there is a huge limitation of carrier spectrum since there are multiple network operators. Likewise in our country, Ethiopia, there are additional frequency spectrums which are available if our only network operator, Ethio-telecom, has the willingness to use these carriers for optimization of the data rate, capacity and user throughput of its services. Moreover, the cost is not a big issue since it can be implemented with low cost.

### A. Related works and the Contribution of this work

There are few researches specifically focused on W-CDMA networks, which supports multiple carriers on downlink [6]-[9]. In [6], the continuous improvements of WCDMA/HSPA with Dual-Carrier HSDPA in terms of spectral efficiency, latency, and multi-carrier operation (or carrier aggregation) for individual connections was addressed. And the achievable system performance (with focus on downlink) was evaluated; however, if the network operator has an access to more

carriers, we can get more improvements than the mentioned ones. In [7], radio network planning on 2G, 3G and 4G was reviewed by classifying the planning process into dimensioning, planning, and optimization; however, it does not consider the effect of having multiple carriers in the system. In [8], advantage of deploying UMTS with HSPA technology was studied, including the profits for the network operator and for the subscribers of this service. In [9], the factors that should be taken into consideration while working with capacity dimensioning of multi-carrier HSPA system was studied, even though the study does not mention the effect of the environment type.

### B. Assumptions and Notations

The bold italic subscript  $d_B$  and  $d_{Bm}$  are notations used for identifying the measurement type. While calculating the coverage and capacity parameters, some default values are considered, and these default values and assumptions are taken from the 3GPP Release-11 specification document.

The remaining of this paper is organized as follows. In Section II provides research methodology models, including the general and specific planning processes. In Section III, the UMTS/HSPA+ Radio Access Network (RAN) planning is discussed, including the possible input and output parameters. In Section IV, the detail evaluation of radio link budgeting (RLB), the coverage prediction and capacity analysis is discussed under Results and Discussions. The simulation for coverage prediction and Monte-Carlo simulation is also discussed on this section. Finally, conclusions are drawn under Section V.

## II. RESEARCH METHODOLOGY

The selection of WCDMA as the air interface technology for the 3G mobile communication networks leads to a considerable paradigm shift in radio network planning. The requirements that the radio network planning has to fulfill are best illustrated using the coverage, capacity, and quality of service (CCQ) [14].

### A. Network Planning Process

Coverage and Capacity planning is dependent on the selected scenario, i.e. the results depend on the specific scenario parameters such as site selection, antenna-specific parameters, propagation, traffic and mobility models used for the environment simulation. Therefore, a careful selection of the environment parameters that will characterize the specific scenario should be the primary step while network planning. The propagation model and the traffic models are the other factors that greatly affect radio access network planning. Therefore, they need to be carefully defined for each scenario so as to closely represent the reality.

The methodology for planning a WCDMA radio network consists of three main phases, as seen in the figure below [1][3]; the initial planning (dimensioning) phase, the detailed planning phase, and the post-planning (optimization) phase. The initial planning phase aims at providing a first estimate on the number of required sites and the basic configuration of the NodeBs. In order to achieve this task, it is necessary to identify the services operated by the network and the service specific requirements: What is the target coverage probability, what is the target blocking probability, what is the desired

QoS? As the UMTS provides different services, these planning parameters have to be defined for every service and the service with the tightest requirements constitutes the planning target. While the initial phase gives only a rough estimate on the required site density, the aim of the detailed planning phase is to select and configure NodeB sites. Furthermore, the detailed planning phase comprises the parameter planning where the NodeBs obtain their downlink scrambling codes, and parameters regarding radio resource management, handover strategies, etc. are set.

On the first phase, UMTS/HSPA+ radio access network planning starts with the RLB calculation which is used to determine the maximum path loss. The result of this step depends on the selected propagation model. The estimated cell size obtained in this step leads to the maximum allowed size of the cells. This parameter is used to calculate the number of cells in the area of interest. Thus, a rough estimate of the required number of NodeBs is obtained.

On the next phase, capacity calculations follow the above process for coverage estimation. If the coverage estimates for the given configuration, fulfils the capacity requirements, then no need of addition to the previous plan. On the other hand, suitable number of cell sites is added to achieve the capacity targets. If the highest expected traffic is used, then it can lead to an unnecessary high number of sites. The following figure depicts UMTS/HSPA+ planning process in detail.

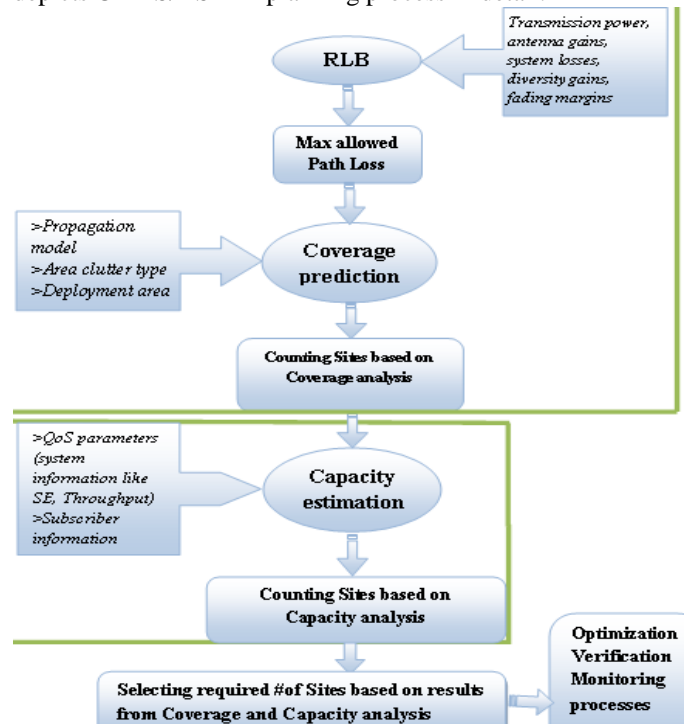

Fig. 1. Detail RAN planning process of this thesis

The post-planning or optimization phase includes the verification, monitoring, and optimization processes. It starts when the network is implemented, and measurements in the real network can be made. In a first step before the network enters the operational phase, the predicted coverage area is verified by radio interface field measurements. Then, key performance indicators are identified and continuously

monitored during the operational phase. Thus, coverage, capacity, or QoS problems are detected and resolved by changing the network layout or the site configurations. The detailed planning phase is entered again to validate these changes before they are actually applied to the network. This thesis mainly focuses on the first two steps since optimization is not the specific objective of the research.

### III. UMTS/HSPA+ RAN PLANNING

The proper planning of the HSPA+ is a very important activity that will determine to a large extent the coverage, capacity, and quality of the service. No matter how much effort is invested in maintaining a network, if the original planning is flawed it will be a constant headache for the engineering teams [14]. The main focus area while deploying HSPA+ are the radio nodes, including NodeB site location and antenna and power configuration.

#### A. Radio Access Network Overview

Figure 4.1 illustrates the general architecture of UTRAN, which basically consists of one or more RNS. In the UTRAN, the RNS controls the allocation and release of radio resources while establishing a communication path between the UE and UTRAN. Usually the RNS consists of a RNC and one or many NodeBs, where the number of NodeBs depends on the result found from calculation of number of capacity or coverage based site counts. Both the RNC and NodeB are connected through the Iub interface in the RNS. In the presence of many RNCs in the UTRAN, the Iur interface is used to connect all of these RNCs [1][2][3][14].

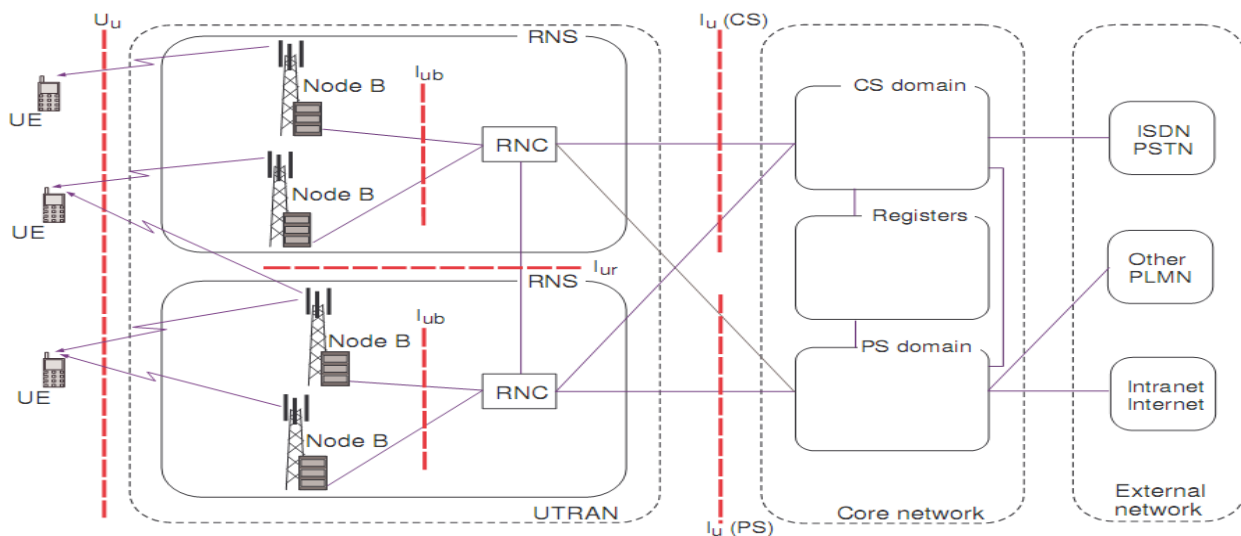

Fig. 2. UTRAN Architecture

Coverage estimation is used to determine the coverage area of each NodeBs. Coverage estimation calculates the area where NodeBs can be heard by the users. It gives the maximum area that can be covered by the NodeB. But, it is not necessary that an acceptable connection (e.g. a voice call) between the transmitter and receiver can be established in coverage area. However, NodeB can be detected by the user

As a whole, planning is an iterative process covering design, synthesis and realization. The aim of this sub-section is to provide a method to design the wireless cellular network such that it fits the needs of any wireless cellular network.

Planning of a wireless cellular network is based on a set of certain parameters, and the provided results are relevant for that set of parameters only [25]. The planning tool, Atoll on this case, should be accurate enough to provide results with an acceptable level of accuracy, when loaded with expected traffic profile and subscriber base.

Wireless cellular network planning is directly related to the quality and effectiveness of the network, and these will have large impact on network development. Wireless cellular network planning generally follows the following basic steps:

- Data/Traffic Analysis
- Coverage Estimation
- Capacity Evaluation
- Transport Dimensioning

Traffic analysis gives an estimate of the traffic to be carried by the system. Different types of traffic that will be carried by the network are modeled. Traffic types may include voice calls, VOIP, PS or CS traffic. Time and amount of traffic is also forecasted to evaluate the performance of the network using the Monte-Carlo result and to determine whether the network can fulfill the requirements set forth.

in coverage area. Coverage planning includes RLB and coverage analysis. RLB computes the power received by the user given a specific transmitted power for NodeB. RLB comprises of all the gains and losses in the path of signal from NodeB to the User. This includes transmitter and receiver gains as well as losses and the effect of the wireless medium between them.



Based on the calculation of RLB, maximum allowed propagation loss is obtained. Maximum allowed propagation loss gives the attenuation of the signal as it travels from transmitter to the receiver. Path loss is converted into distance by using appropriate propagation models. On this thesis, Cost-Hata propagation model has been selected as appropriate model for whole area of Addis Ababa since this propagation model is recommended for the selected frequency band. This is the distance from the NodeB where the transmitter signal can be received by the users. This distance or radius of the cell is used to calculate the number of sites required to cover the whole area with respect to coverage estimation.

Capacity planning deals with the ability of the network to provide services to the users with a desired level of quality. After the site coverage area is calculated using coverage estimation, capacity related issues are analyzed like site selection. In WCDMA-based wireless cellular systems, coverage and capacity are interrelated. Hence, data pertaining to user distribution and forecast of subscriber's growth is of utmost important. Capacity evaluation gives an estimate of the number of sites required to carry the predefined traffic over the coverage area [27].

Once the number of sites according to the traffic forecast is determined, the interfaces of the network are dimensioned, which is not the scope of this thesis. Number of interfaces can vary from a few in some systems to many in others.

### B. UMTS/HSPA+ Radio Access Network Planning

The target of the UMTS/HSPA+ radio access network planning is to estimate the required site density and site configurations for the area of interest. Initial UMTS/HSPA+ radio access network planning activities include RLB and coverage analysis, cell capacity estimation, estimation of the amount of NodeB and hardware configuration, and finally equipment at different interfaces. This section focuses on the issues related to UMTS/HSPA+ network planning.

While planning a UMTS/HSPA+ network, there are lots of parameters which are treated as inputs and outputs of the deployment process. And these parameters are categorized as quality, coverage, and capacity-related parameters.

#### 1) Input Parameters

Quality-related inputs include average cell throughput and blocking probability. These parameters are the customer requirements to provide a certain level of service to its users. These inputs directly translate into quality of service (QoS) parameters. Besides, cell edge performance criterion is used in the dimensioning tool to determine the cell edge. These include user defined maximum throughput at the cell edge, maximum coverage with respect to lowest MCS (giving the minimum site count) and predefined cell radius. With a predefined cell radius, parameters can be varied to check the data rate achieved at this cell size. This option gives the flexibility to optimize the transmitted power and determining a suitable data rate corresponding to this power.

Coverage-related inputs include RLB inputs and propagation model. RLB is of the central importance to coverage planning in UMTS/HSPA+. RLB inputs include maximum transmitter power, transmitter and receiver antenna systems, number of antennas used, conventional system gains

and losses, cell loading and propagation models. Advanced-HSPA+ can operate in both the conventional frequency bands of 900 MHz and 2100 MHz effectively with high efficiency. Analysis of operating in 2100 MHz frequency band is incorporated in this thesis. Additionally, channel types (Pedestrian, Vehicular) and geographical information is needed to start the coverage planning phase. Geographical input information consists of area type information, (Urban, Rural, etc) and size of each area type to be covered. Furthermore, required coverage probability plays a vital role in determination of cell radius. Even a minor change in coverage probability causes a large variation in cell radius.

Capacity-related inputs include traffic forecast for each type of traffic, utilization factor and subscriber geographical spread. Subscriber geographical spread gives the percentage of population to be covered by the network in the deployment area. There are three types of deployment areas considered; city/urban, suburban and rural. And these inputs are vendor specific. Capacity planning inputs provides the requirements, to be met by the UMTS/HSPA+ RAN planning. Capacity planning inputs gives the number of subscribers in the system, their demanded services and subscriber usage level. Available spectrum and channel bandwidths used by the UMTS/HSPA+ system are also very important for capacity planning. Traffic analysis and data rate to support available services, on this case data, are used to determine the number of subscribers supported by a single cell and eventually the cell radius based on capacity evaluation.

Generally, proper set of input parameters is vital for radio access planning to yield accurate results. Wireless cellular network planning requires some fundamental data elements. These parameters include subscriber population, traffic distribution, geographical area to be covered, frequency band, allocated bandwidth, and coverage and capacity requirements. Propagation models according to the area and frequency band should be selected and modified, if needed. This is necessary for coverage estimation. System specific parameters like transmit power of the antennas, their gains, estimate of system losses, type of antenna system used etc, must be known prior to the start of wireless cellular network planning.

I/p Parameters	For DL	For UL
Frequency Band	2100 MHz	
Bandwidth	40 MHz	
No. of Carriers	Eight	
Duplex	FDD	
Propagation Model	Cost-Hata	
Digital map	Digital map of Addis Abeba	
Frequency reuse	1	
MIMO Configuration	2X2 MIMO	1X2 MIMO
Selected Cell shape	Hexagonal	

Table 1. Fundamental input parameters of RAN planning

#### 2) Output Parameters

The output of UMTS/HSPA+ planning process indicates the feasibility of the planned network. The first result that we will get is the cell size. It is the main output of the UMTS/HSPA+ network planning. Two values of allowed path loss are obtained, one from downlink High Speed-Downlink Shared Channel (HS-DSCH) evaluation and second from downlink HS-SSCH evaluation. The smaller of the two

numbers is taken as the final output. Cell radius is then used to determine the number of sites. Assuming a hexagonal cell shape, number of sites can be calculated by using simple geometry. Capacities of NodeBs are obtained from capacity evaluation, along with the number of subscribers supported by each cell. Interface dimensioning is the last step in UMTS/HSPA+ advanced planning, which is out of the scope of this thesis work.

#### IV. RESULTS AND DISCUSSION

This section discusses how the number of sites has been evaluated from coverage and capacity point of view. And the simulation results will also be mentioned here.

##### A. RLB and Coverage Prediction

Coverage planning is the first step in the process of radio access network planning. It gives an estimate of the resources needed to provide service in the deployment area with the given system parameters, without any capacity concern. Therefore, it gives an assessment of the resources needed to cover the area under consideration, so that the transmitters and receivers can listen to each other. In other words, there are no QoS concerns involved in this process. Coverage planning consists of evaluation of the DL and UL RLBs. The maximum path loss is calculated based on the required SINR level at the receiver, taking into account the extent of the interference caused by traffic. The minimum of the maximum path losses in the DL and UL directions is converted into cell radius, by using a propagation model appropriate to the deployment area, which is Cost-Hata in this case. RLB is the most prominent component of coverage planning exercise.

The detail for RLB is explained followed by the methods used for calculation of the required SINR, effect of interference and finally the calculation of the number of sites based on the coverage.

RLB calculations deal with the coverage estimation of UMTS/HSPA+ network. RLB is calculated in order to estimate the allowed path loss. Transmission powers, antenna gains, system losses, diversity gains, fading margins, etc are taken into consideration in a RLB. RLB gives the maximum allowed path loss, from which cell size is calculated using Cost-Hata propagation model.



Fig. 3. RLB through System range

For UMTS/HSPA+, the basic RLB equation can be written as follows:

$$APL_{dB} = TxEIRP_{dBm} - RxSensitivity_{dB} - I_{dB} + RxAntennaGain_{dBi} - RxBodyLoss_{dB} + DiversityGain_{dB} - FFMargin_{dB} + SHGain_{dB} - IndoorPenetrationLoss_{dB} - SFMargin_{dB} \quad (1)$$

Where, APL = Total allowed propagation loss encountered by the signal from transmitter to receiver

TxEIRP = Transmitter Effective Isotropic Radiated Power

- RxSensitivity = Receiver Sensitivity
- I = Interference Margin
- RxAntennaGain = Receiver Antenna Gain
- RxBodyLoss = Receiver Body Loss
- FFMargin = Fast Fading Margin
- SHGain = Soft Handover Gain
- SFMargin = Shadow Fading Margin

Effective isotropic radiated power is the amount of power that would have to be transmitted by an isotropic antenna (that evenly distributes power in all directions and is a theoretical construct) to produce the peak power density observed in the direction of maximum antenna gain. EIRP can take into account the losses in transmission line and connectors and includes the gain of the antenna [28].

$$TxEIRP_{dB} = (TxPower\ on\ HS-DSCH)_{dBm} + TxAntennaGain_{dBi} - TxCableLosses_{dB} \quad (2)$$

The Transmitter Power on HS-DSCH contains 80% of the total transmit power on NodeB, and HS-SCCH will have 5% of the total NodeB transmit power [29];

$$(TxPower\ on\ HS-DSCH)_{dBm} = 0.8 * TotalNodeBTxPower_{dBm} \quad (3)$$

An antenna is the converter between cable-bounded electromagnetic waves and free space waves. Most common antenna gain measure is dBi = dB(isotropic). It is the forward gain of a certain antenna compared to the ideal isotropic antenna which uniformly distributes energy to all directions. Another measure that is used is dBd = dB(dipole). The relation between dBi and dBd is:

$$dBi = dBd + 2.15dB \quad (4)$$

Considering an ideal standard directional panel antenna, its horizontal 3dB beam width is 65 degrees for 3-sector site. Another assumption considered on this research is that antennas in which there are 6 λ/2 dipoles on top of each other so that narrow vertical beam can be formed [29]. Based on this;

$$VerticalPattern_{dBd} = 10 * Log (no. Of dipoles) dBd \quad (5)$$

$$VerticalPattern_{dBi} = VerticalPattern_{dBd} + 2.15dB \quad (6)$$

$$HorizontalGain_{dB} = 10 * Log (360/65) \quad (7)$$

Therefore,

$$TxAntennaGain_{dBi} = VerticalPattern_{dBi} + HorizontalGain_{dB} \quad (8)$$

The other component of RLB, RxSensitivity, represents the weakest signal that can be received by the receiving antenna. This term is expressed as;

$$RxSensitivity_{dB} = RxNoisePower_{dBm} - SpreadingGain_{dB} + RequiredSINR_{dB} \quad (9)$$

Where,

$$RxNoisePower_{dBm} = RxNoiseDensity_{dB} + 10Log(ChipRate) \quad (10)$$

And

$$RxNoiseDensity_{dB} = ThermalNoiseDensity_{dBm/Hz} + RxNoiseFigure_{dB} \quad (11)$$

$$ThermalNoiseDensity_{dBm/Hz} = 10Log(B*290/0.001) \quad (12)$$

Where  $B$  is Boltzmann's constant, which equals  $1.38*10^{-23}$ . The receiver noise figure represents the loss of the signal power in the receiver part. It is most commonly in range of 5dB – 9dB. Precise value of this parameter is product specific. Before the release of HSPA, the spreading factor was considered as a variable value. But, in HSPA systems the spreading factor is fixed, and is equivalent to 16 in HS-DSCH and 128 in HS-SCCH. And the spreading gain is multiple of this fixed spreading factor. i.e.

$$Spreading Gain_{dB} = 10Log(SF) \quad (13)$$

Where, SF = Spreading Factor

The required SINR value is most commonly important parameter while evaluating RLB of a certain cellular system. It will determine the achievable bit rate for the HSPA+ service. In interference limited conditions, the required SINR for HSPA+ can be estimated as:

$$Required SINR = SF * TxPower_{on HS-DSCH} / (TotalNodeB TxPower * [1 - \alpha + 1/G]) \quad (14)$$

Where  $\alpha$  = DL orthogonality factor in certain location in the cell which is another important factor to consider in the HSDPA link budget calculation. This factor takes into account the impact of multipath propagation on the SINR. The orthogonality factor is between 0.5 and 1 for typical environments.

$G$  = Geometry factor. This factor indicates how susceptible that location is to receiving interference from external cells. It is defined as:

$$G = \frac{P_{own}}{P_{other} + P_{noise}} \quad (15)$$

Where,  $P_{own}$  is the power from the serving cell.

$P_{other}$  is the interference power from the rest of the cells.

$P_{noise}$  is the thermal noise power,  $N_0$ .

As of [14], typical values of the geometry factor for cell edge are around -3 to -4dB. The same equation can be used for the HS-SCCH. The defined required SINR value is expected to be greater than or equal to the SINR of the system. This value is defined as follows:

$$SINR \geq Required SINR$$

$$SINR = Ave.RxPower / (Interference + Rx Noise) \quad (16)$$

Where, Ave.RxPower = the average received power of NodeB

Rx Noise = receiver noise

Indoor penetration loss parameter simply depends on the expected building wall losses. The value of this parameter depends on the service area type [14]:

- For Dense Urban = 20dB (20, 25) dB
- For Urban = 17dB (15, 20) dB
- For Suburban = 13dB (10, 15) dB
- For Rural = 9dB (5, 10) dB

It is good to recommend for network operators that target load should not be higher than 75% (especially UL is hard to manage when load is high, interference explodes).

Since interference is a function of loading, the value can be obtained from equation (17).

$$InterferenceMargin_{dB} = -10Log(1 - CellLoad in %) \quad (17)$$

The following table shows the list of Interference Margin values as a function of Cell Load.

Cell Load (%)	Interference Margin (dB)
20	0.97
35	1.87
50	3.01
60	3.98
75	6.02
90	10

Table 2. Load versus Interference Margin

Fast fading margin, also called PC headroom, ensures that the UL PC is able to compensate deep fades at cell border. But, fast fading margin is not needed in HSPA+ system since link adaptation is applied. Therefore, there is no soft handover gain.

Shadow fading margin of cell edge approach is needed because the buildings and other obstacles between the UE and Node B are causing changes in the received signal level at the receiver. This parameter is taken into account in the HSPA+ link budget calculation to assure a minimum signal level with the wanted probability. According to measurements in live UMTS network, it has been noticed that the practical shadow fading margin and standard deviation values are nearly the same for HSPA, WCDMA and GSM systems.

$$ShadowFadingMargin_{dB} = ShadowFadingStdDeviation_{dB} * \text{argument of } (1 - p) \quad (18)$$

Where  $p$  = Coverage probability on cell edge

The argument value of  $(1 - P)$  is taken from the next figure.

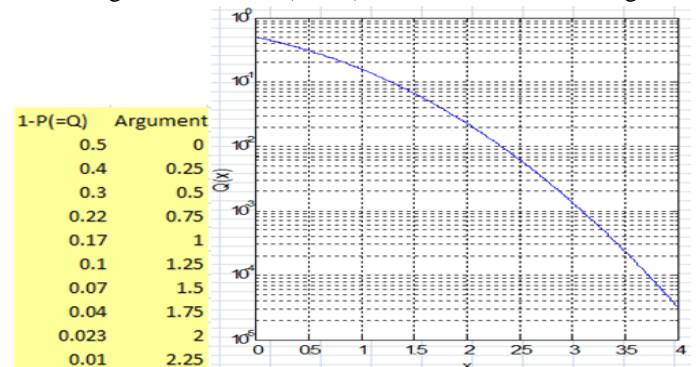

Fig. 4. For calculation of the argument value

As it is observed from Figure 4, the allowed propagation loss due to HS-DSCH is selected as the appropriate path loss of the system. The maximum actual propagation loss for Cost-Hata propagation model depends on the environment type and the operating frequency band. For all area types, this maximum path loss at 2100 MHz should not exceed 160 dB [39]. If it did, then the calculated cell range will not be true. Therefore, the calculated allowed propagation loss value can be taken as an appropriate loss of this system. By using the Cost-Hata propagation model, the cell range evaluation presented next to propagation model.

Cost-Hata model is used on this thesis to compute the path loss for the cell radius. This model is actually used for carrier frequencies between 1500 and 2000 MHz. the same model can be used for 2100 MHz carrier frequency, since this thesis assumed that the loss due to the higher frequency is compensated by the increase in the antenna gain; if there is a doubt loss due to the 100 MHz. For 2100 MHz carrier frequency, the Standard propagation model can be used instead. But, this propagation model doesn't consider the environment type. The expression is for all types of environments. There are other propagation models like Okumura-Hata model, but most of them do not fit this carrier frequency.

Propagation Model folder in the Modules tab of the browser window in the Atoll simulation software assign a different formula for each type of clutter map area. The allocation formula is as follows in Table 3:

No:	Zone Type	Surface (km <sup>2</sup> )	Area in percent(%)	Cost-Hata formula
1.	OPEN	301.25734	72.7	Urban
2.	INLAND_WATER	0.66	0.2	Rural (quasi-open)
3.	MEAN_INDIVIDUAL	43.59	10.5	Suburban
4.	MEAN_COLLECTIVE	1.8	0.4	Urban
5.	DENSE_COLLECTIVE	0.08	-	Dense Urban
6.	BUILDINGS	0.11	-	Dense Urban
7.	VILLAGE	0.23	0.1	Suburban
8.	INDUSTRIAL	10.24	2.5	Dense Urban
9.	OPEN_IN_URBAN	1.1	0.3	Suburban
10.	FOREST	38.52	9.3	Rural (quasi-open)
11.	PARKS	0.27	0.1	Rural (quasi-open)
12.	DENSE_INDIVIDUAL	10.32	2.5	Urban
13.	SCATTERED_URBAN	1.332	0.3	Suburban
14.	AIRPORT	4.961	1.2	Suburban

Table 3. Allocation of Cost-Hata formulas to different types of environment

The terms set out in the Atoll database for this method are as follows [33]:

$$a(Hm) = (1.1 \text{Log}f - 0.7)Hm - 1.56 \text{Log}f + 0.8 \quad (19)$$

$$PLE = 44.9 - 6.55 \text{Log}Hb \quad (20)$$

$$PLC = 46.3 + 33.9 \text{Log}f - 13.82 \text{Log}Hb - a(Hm) + C_f \quad (21)$$

$$a(Hm)_R = a(Hm) + 4.78 \text{Log}^2 f - 18.32 \text{Log}f + 35.94 \quad (22)$$

$$PLC_R = 46.3 + 33.9 \text{Log}f - 13.82 \text{Log}Hb - a(Hm)_R + C_f \quad (23)$$

For Dense Urban, Urban and Suburban City:

$$D = 10^{(APL - \text{Indoor Loss} - PLC)/PLE} \quad (24)$$

For Rural (Quasi-open) area:

$$D = 10^{(APL - \text{Indoor Loss} - PLC_R)/PLE} \quad (25)$$

Where, PLE = Path Loss Exponent

D = Cell range

PLC = Path Loss Constant

PLC<sub>R</sub> = Path Loss Constant for Rural area

Hm = effective height of MS

Hb = effective height of NodeB

a(Hm) = MS antenna gain function (MS antenna correction factor)

a(Hm)<sub>R</sub> = MS antenna gain function (MS antenna correction factor) for Rural area

C<sub>f</sub> = Clutter loss Correction

APL = Allowed Propagation Loss

The clutter loss correction factor, C<sub>f</sub>, values depends on the area type. These values in Cost-Hata model are defined as follows:

For Dense Urban:

$$C_f = 3 \text{dB}$$

For Urban:

$$C_f = 0 \text{dB}$$

For Suburban:

$$C_f = -2 * \text{Log}^2 ((f/28) - 8) - 5.4 \text{dB}$$

For Rural (quasi-open):

$$C_f = 0 \text{dB}$$

The following Figure 5 shows a snapshot of the calculated maximum allowed propagation loss for both channels, and the corresponding cell range using the Cost-Hata propagation model for the case multi-carrier implementation.

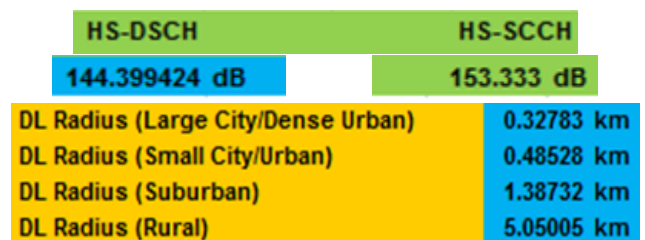

Fig. 5. The allowed propagation loss and the corresponding cell range

### B. Site Counting based on Coverage

The maximum allowed path loss can be used to calculate the cell radius by using appropriate propagation model for different area types. Given the cell radius, the cell coverage area depends on the site configuration. The following figure shows the different types of site configurations, and this thesis will continue using the tri-sector site configuration.



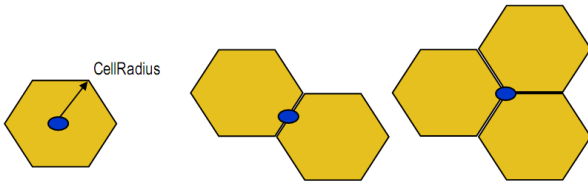

Fig. 6. Site configurations: (A). Omni-directional (B). Bi-sector (C). Tri-sector

For three hexagonal cell models, site areas can be calculated as follows:

$Site\ Area = K * Cell\ Radius^2$ , where value of  $K$  varies as of the configuration type.

Site configuration	Omni	2-sectored	3-sectored	6-sectored
Value of $K$	2.6	1.3	1.95	2.6

Table 4. Value of  $K$  for different site configurations

Omni-directional  $Site\ Area = 2.598 * Cell\ Radius^2$   
 (26)

$Cell\ Area = Site\ Area$   
 $Inter-site\ Distance = Cell\ Radius * \sqrt{3}$   
 Bi-sector  $Site\ Area = 1.3 * Cell\ Radius^2$   
 (27)

Tri-sector  $Site\ Area = 1.9485 * Cell\ Radius^2$   
 (28)

$Cell\ Area = Site\ Area / 3$   
 $Inter-site\ Distance = (3/2) * Cell\ Radius$

The number of sites needed to meet coverage requirements can be calculated by dividing the  $Site\ Area$  into the area to be covered, i.e.

$Number\ of\ Sites = Deployment\ Area / Site\ Area$   
 (29)

Where, deployment area is of the different service areas. The most part of the chosen area, Addis Ababa city, is urban. The total area of the selected part of the city is 414.47 square kilometers, where the maximum percentage of the total predicted subscribers' lives.

Based on this information, the following table summarizes the planning regions with their site area and the corresponding site number based on coverage planning.

Measures	Dense Urban	Urban	Suburban	Rural (Quasi)
Cell radius (km)	0.3278	0.4853	1.3873	5.05
No of cells per site	3			
Inter-site distance (km)	0.4917	0.7279	2.081	7.575
Site area (km <sup>2</sup> )	0.2094	0.4589	3.75	49.6916
Cell area (km <sup>2</sup> )	0.0698	0.153	1.25	16.564
Deployment area (km <sup>2</sup> )	10.32 (2.5%)	313.376 (75.6%)	51.301 (12.4%)	39.45 (9.5%)
# of sites	49	683	14	1

Table 5. Number of sites based on the coverage estimation

The above table tells us that if the operator prefers to deploy a UMTS/HSPA+ system from the coverage point of view, it requires deploying a total of 747 base stations all over the selected area. This number depends on classification of the whole clutter class as dense urban, urban, suburban and

rural area types. But, there is a gap while calculating the number of sites which is since the clutter type is located in different areas, so there might be an error on exact number of the NodeBs. So, this will be corrected and compensated in the optimization phase of the network planning process. For example for this case, the quasi open areas exist in different locations. If they were around the same place, it needs only one NodeB to satisfy the QoS. This means even though they are not around a same location, subscribers who are around these places can get a service using the NodeBs of the other areas.

### C. Capacity Planning

A multi-antenna solution with 2x2 MIMO has already been deployed in the downlink in commercial HSDPA networks. The next step is to push the multi-antenna transmission to 4x4 MIMO, which can double the peak data rate and also improve the typical cell capacity and user data rates. This can be seen in Figure 7, showing the average cell throughput. It can be seen that adding Rx antennas gives more benefits than adding Tx antennas, while the maximum gain is achieved by using four transmit and four receive antennas. In that case the system will automatically adapt the number of streams from a 4-transmit antenna with beam-forming, to up to four parallel MIMO streams.

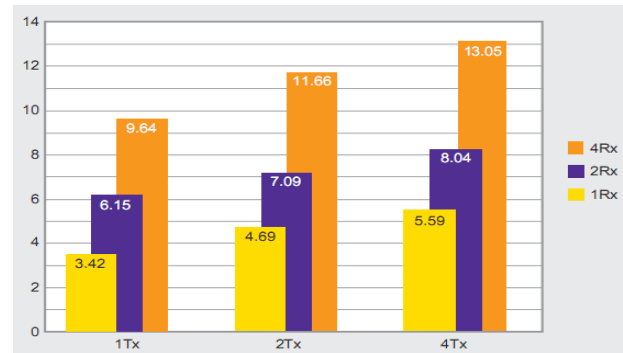

Fig. 7. Average cell throughput (Mbps) with Rx and Tx antennas [31]

Introducing 64QAM modulation does not require two transmit antennas, but when aiming for the highest peak data rates, it needs to be coupled with uplink MIMO. From the perspective of the ITU IMT-Advanced requirements, uplink beam-forming helps achieve the average and cell edge performance requirements. The uplink 2x2 MIMO together with 64QAM modulation, achieves 6.9 bits/s/Hz peak spectral efficiency, exceeding the IMT-A minimum requirement of 6.75 bits/s/Hz [31].

The purpose of this section is to describe the capacity planning for the UMTS/HSPA+ network, and to explain the methods used and factors impacting the capacity planning process. And the final outcome of this section will be number of NodeBs which are required to satisfy the QoS. The number of NodeBs can be calculated through two ways [38]; traffic volume-based site counting and data rate-based site counting.

#### 1) Data rate-based site counting

Since the given bandwidth can only deliver a certain amount of capacity, then the traffic demand needs to be understood. The complex part is the analysis of the peak hours of different subscriber types and traffic profiles. The required result is the overbooking factor that describes the



level of multiplexing or number of users sharing a given channel or capacity. The main inputs are listed below:

- Traffic mix and busy hour analysis
- Subscriber density
- Data volume per user
- Peak and average data rate
- Daily traffic profiles

For this method, let's consider 2 Mbps as a minimum DL user data rate of the whole 336 Mbps peak data rate. The busy hour in data networks is typically in the night, but data traffic is also generated during the evening. Hence since the traffic is not equally distributed the whole 24 hours period, 10% of the network's daily traffic is considered as a busy hour share. Another assumption to mention cell loading during busy hour, which ranges between 35 to 45%, is used to calculate the average busy hour cell throughput for the 40 MHz bandwidth cell capacity [38]. Therefore,

$$\text{Average BH data rate per Sub} = (\text{BH Offered data rate}) / \text{BH Share load} \quad (30)$$

$$\# \text{ of Sub per Site} = (\# \text{ of sectors}) * \text{ave. cell throughput} * \text{BH ave. loading} / \text{Average BH data rate per Sub} \quad (31)$$

The total number of sites to satisfy the traffic demand requirement for each subscriber is calculated using the following equation:

$$\text{Total \# of Sites} = (\# \text{ of Subscribers}) / (\# \text{ of Sub per Site}) \quad (32)$$

### 2) Traffic volume-based site counting

As coverage planning, also capacity planning is done separately for different service areas (Urban, Suburban, Rural, etc). If we use requirements corresponding to the peak hour traffic, then it would lead to over dimensioning. Precious resources will be wasted in other hours of the day and network cost will go significantly higher. For this reason, it is important to define the OBF. OBF is the average number of users that can share a given unit of channel. The channel unit used in planning is the peak data rate. If we assume a 100% channel loading, then the OBF is simply equal to the ratio between the peak and average rates. However, it is not safe to dimension the network with 100% call loading. Hence, the parameter utilization factor is introduced. In most of data networks, the utilization factor is less than 85% in order to guarantee QoS. So, the higher this parameter, the longer will be the average waiting time for users accessing the channel. Thus, the OBF is derived as follows:

$$\text{OBF} = \text{PeakToAverageRatio} * \text{UtilizationFactor} \quad (33)$$

With the knowledge of traffic demand estimation and the factors involved in it, overall data rate required can be calculated. Based on the OBF described above, the total data rate for the capacity calculation is:

$$\text{Overall Data Rate} = \text{Number Of Users} * \text{Peak Data Rate} * \text{OBF} \quad (34)$$

The number of sites necessary to support the above calculated total traffic is simply:

$$\text{Number of Sites} = \text{Overall Data Rate} / \text{Site Capacity} \quad (35)$$

Where, the Site Capacity is a multiple of the cell throughput, which depends on the number of cells per site (not considering any hardware limitation).

As already done for the coverage evaluation, the site count is performed for each type of service area. Capacity based site count is usually higher than the coverage based counterpart in a fully functional network. In real networks, this number is smaller in the early years of network operation, when the number of users is quite less. But as the demand increases and more users are added to the service, the capacity based site count takes the lead and smaller cells are required. The larger of the two counts is used as a final number as a dimensioning output.

Measures	Dense Urban	Urban	Suburban	Quasi
BH Ave. Loading (%)	45	40	40	35
BH Offered data rate (GB/Month)	35	50	35	35
Min. target data rate per subscriber (Mbps)	2			
System SE (bits/s/Hz)*	6.9			
BH Share load (%)	10			
Ave. Cell Throughput (Mbps)*	7.09			
Total # of Subscribers	2,232,900	12,350,000	220,525	115,776
# of Subscribers per site	49,620	30,873	44,105	38,592
# of sites	45	400	5	3
Final # of Sites	49	683	14	3

Table 6. Summary of site counting

\*These values are taken from [31]

### D. Coverage Prediction and Monte-Carlo Simulation

While working with the Atoll simulation, the digital map and the clutter information are the primary inputs. Figure 8 depicts the coverage prediction by the calculated transmitters in the downlink for the selected area.

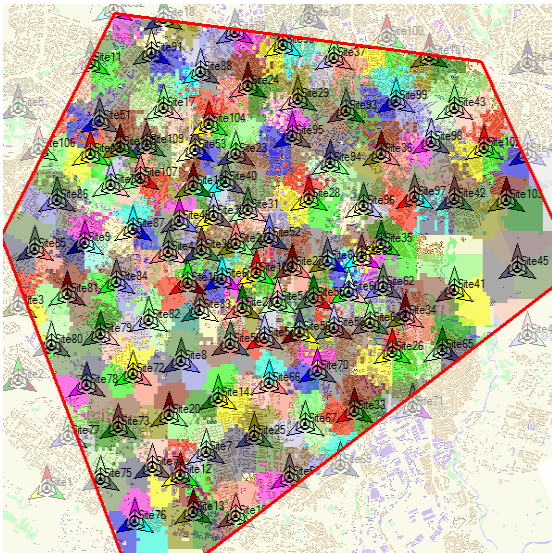

Fig. 8. Coverage prediction by transmitters in the DL

The other coverage prediction that has been done on the selected area is by the overlapping zones.

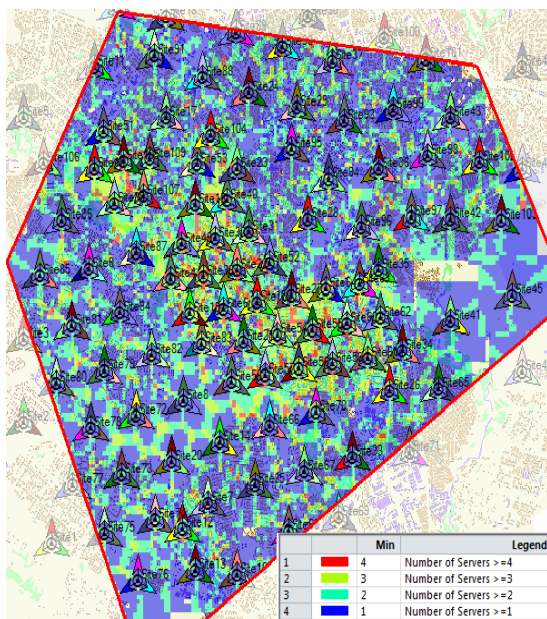

Fig. 9. Coverage prediction by the overlapping zones

After completing these coverage predictions, the final work is to show the effect of using multiple carriers in terms of increasing the number of supported active users, as compared with single carrier systems.

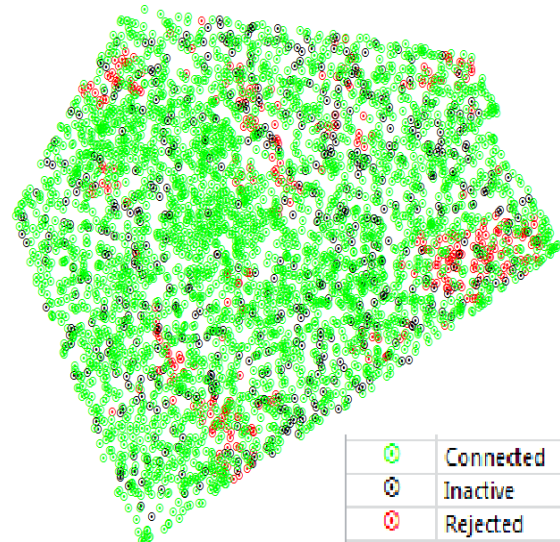

Fig. 10. State of terminal cells of Octa-cell HSPA+ system

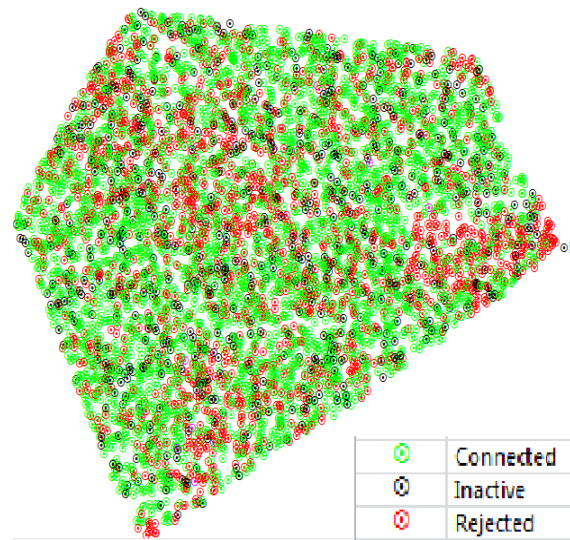

Fig. 11. State of terminal cells of single carrier UMTS/HSPA system

As it can be seen from figures 10 and 11, it can be seen that using multiple carriers will benefit in terms of supporting multiple subscribers, and also in terms of increasing the peak data rate. The network reduced the number of rejected calls at a time. This shows that the effect of deploying the Octa-cell system will bring benefits in terms of enhancing the supported number of subscribers. Even though the network operator and subscribers will benefit from using multiple carriers, there are costs that the network operator and the subscribers should satisfy. From the network operator side, additional spectrum cost is expected to be the first cost for the operator. And also, the current RNC needs hardware and software updates, and at the NodeB side there will be one additional transmit antenna. From the subscriber side, user equipments that can support a multi-carrier system will be made available. This is how this system will be successful.



## V. CONCLUSION

3GPP has initiated work on advanced-HSPA to achieve the competitiveness of UMTS/HSPA generation with respect to the growth of the HSPA subscribers. This thesis work is based on the 8 carrier enabled UMTS radio access network planning. Following the methodologies mentioned on the first chapter of the thesis, estimation and evaluation of coverage and capacity planning is done. RLB is carried out for coverage planning, and different factors that will affect RLB are considered while working on it. The required number of NodeBs for the selected area, Addis Ababa, is calculated from coverage and capacity point of view. And the larger of the two counted site values is considered as a final result. With these NodeBs and different input parameters, the simulation that shows the area with the NodeBs is displayed using Atoll 3.2 simulation software. And finally, the effect of using multiple carriers in terms of reducing the number of rejected calls is simulated by comparing it with a system which uses only a single carrier per transmitter.

## ACKNOWLEDGMENT

The authors thank Dr. Yihenew W/Senbet (Addis Ababa University) for his helpful suggestions.

## REFERENCES

- [1] Maciej Staciak, Glabouski Arkadiusz Wisniewski and Piotr Zwierzykowski, *Modeling and dimensioning of mobile networks from GSM to LTE*, 2009.
- [2] J. Lempiäinen and M. Manninen., *UMTS Radio Network Planning, Optimization, and QoS Management*, Kluwer Academic Publishers, 2004.
- [3] C. Braithwaite and M. Scott., *UMTS Network Planning and Development: Design and Implementation of the 3G CDMA Infrastructures*, 2004.
- [4] 3GPP TR 25.825, "Dual-cell High Speed Downlink Packet Access (HSDPA) operation", V1.0.0, available [www.3gpp.org](http://www.3gpp.org)
- [5] 3GPP TS 25.308, "High Speed Downlink Packet Access (HSDPA); Overall description; Stage 2 (Release 8)", 2012.
- [6] Klas Johansson, Johan Bergman, and Dirk Gerstenberger, "Multi-Carrier HSPA Evolution", *IEEE Vehicular Technology Conference, Barcelona, 2009*.
- [7] Tushar Saxena, J.S. Jadon "Review on 2G, 3G and 4G Radio Network Planning", *International Journal of Engineering, Business and Enterprise Applications (IJEBAE)*, 2013.
- [8] Mr. Santosh, G. Bari, M. Kishor, P. Jadhav, Mr. Vishal and P. Jagtap, "High Speed Packet Access", *International Journal of Engineering Trends and Technology (IJETT) – Volume 4 Issue 8, August 2013*.
- [9] Awais Saeed, Adnan A. Khan, Syed Ismail Shah, and Shariq Yasin, "Capacity Dimensioning of HSDPA Urban Network", *International Journal of Communication Networks and Information Security (IJCNIS) – Vol. 6, No. 2, August 2014*.
- [10] Johan Bergman, *HSPA Evolution: Boosting the performance of mobile broadband access*, available [www.ericsson.com](http://www.ericsson.com)
- [11] Johan Bergman, *Continued HSPA Evolution of mobile broadband*, available [www.ericsson.com](http://www.ericsson.com)
- [12] L.D. Husikyan, N.G. Grigoryan, G.T. Alaverdyan, "DC-HSDPA ROLLOUT STRATEGIES," *Proceedings of SEUA. Series "Information technologies, Electronics, Radio engineering". 2014. Issue 17, no.1*.
- [13] Xi Li, *Radio Access Network Dimensioning for 3G UMTS*, 2004.
- [14] Harri Holma, Antti Toskala and Pablo Tapia, *HSPA+ Evolution To Release 12: Performance And Optimization*, 2014 John Wiley & Sons, Ltd.
- [15] <http://www.forsk.com/atoll/>, "Atoll Overview" accessed 06 August 2015.
- [16] Anritsu, *Discover what's Possible: Understanding LTE-Advanced Carrier Aggregation*, 2013.
- [17] Qualcomm, *HSPA+ Advanced: Taking HSPA+ to the Next Level*, Qualcomm-Incorporated, 2012.
- [18] H. Holma and A. Toskala, *WCDMA for UMTS: HSPA Evolution and LTE*, 5th ed., 2007 West Sussex, UK: Wiley.
- [19] 3GPP TS 25.308 version 11.2.0 Release 11, "UMTS HSDPA: Overall description", 2012.
- [20] 4G Americas, *4G Mobile Broadband Evolution: Rel-10, Rel-11 and Beyond*, October 2012.
- [21] NSN White paper, *Long term HSPA Evolution*, March 2013.
- [22] <http://www.itu.int/en/ITU-D/Statistics/Pages/definitions/regions.aspx>, accessed 12 July 2015.
- [23] 4G Americas, *4G mobile broadband evolution: Release 10, Release 11 and beyond – HSPA+, SAE/LTE and LTE-Advanced*, October 2012.
- [24] NOMOR Research, *3GPP LTE-A Standardization in Release 12 and Beyond*, January 2013.
- [25] Harri Holma and Antti Toskala, *HSDPA/HSUPA for UMTS: High Speed Radio Access for Mobile Communications*, 2006 John Wiley and Sons, Ltd.
- [26] [http://www.enigmatic-consulting.com/Communications\\_articles/Radio\\_intro\\_article/Radio\\_intro\\_article.html](http://www.enigmatic-consulting.com/Communications_articles/Radio_intro_article/Radio_intro_article.html), "Introduction to Wireless links for Digital Communications: Radio Link Budget", accessed July 25, 2015.
- [27] Jaana Laiho, Achim Wachter and Tomas Novosa, *Radio Network Planning and Optimization for UMTS*, 2002 John Wiley and Sons, Ltd.
- [28] J. Hämäläinen, *Advanced Wireless Technologies: Antennas*, 2013.
- [29] J. Hämäläinen, *Advanced Wireless Technologies: Radio Link Budget theory & 3G HSPA*, 2013.
- [30] Tommi Heikkila, *HSDPA radio network planning*, 2006.
- [31] Nokia Siemens networks, *long term hspa evolution meets ITU-IMT advanced requirements*, White paper, April 2012.
- [32] Independent Wireless Experts, *The timing of the consumer and operator features available from HSPA and LTE*, real-wireless, January 2012.
- [33] Moe Rahnema, *UMTS Network Planning, Optimization, and Inter-Operation with GSM*, 2008, John Wiley and Sons, Ltd.
- [34] <http://www.umtsworld.com/technology/overview.htm>, "Overview of The Universal Mobile Telecommunication System", DRAFT, July 2002, accessed 12 February 2015.
- [35] 3GPP TS 25.101 version 11.3.0, *Release 11: UE Radio Transmission and Reception (FDD)*, 2013.
- [36] Qualcomm, *HSPA+ is Here! What's Next?*, Qualcomm Incorporated, March 2010.
- [37] Atoll: RF Planning and Optimization software, "Atoll Getting Started-UMTS", version 3.1.0, Forsk China, May 2011.
- [38] Nokia Siemens networks, *Mobile Broadband with HSPA and LTE: capacity and cost aspects*, White paper, 2010.
- [39] Harri Holma, and Antti Toskala, *LTE for UMTS: OFDMA and SC-FDMA Based Radio Access*, 2009 John Wiley & Sons, Ltd.



Solomon Gebru received the B.Sc. degree in electrical and computer engineering from Mekelle University, Mekelle, Ethiopia, in 2012. And he received the M.Sc. degree in communications engineering (with Very Great Distinction) from Jimma University, Jimma, Ethiopia, in 2015.

Since 2012, he has been with the Department of Biomedical Engineering, Jimma University, Jimma, Ethiopia. Currently, he is working as a lecturer in Jimma University. His research interests include wireless communications and signal processing, fourth and fifth-generation mobile and small cell technologies, telemedicine, and bio-signal processing.



Towfik Jemal received the B.Sc. degree in electrical engineering from Bahirdar University, Bahirdar, Ethiopia, in 2001 and the M.Sc. degree in computer engineering from Delhi University, New Delhi, India, in 2005, and the Ph.D. degree in wireless communication engineering from Rostock University, Rostock, Germany, in 2014.

Since 2001, he has been with the department of Electrical and Computer Engineering, Jimma University, Jimma, Ethiopia. He is also currently working as a directorate of Research and publication office of Jimma Institute of Technology, Jimma University. His research interests include wireless communication, information theory, resource optimization for wireless networks, routing protocols, sensor networks, and AD HOC networks.