

Optimal Stabilizing Controller for Boiler Flow Control using Soft Computing Technique

D. Aditya
M.tech Scholar
Gudlavalleru engineering college
Gudlavalleru, Andhra Pradesh, India

Dr. M. Siva Kumar
Professor & Head of the Department
Gudlavalleru engineering college
Gudlavalleru, Andhra Pradesh, India

Abstract - PID controllers are widely used in many industrial applications due to their simplicity and robustness. In this paper, control of steam flow parameters of the Boiler using conventional PID controllers such as Ziegler's-Nicholas, Modified Ziegler's-Nicholas & Tyreus-Luyben methods have been studied. From this study it has been found that the controller designed using conventional PID may not able to satisfy required performance criterion such as IAE, ITAE, ISE. To overcome this difficulty, in this paper a new PID controller is proposed using PSO technique. The proposed PSO-PID strategy determines the controller parameters by optimizing various performance indices such as ITAE, IAE & ISE. The comparative results (Settling time, Maximum overshoot, ITAE, IAE, ISE) shows the efficacy of the proposed method. These controllers are also simulated under different disturbances using MATLAB/Simulink and results are successfully verified.

Keywords-Fuzzy logic controller, PSO-PID, IAE, ITAE, ISE

1. INTRODUCTION

The dynamic behavior of industrial plants heavily depends on disturbances and in particular on changes in operating point.

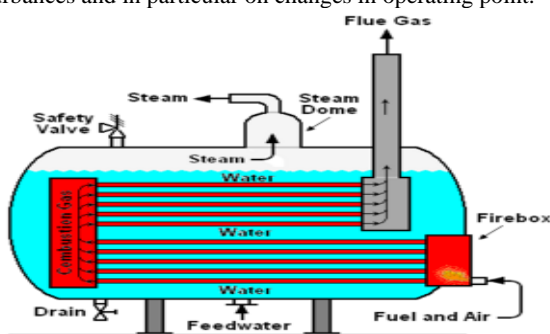

Fig1: Schematic diagram of boiler

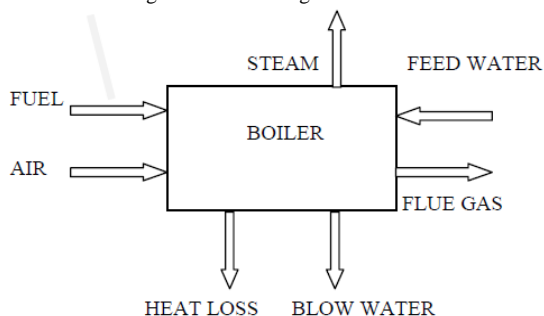

Fig 2: Basic elements of Boiler

The main input variables of a chemical plant are fuel, feed water and air. The outputs of the system are electrical power, steam pressure, steam temperature, flue gas as

Shown in fig1

In many industrial processes, control of liquid flow or temperature control is required. Boiler flow control system is a very complex system, because of nonlinearities and uncertainties in the system. There are various approaches to the design of the level controllers. The tank dynamics model based proportional integral derivative (PID) controllers have become famous for boiler level control. Conventional control approaches are not convenient to solve the complex issues in this highly nonlinear system. The control action of chemical industries maintaining the controlled variables. In this paper, control of boiler flow via three methods PID, Fuzzy Logic Controller and PSO-PID. PID control is one of the earlier control strategies. PID controller has a simple control structure which is easy to understand but the response of PID controller is not fast. To overcome these problems we use fuzzy logic and PSO-PID Controller. Performance analysis of PID, Fuzzy Logic Controller and PSO-PID has been done by the use of MATLAB and simulink. Comparison of various time domain parameters is done to prove that the PSO-PID has no overshoot, lesser settling time and lesser values for the IAE, ITAE, ISE as compared to PID and fuzzy-logic controller.

2. MATHEMATICAL MODELING

The most important aspect of any system is the theoretical analysis, which is a key for the prediction of the system being developed. A boiler of a chemical plant is taken as a case study and the temperature control of the boiler is achieved using conventional PID controller and intelligent fuzzy logic based controller. Keeping this in mind the boiler equations were formulated and toolkits like Control, design and Simulation were used in order to study the dependencies of the input variables to the output variables.

Mass balance equation for the steam in the drum:

$$d/dt (A_s.V_s) = X_r.q - q_s \dots\dots\dots (1)$$

Mass balance equation for the water in the system:

$$d/dt (A_w.V_w) = q_{fw} - q_s \dots\dots\dots (2)$$

Mass balance equation for the steam in the risers:

$$d/dt (A_s.a.V_r) = P/h_c - X_r.q \dots\dots\dots (3)$$

The circulation flow q is given by the momentum balance: $(A_w - A_s) = k.q^2 \dots\dots\dots (4)$

Set point of temperature = 380 degrees Celsius.

Where

- a average steam quality in risers (volume ratio)
- h_c evaporation enthalpy of water (J/Kg)
- k friction coefficient in down-commer riser loop
- q Circulation flow (Kg/s)

q Fw	feed water flow (Kg/s)
qs	Steam flow (Kg/s)
As	steam density (Kg/m ³)
Aw	water density (Kg/m ³)
Vr	volume of risers (m ³)
Vs	volume of steam in drum (m ³)
Vw	volume of water in drum down comer and risers (m ³)
P	power supplied to water in riser from fuel (W)
Xr	average steam quality at riser outlet (mass ratio)

2.1 Representation of system

The manipulated input output process transfer function $G(s) = C(SI - A)^{-1}B+D$ is calculated with the help of Matlab.

$$A = \begin{bmatrix} -7 & -6 & 0 \\ 1 & 0 & 0 \\ 0 & 1 & 0 \end{bmatrix}, B = \begin{bmatrix} 1 \\ 0 \\ 0 \end{bmatrix}, C = [0 \quad 5 \quad 5]$$

D = 0

N = [0 -0.0000 5.0000 5.0000]

D = [1 7 6 0]

Transfer function:

$$G(S) = \frac{5s+5}{s(s+1)(s+6)}$$

3. PROPORTIONAL – INTEGRAL -DERIVATIVE CONTROLLER

A proportional–integral–derivative controller (PID controller) is a generic control loop feedback mechanism

(Controller) widely used in industrial control systems – a PID is the most commonly used feedback controller. A PID

Controller calculates an "error" value as the difference between a measured process variable and a desired set point.

The controller attempts to minimize the error by adjusting the process control inputs. They are used in most automatic process control applications in industry. PID controllers can be used to regulate flow, temperature, pressure, level, and many other industrial process variables. Without automatic controllers, all regulation tasks will have to be done manually. For example: To keep constant the temperature of water discharged from an industrial gas-fired heater, an operator will have to watch a temperature gauge and adjust a fuel gas valve accordingly. If the water temperature becomes too high for some reason, there has to close the gas valve a bit – just enough to bring the temperature back to the desired value. If the water becomes too cold, then open the gas valve. The control task done is called feedback control, and frequently changes the firing rate based on feedback that he gets from the process via the temperature gauge. Feedback control can be done manually as described here, but it is commonly done automatically. The valve, process, and temperature gauge forms a control loop. Any change the operator makes to the gas valve affects the temperature which is fed back to the operator, thereby closing the loop.

PID controller has three control modes. They are proportional, integral, derivative and each of the three modes reacts differently to the error. The amount of response produced by each control mode is adjustable by changing the controller's tuning settings. The proportional control mode is in most cases the main driving force in a controller. It changes the controller output in proportion to the error. If the error gets bigger, the control action gets bigger. This makes a lot of sense, since more control action is needed to correct large errors. The adjustable setting for proportional control is called the Controller Gain (Kc). A higher controller gain will increase the amount of proportional control action for a given error. If the controller gain is set too

high the control loop will begin oscillating and become unstable. If the controller gain is set too low, it will not respond adequately to disturbances or set point changes. The use of proportional control alone has a large drawback – offset. Suppose increase the flow out of the tank, the tank level will begin to decrease due to the imbalance between inflow and out flow. While the tank level decreases, the error increases and our proportional controller increase the controller output proportional to this error. Consequently, the valve controlling the flow into the tank opens wider and more water flows into the tank.

As the level continues to decrease, the valve continues to open until it gets to a point where the inflow again matches the outflow. At this point the tank level (and error) will remain constant. Because the error remains constant our P-controller will keep its output constant and the control valve will hold its position. The system now remains at balance, but the tank level remains below its set point. This residual sustained error is called Offset. The effect of a sudden decrease in fuel gas pressure to the process heater described and the response of a p-only controller. The decrease in fuel-gas pressure reduces the firing rate and the heater outlet temperature decreases. This creates an error to which the controller responds. However, a new balance-point between control action and error is found and the temperature offset is not eliminated by the proportional controller. The need for manual reset as described above led to the development of automatic reset or the Integral Control Mode, as we know it today. As long as there is an error present (process variable not at set point), the integral control mode will continuously increment or decrement the controller's output to reduce the error. Given enough time, integral action will drive the controller output far enough to

reduce the error to zero. If the error is large, the integral mode will increment/decrement the controller output fast, if the error is small, the changes will be slower. For a given error, the speed of the integral action is set by the controller's integral time setting (TI). A large value of TI (long integral time) results in a slow integral action, and a small value of TI (short integral time) results in a fast integral action. If the integral time is set too long, the controller will be sluggish, if it is set too short, the control loop will oscillate and become unstable. The integral mode continues to increment the controller's output to bring the

heater outlet temperature back to its set point. The derivative control mode produces an output based on the rate of change of the error. Derivative mode is sometimes called Rate. The derivative mode produces more control action if the error changes at a faster rate. If there is no change in the error, the derivative action is zero. PID control provides more control action sooner than what is possible with P or PI control. This reduces the effect of a disturbance, and shortens the time it takes for the level to return to its set point.

3.1 PID CONTROLLER AND TUNING

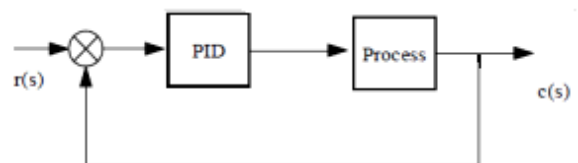

Fig 3: Block diagram of classical control structure

A feedback control system measures the output variable and sends the control signal to the controller. The controller compares the value of the output signal with a reference value and gives the control signal to the final control element via the actuator. The characteristic equation obtained as below

$$S^3 + 7S^2 + (6 + 5Kp)S + 5Kp = 0 \dots\dots\dots (1)$$

Applying Routh - Hauritz criteria in eq (1) we get $K_p = 1.68$, $\omega = 3.7947$ and $T = 1.6549$.

The equation of ideal PID controller is

$$u(t) = K_c(e(t) + \frac{1}{T_i} \int_0^t e(t)dt + T_d \frac{de(t)}{dt})$$

$$u(s) = K_c(1 + \frac{1}{T_i s} + T_d s)$$

A PID controller is tuned according to a table based on the process response test.

3.2 Tuning Methods (Closed-Loop Methods):

➤ Ziegler's-Nicholas method:

- Step 1: Reduce the integrator and derivative gains to 0.
- Step 2: Increase K_p from 0 to some critical value $K_p=K_c$ at which sustained oscillations occur
- Step 3: Note the value K_c and the corresponding period of sustained oscillation, T_c
- Step 4: Evaluate control parameters as prescribed by Ziegler and Nichols

According to Zeigler-Nichols frequency response (Closed – loop method) tuning criteria $K_p = 0.6K_{cu}$, $T_i = 0.5T$, $T_d = 0.125T$

For the PID controller in the heat exchanger, the values of tuning parameters obtained are $K_p = 1.008$, $T_i = 0.8274$, $T_d = 0.2068$ and $P = 1.008$, $I = 2.0303$, $D = 0.3474$.

➤ Modified Ziegler's-Nicholas method:

For some control loops the measure of oscillation, provide by $1/4$ decay ratio and the corresponding large overshoots for set-point changes are undesirable therefore more conservative methods are often preferable such as modified Z-N settings

According to Modified Zeigler-Nichols frequency response tuning criteria $K_p = 0.33K_{cu}$, $T_i = 0.5T$, $T_d = 0.33T$

For the PID controller in the heat exchanger, the values of tuning parameters obtained are $K_p = 0.5544$, $T_i = 0.8274$, $T_d = 0.5516$ and $P = 0.5544$, $I = 2.0304$, $D = 0.9266$.

➤ Tyreus-luyben method:

- Step 1-3: Same as steps 1 to 3 of Ziegler-Nichols method above
- Step 4: Evaluate control parameters as prescribed by Tyreus and Luyben

According to Tyreus - luyben frequency response tuning criteria $K_p = 0.45K_{cu}$, $T_i = 2.2T$, $T_d = 0.158T$

For the PID controller in the heat exchanger, the values of tuning parameters obtained are $K_p = 0.7636$, $T_i = 3.6407$, $T_d = 0.2626$ and $P = 0.7636$, $I = 0.4614$, $D = 0.4411$.

3.3 Design Of Pid-Controller

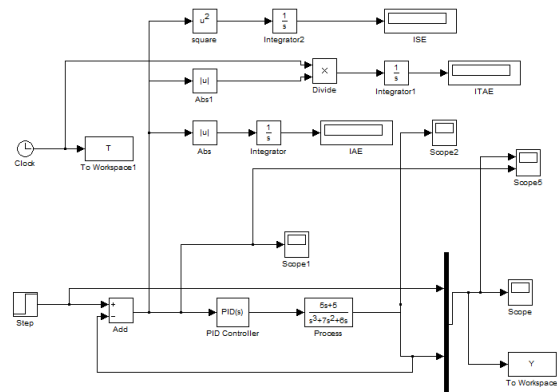

Fig 4: Simulink representation of feedback control

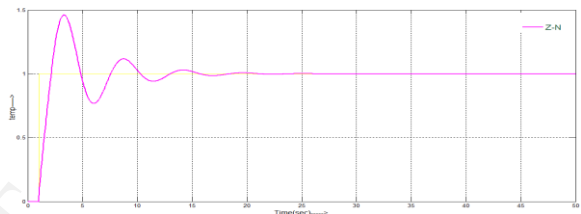

Fig 5: Step response of the gas turbine system using PID controller

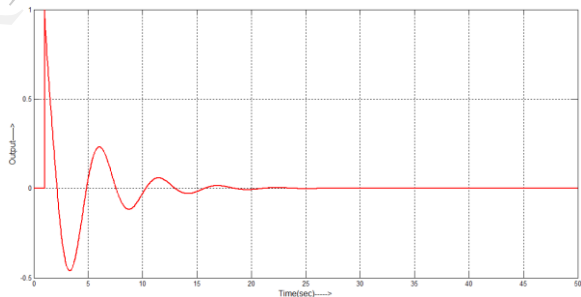

Fig 6: Graph for error signal

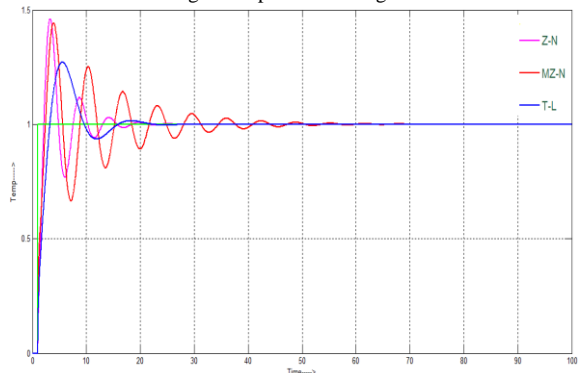

Fig 7: Step response comparison between Z-N, M Z-N & T-L methods

4. FUZZY-LOGIC CONTROLLER

By relating to the conventional PID control theory, a new fuzzy logic controller structure namely scaling factor type fuzzy logic controller is implemented. In order to improve the performance of the transient state and the steady state of the PID type controller, here developed a method to tune the scaling factor of the PID type fuzzy logic controller online. This self-tuning scaling factor shows a better performance in the transient and steady-state response. The main contribution of these variable gains in improving the control performance is that they are self-tuned gains and can adapt to rapid changes of the errors and rate of change of error caused by time delay effects, nonlinearities and uncertainties of the underlying process. The controller has to make decisions based on external temperature condition. The variable “temperature” which is inputted on the system can be divided into a range of states such as “Cold”, “Cool”, “Moderate”, “Warm”, “Hot”, “Very hot”. Defining the bounds of these states is a bit tricky. An arbitrary threshold might be used to separate “warm” from “hot”, but this would result in a discontinuous change when the input value passes over that threshold. The way to make the states “fuzzy” is to allow them change gradually from one state to the next. The input temperature states can be defined using “membership functions”.

Fuzzy-based control process consists of an input stage, processing stage and an output stage. The input stage maps sensor or other inputs such as switches, thumbwheels and so on, to an appropriate rule and generates a result for each. The processing stage then combines the results of the rules; and finally the output stage converts the combined result back to a specific control output value.

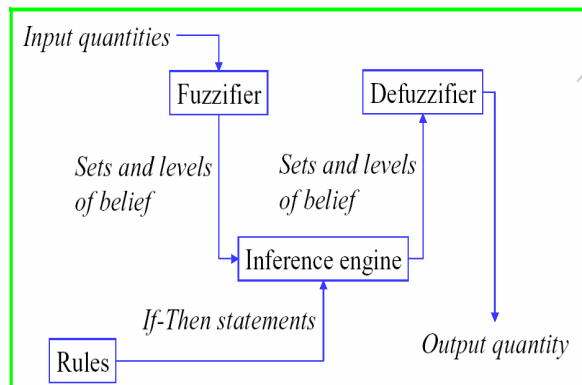

Fig8: Fuzzy inference system

The processing stage is based on a collection of logic rules in the form of If-Then statements, where the IF part is called the “antecedent” and the THEN part is called the “consequent”. These rules are used for to control the temperature in a boiler.

In this paper we have considered different linguistic variables and details of these variables are shown in table 1.

At last defuzzified output is obtained from the fuzzy inputs. In this research work centroid method of de fuzzification is used. It is given as below.

$$\mu^* = \frac{\int \mu_C(u) * u \, du}{\int \mu_C(u) \, du}$$

Table 1: IF-THEN rule base for fuzzy logic control

U(t)	e(t)							
	NL	NL	NM	NS	ZR	PS	PM	PL
Δe(t)	NL	NL	NL	NL	NL	NL	NL	NL
	NM	NL	NL	NM	NM	NS	NS	NS
	NS	NL	NM	NM	NS	NS	NS	ZR
	ZR	ZR	ZR	ZR	ZR	ZR	ZR	ZR
	PS	ZR	PS	PS	PS	PM	PM	PL
	PM	PS	PS	PS	PM	PM	PL	PL
	PL	PL	PL	PL	PL	PL	PL	PL

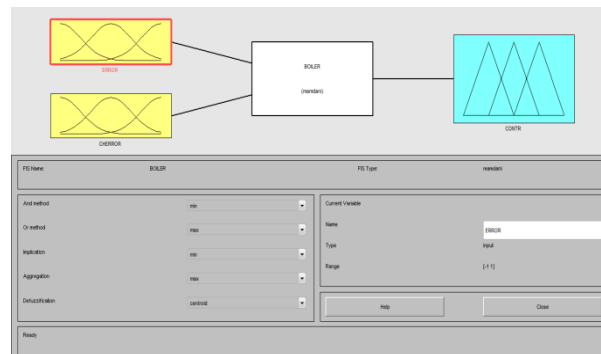

Fig 9: Mamdani fuzzy inference system developed for fuzzy controller



Fig 10: Membership functions for ERROR &CHERROR

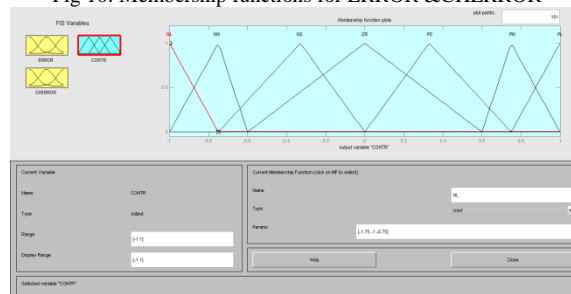

Fig11: Membership functions for CONTROLLER

4.1 DESIGN OF FUZZY - LOGIC CONTROLLER

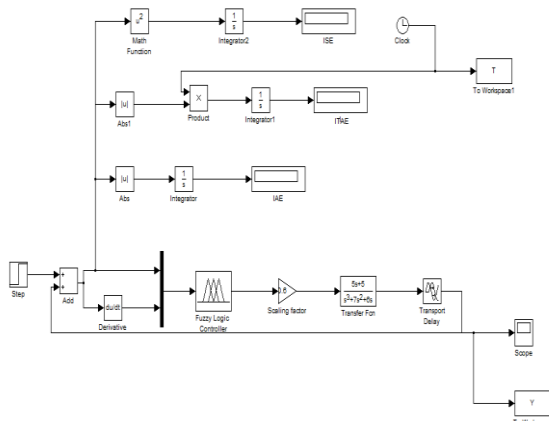

Fig 12: Simulink representation of system with fuzzy logic controller

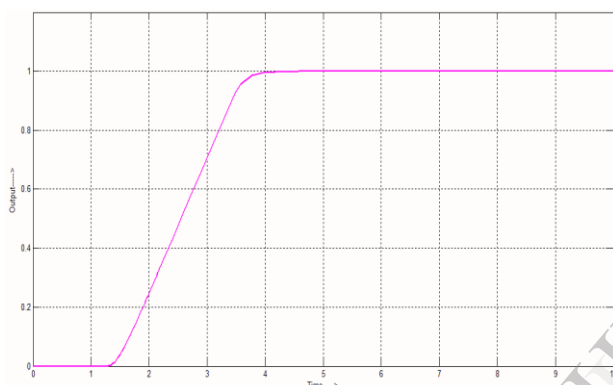

Fig 13: Step response of system with fuzzy logic controller

5. PARTICLE SWARM OPTIMIZATION

The PSO methods have been employed successfully to solve complex optimization problems. PSO first introduced by Kennedy and Eberhart is one of the modern heuristic algorithms; it has been motivated by the behavior of organisms, such as fish schooling and bird flocking. Generally, PSO is characterized as a simple concept, easy to implement, and computationally efficient. In this paper, Scheduling PSO for PID Controller parameters for a boiler temperature control is proposed. This section describes how PSO is used to design the PID controller values optimally for a boiler temperature control.

PSO is a robust stochastic optimization technique based on the movement and intelligence of swarms. PSO applies the concept of social interaction to problem solving. It uses a number of agents (particles) that constitute a swarm moving around in the search space looking for the best solution. Each particle is treated as a point in a N-dimensional. Each particle keeps track of its coordinates in the solution space which are associated with the best solution (fitness) that has achieved so far by that particle. This value is called personal best, **pbest**. Another best value that is tracked by the PSO is the best value obtained so far by any particle in the neighborhood of that particle. This value is called **gbest**. The basic concept of PSO lies in accelerating each particle toward its **pbest** and the **gbest** locations, with a random weighted acceleration at each time step as shown in Fig14.

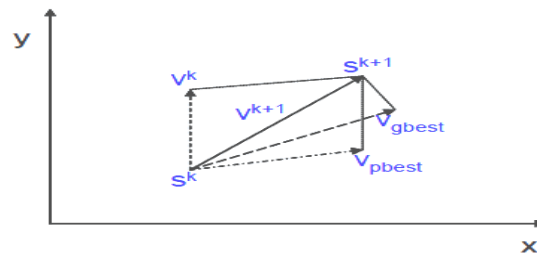

Fig 14: Concept of modification of a searching point by PSO

The modification of the particle's position can be mathematically modeled according to the following equation:

$$V_i^{k+1} = wV_i^k + c_1 \text{rand}_1(\dots) \times (pbest_i - s_i^k) + c_2 \text{rand}_2(\dots) \times (gbest - s_i^k) \dots (1)$$

5.1 Realization of Optimal PSO-PID Controller parameters

➤ Implementation of PSO Algorithm:

The optimal values of the conventional PID controller parameters K_p , K_i & K_d , is found using PSO. All possible sets of controller parameter values are particles whose values are attuned so as to minimize the objective function; here in this case is the error criterion. For the PID controller design, it is ensured the controller settings predictable results in a stable closed loop system.

➤ Performance Indices for the PSO Algorithm:

The objective function considered is based on the error performance criterion. The performance of a controller is best evaluated in terms of error criterion. A number of such criteria are available and in the proposed work, controller's performance is evaluated in terms of Integral of Absolute Error criterion, Integral of time and absolute error & Integral of square error, given by

$$IAE = \int |r(t) - y(t)| dt = \int |e(t)| dt$$

$$ITAE = \int t |e| dt \quad \& \quad ISE = \int |e^2(t)| dt$$

In this paper a time domain criterion is used for evaluating the PID controller. A set of good control parameters P, I and D can yield a good step response that will result in performance criteria minimization in the time domain. These performance criteria in the time domain include the overshoot and settling time.

5.2 Scheduling PSO for PID Controller parameters

The structure of the PID controller with PSO algorithms is shown in flowchart.

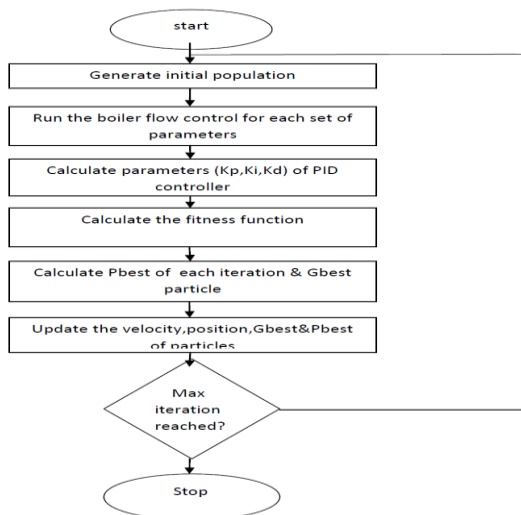

Figure 15: The flowchart of the PSO-PID control system

To control the temperature in boiler, according to the trials, the following PSO parameters (table 2) are used to verify the performance of the PSO-PID controller parameters

TABLE 2: PARAMETERS OF PSO ALGORITHMS

Population size	30
No. of iterations	30
Wmax	0.6
c1,c2	2

TABLE 3: LISTS THE Kp, Ki AND Kd OF PSO-PID CONTROLLER

CONTROLLER	Kp	Ki	Kd
PSO-PID(IAE)	8.6829	0.0922	3.1538
PSO-PID(ITAE)	27.5182	0.3598	10.8551
PSO-PID(ISE)	11.9190	0.0065	2.3954

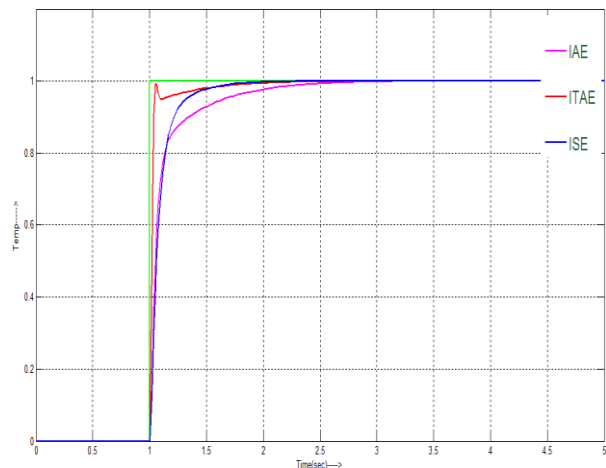

Fig 16: Step response of the PID controller tuning parameters using PSO strategy

6. RESULTS COMPARISON OF CONVENTIONAL PID CONTROLLER AND FUZZY-LOGIC CONTROLLER WITH PSO-PID CONTROLLER

To show the effectiveness of the proposed approach, a comparison is made with the designed conventional PID, Fuzzy logic controller and PSO-PID controller. These controllers are also simulated under different disturbances using MATLAB/Simulink and results are successfully verified. Finally, the steam flow parameters temperature, pressure are controlled and it is represented by using performance criteria. The performances of these controllers are listed in Table 4. It is clearly observed that PSO-PID having no overshoot, Short settling time & performance indices showing better values where conventional PID having longer settling time, higher in overshoot and also fuzzy logic controller having longer settling time, no overshoot and both of them having higher values of performance indices(IAE,ITAE&ISE).

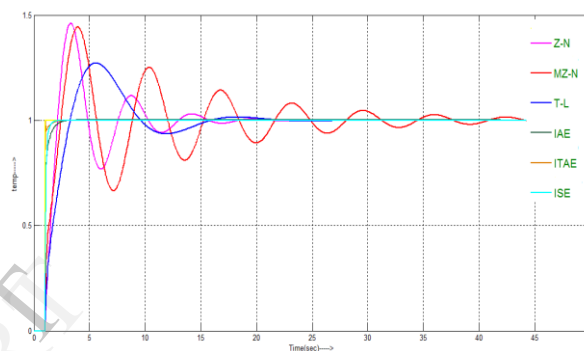

Fig17: Step response comparison between Conventional PID & PSO-PID

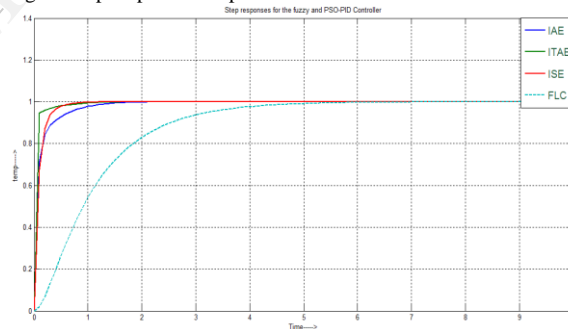

Fig18: Comparison between FLC & PSO-PID

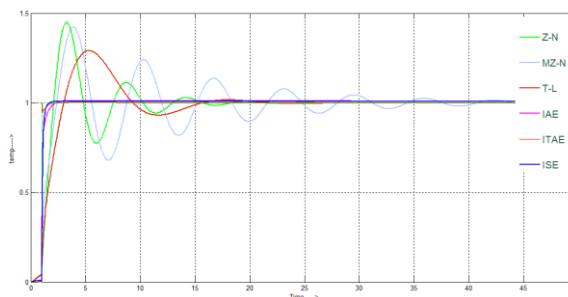

Fig19: Comparison between Conventional PID & PSO-PID (with disturbance +0.1)

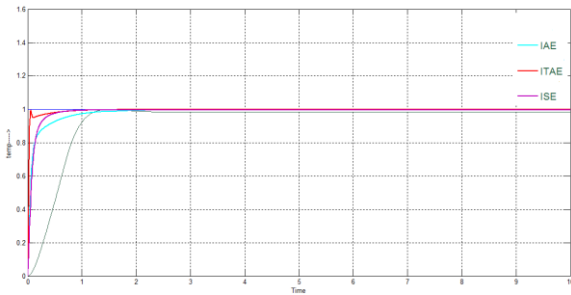

Fig20: Comparison between Fuzzy & PSO-PID (with disturbance -0.05)

7. CONCLUSION

In this paper, a process control case study taking boiler has been implemented using PSO-PID. The flow of high pressure steam to

TABLE 4: TIME-DOMAIN SPECIFICATIONS & PERFORMANCE INDICES OF SYSTEM RESPONSES WITH VARIOUS CONTROLLERS

S. No	TYPE OF DISTURBANCE	DYNAMIC PERFORMANCE SPECIFICATION & PERFORMANCE INDICES	CONVENTIONAL PID CONTROLLER			FUZZY LOGIC CONTROLLER	PSO-PID CONTROLLER		
			Z-N	MZ-N	T-L		IAE	ITAE	ISE
1	No Disturbance	Peak Overshoot (M_p) in %	46.3013	44.62	27.2681	0	0	0	0
		Settling Time (T_s) in Sec	13.9345	38.5521	13.7766	4.1352	1.052	1.14	0.505
		IAE	2.109	4.178	12.3	17.44	0.012	-	-
		ITAE	10.48	51.24	2.206	96.51	-	0.02725	-
		ISE	0.1894	0.0645	0.0048	0.0003974	-	-	0.0003352
2	A Step Disturbance of '-0.1R'	Peak Overshoot (M_p) in %	44.361	44.956	28.63	0	0	0	0
		Settling Time (T_s) in Sec	15.70	44.24	14.64	1.763	1.045	1.13	1.512
		IAE	2.221	4.372	2.311	4.721	0.07348	-	-
		ITAE	10.91	50.59	12.43	28.81	-	0.1973	-
		ISE	0.7699	0.8668	0.7632	2.78	-	-	0.05024
3	A Step Disturbance of '+0.1R'	Peak Overshoot (M_p) in %	44.36	44.352	29.91	0.6775	0	0	0
		Settling Time (T_s) in Sec	15.69	15.68	14.63	1.7684	1.046	1.12	1.613
		IAE	2.043	2.043	2.187	0.7516	0.08499	-	-
		ITAE	10.1	10.01	12.42	1.594	-	0.2258	-
		ISE	0.6415	0.6957	0.6136	0.3665	-	-	0.04693
4	A Step Disturbance of '-0.05R'	Peak Overshoot (M_p) in %	44.98	44.961	24.36	0	0	0	0
		Settling Time (T_s) in Sec	15.722	44.24	17.43	1.629	1.047	1.198	1.6147
		IAE	2.165	49.283	2.253	2.47	0.06972	-	-
		ITAE	10.169	4.247	12.34	13.44	-	0.1134	-
		ISE	0.7353	0.82	0.7145	0.9044	-	-	0.04891
5	A Step Disturbance of '+0.05R'	Peak Overshoot (M_p) in %	46.10	45.59	28.96	0.5973	0	0	0
		Settling Time (T_s) in Sec	18.76	44.26	17.475	2.103	1.999	1.1989	1.1639
		IAE	2.075	4.025	2.192	0.6166	0.08863	-	-
		ITAE	10.29	46.8	12.33	0.8541	-	0.1494	-
		ISE	0.6711	0.7344	0.6397	0.354	-	-	0.04725

the turbine is controlled by electronic governor. First of all a mathematical model of the system is developed and a conventional PID controller is implemented in it. The boiler flow control is controlled by PID-controller and fuzzy-logic controller. It has been observed that the control parameters obtained by the methods may not satisfy the performance indices such as IAE, ITAE&ISE. Then PSO-PID strategy is proposed to design and determine the optimal controller parameters for different performance indices. By comparison with PSO-PID controller, it shows that this method have improved the dynamic performance of the system in a better way. The PSO-PID controller is the best which presented satisfactory performances and possesses good robustness (such as No overshoot and shorter settling time, optimal performance indices when compared to the Conventional PID and fuzzy logiccontroller)

8. REFERENCES

1. Rahul malhotra, Rajinder Sodhi. "Boiler flow control using PID and Fuzzy logic controller", IJCSET, ISSN: 2231-0711, Vol 1, Issue6,315-319, july2011.
2. B.Hemalatha, Dr. A.Vimala Juliet, N.Natarajan "Boiler Level Control Using Lab view", International Journal of Computer Applications (0975 - 8887), Volume 1 – No. 17, March 2010.
3. Farhad Aslam, Gagandeep Kaur, "Comparative Analysis of Conventional, P, PI, PID and Fuzzy Logic Controllers for the Efficient Control of Concentration in CSTR", International Journal of Computer Applications (0975 – 8887), Volume 17– No.6, March 2011.
4. B.G. Hu, G.K.I Mann and R.G Gosine, "New methodology for analytical and optimal design of fuzzy PID controllers," IEEE Transaction of fuzzy systems, vol. 7, no. 5, pp. 521-539, 1999.
5. Mohammad Shahrokhi and Alireza Zomorodi, "Comparison of PID Controller Tuning Methods". International Journal of Advanced Technology in Engineering and Science, Volume No.02, Issue No. 11, November 2010.
6. Isizoh A. N, Okide S.O, Anazia A.E,Ogu C.D "Temperature Control System Using Fuzzy Logic Technique",International Journal of Advanced Research in Artificial Intelligence, Vol. 1, No. 3, October 2012.
7. Ritu Shakya1, Kristina Rajanwal, Sanskriti Patel and Smita Dinkar4 "Design and Simulation of PD, PID and Fuzzy Logic Controller for Industrial Application", International Journal of Information and Computation Technology, ISSN 0974-2239 Volume 4, pp. 363-368, November 2013.
8. S.N. Sivanandam1 S.N.Deepa2 "A Comparative Study Using Genetic Algorithm and Particle Swarm Optimization for Lower Order System Modelling", International Journal of Engineering Research & Technology (IJERT), ISSN: 2278-0181, Vol. 3 Issue 11, November 2014.
9. Manish Rathore , Preeti Verma , Dr Rajeev Gupta. "Tuning of PID Controller Using GA and PSO Optimization Technique and Compare with Integral Errors" International Journal of Science, Engineering and Technology Research (IJSETR), Volume 2, Issue 4, April 2013.
10. Mahmud Iwan Solihin, Lee Fook Tack, Moey Leap Kean, "Tuning of PID Controller Using Particle Swarm Optimization (PSO)", Ijert, ISBN 978-983-42366-4-9, January2011.
11. Abdullah J. H. Al Gizi, M.W. Mustafa, "Improve Fuzzy-PSO PID Controller by Adjusting Transfer Function Parameters", International Journal of Scientific and Research Publications, Volume 2, Issue 11, ISSN 2250-3153, November 2012.
12. P.Harikrishna, Prathyusha, "Optimization of main Boiler parameters using Soft computing techniques", International Journal of Research in Engineering and Technology, eISSN: 2319-1163 | pISSN: 2321-7308, January2014.