

# Power Management of a Hybrid Solar - Wind Energy System

M. Siva Ramkumar<sup>1</sup>, M. Sivaram Krishnan<sup>2</sup>

<sup>1</sup>. M.E., Assisat professor, PG scholar, Department of ECE, Sri Krishna college of Technology, Coimbatore, India

<sup>2</sup>. Department of EEE, Karpagam university, Coimbatore, India

**Abstract:** This paper presents of a hybrid solar-wind energy system which uses a DC-DC converters for conversion purpose for both solar and wind. In solar, the technique called MPPT is implemented by using a algorithm called P&O. In wind, PMSG is used as generator which eliminates the need of gear box to WECS, thereby reducing the cost of the overall system. The output can be extracted from both solar as well as from wind too. The DC-DC converter used here is of CUK & SEPIC which can act as Charge controllers, Maximum power point trackers, also used to reduce harmonic contents in the system by acting as a filtering circuit. This system can be used to run DC loads.

## I. INTRODUCTION

At presently the power production in our country mainly focused on Non renewable energy sources. i.e. almost 80% of power production is through Non renewable. But we could not meet the load demand in terms of power production. Also in future the existences of non Renewable will not be lost completely. So point to this, we are in need to move towards Renewable energy's also through it we can match the load demand too

## BLOCK DIAGRAM

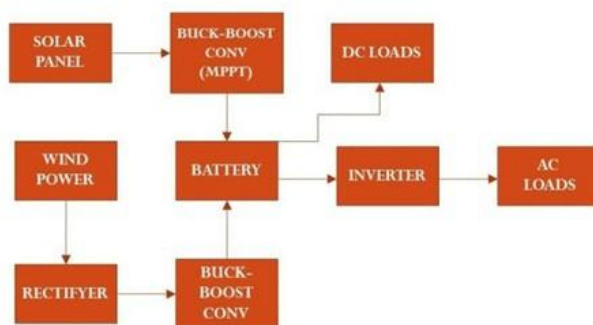

Figure 1: Block diagram of hybrid system

### A. Solar energy

Solar energy is the most readily available and free source of energy since prehistoric times. It is estimated that solar energy equivalent to over 15,000 times the world's annual commercial energy consumption reaches the earth every year. India receives solar energy in the region of 5 to 7 kWh/m<sup>2</sup> for 300 to 330 days in a year. This energy is sufficient to set up 20 MW solar power plants per square kilometer land area. [5]

### B. Windpower

Wind energy is basically harnessing of wind power to produce electricity. The kinetic energy of the wind is converted to electrical energy. When solar radiation enters the earth's atmosphere, different regions of the atmosphere are heated to different degrees because of earth curvature. Wind turbines can be used to harness the energy [3] available in airflows. Current day turbines range from around 600 kW to 5 MW [4] of rated output power. Since the power output is a function of three times of the wind speed, it increases rapidly with an increase in available wind velocity. Recent advancements have led to aerofoil wind turbines, which are more efficient due to a better aerodynamic structure.

### C.

#### Hydropower

Hydropower installations up to 10MW are considered as small hydropower and counted as renewable energy sources [7]. These involve converting the potential energy of water stored in dams into usable electrical energy through the use of water turbines. Run-of-the-river hydroelectricity aims to utilize the kinetic energy of water without the need of building reservoirs or dams.

### D.

#### Biomass

Plants capture the energy of the sun through the process of photosynthesis. On combustion, these plants release the trapped energy. This way, biomass works as a natural battery to store the sun's energy [8] and yield it on requirement.

### E. Geothermal

Geothermal energy is the thermal energy which is generated and stored [9] within the layers of the Earth. The gradient thus developed gives rise to a continuous conduction of heat from the core to the surface of the earth. This gradient can be utilized to heat water to produce superheated steam and use it to run steam turbines to generate electricity. The main disadvantage of geothermal energy is that it is usually limited to regions near tectonic plate boundaries, though recent advancements have led to the propagation of this technology [10].

## II. NEED OF HYBRID SYSTEM

**Hybrid renewable energy systems (HRES)** is the combination of two or more renewable energy sources used together to provide improved system efficiency as well as good balance in energy supply.

## III. CHARACTERISTICS OF HYBRID ENERGY SYSTEMS

The characteristics and components of a hybrid system depend greatly on the application. The most important consideration is whether the system is isolated or connected to a central utility grid.

### A. Central Grid Connected Hybrid Systems

If the hybrid system is connected to a central utility grid, as in a DG application, then the design is simplified to a certain degree and the number of components may be reduced. This is because the voltage and frequency are set by the utility system and need not be controlled by the hybrid system. In addition, the grid normally provides the reactive power. When more energy is required than supplied by the hybrid system the deficit can be in general be provided by the utility. Similarly, any excess produced by the hybrid system can be absorbed by the utility. In some cases, the grid does not act as an infinite bus, however. It is then said to be „weak. „Additional components and control may need to be added. The grid connected hybrid system will then come to more closely resemble an isolated one.

### B. Isolated Grid Hybrid Systems

Isolated grid hybrid systems differ in many ways from most of those connected to a central grid. First, they must be able to provide for all the energy that is required at any time on the grid or find a graceful way to shed load when they cannot. They must be able to set

the grid frequency and control the voltage. The latter requirement implies that they must be able to provide reactive power as needed. Under certain conditions, renewable generators may produce energy in excess of what is needed.[5].

## IV. DC-DC CONVERTER

Types of dc-dc converter circuits,

1. Buck,
2. Boost and
3. Buck-boost. and special type of converters named as
- 4.CUK
- 5.SEPIC

DC to DC converters are used for converting one level of DC voltage unregulated into another level of DC voltage(regulated) . It consists of storage elements like inductor ,capacitor and power semiconductor devices like transistors and diodes.It plays the role of Charge controllers, Maximum power point trackers , also used to reduce harmonic contents in the system by acting as a filtering circuits. The output voltage can be either higher or lower than input voltage

### A. Buck Converter

Features of a buck converter are

- Pulsed input current, requires input filter.
- Continuous output current .
- Output voltage is always less than input voltage. [5]

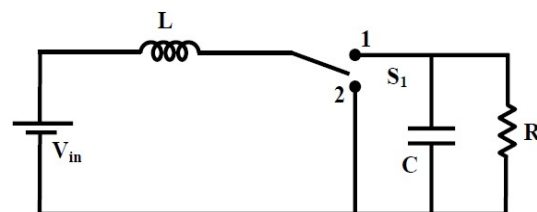
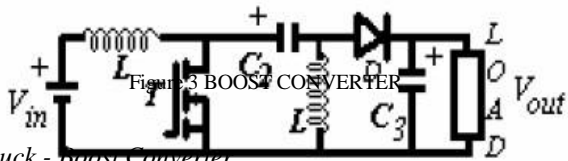

Figure 2: BUCK CONVERTER

### B. Boost Converter

Features of a boost converter are

- Continuous input current, eliminates input filter.
- Pulsed output current.
- Output voltage is always greater than input voltage [5].



C. Buck - Boost Converter

- Pulsed output current increases output voltage ripple Output voltage can be either greater or smaller than input voltage [5].

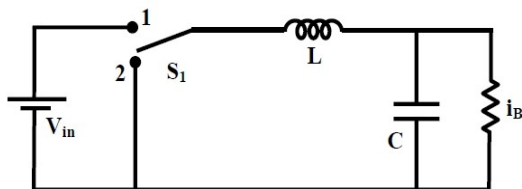

Figure 4 BUCK-BOOST CONVERTER

D. Cuk Converter

It will be desirable to combine the advantages of these basic converters into one converter. CuK converter is one such converter. It has the following advantages.

- Continuous input current. & Continuous output current.
- Output voltage can be either greater or less than input voltage.

CuK converter is actually the cascade combination of a boost and a buck converter. The CUK converter as the dual of the Buck-Boost converter has current input and current output stages [5].

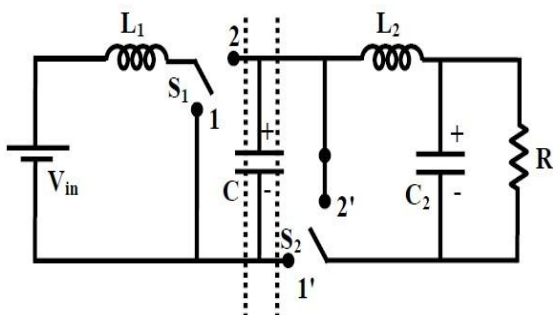

Figure 5: CUK CONVERTER

E. The Sepic Converter

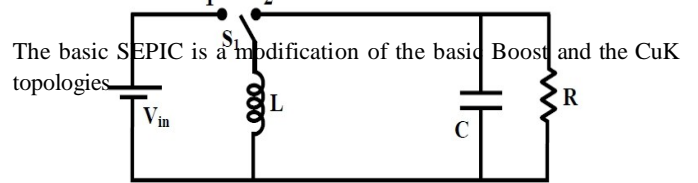

Figure 6 SEPIC CONVERTER

The SEPIC officially stands for “Single-Ended Primary Inductance Converter”. However, the unofficial interpretation is more descriptive: “Secondary Polarity Inverted Cuk”. Thus the SEPIC is also basically a BOOST BUCK converter akin to the CUK converter. In the practical SEPIC converter, the two inductors are coupled with the polarities as indicated by dots in Fig 6

The turn’s ratio is and the coupling is very tight. For such a coupled-transformer SEPIC.

V. MAXIMUM POWER POINT TRACKING

A. An overview of maximum power point tracking

A typical solar panel converts only 30 to 40 percent of the incident solar irradiation into electrical energy. Maximum power point tracking technique is used to improve the efficiency of the solar panel. According to Maximum Power Transfer theorem, the power output of a circuit is maximum when the Thevenin impedance of the circuit (source impedance) matches with the load impedance. Hence our problem of tracking the maximum power point reduces to an impedance matching problem. In the source side we are using a boost converter connected to a solar panel in order to enhance the output voltage so that it can be used for different applications like motor load. By changing the duty cycle of the boost converter appropriately we can match the source impedance with that of the load impedance. [16]

B. Different MPPT Techniques

There are different techniques used to track the maximum power point. Few of the most popular techniques are:

- Perturb and observe (hill climbing method)
- Incremental Conductance method
- Fractional short circuit current
- Fractional open circuit voltage
- Neural networks
- Fuzzy logic

Here I have chosen perturb and observe method

C. Perturb & observe:

Perturb & Observe (P&O) is the simplest method. In this we use only one sensor, that is the voltage sensor, to sense the PV array voltage and so the cost of implementation is less and hence easy to implement. The time complexity of this algorithm is very less but on reaching very close to the MPPT it doesn't stop at the MPPT and keeps on perturbing on both the directions.

However, in this algorithm we use only one sensor, that is the voltage sensor, to sense the PV array voltage and so the cost of implementation is less and hence easy to implement. The time complexity of this algorithm is very less but on reaching very close to the MPPT it doesn't stop at the MPPT and keeps on perturbing in both the directions.

VI. SIMULATION MODEL AND RESULTS

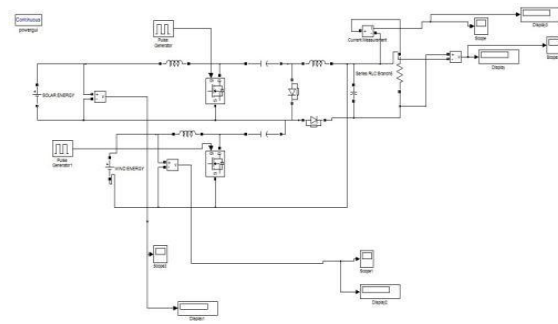

Figure 9: Simulation Design Model

If both solar-wind is available, the output would be in the range of 4.1kw, if either solar or wind is alone available means, the output would in the range of 4kw. because we have used CUK-SEPIC as converter configuration. These are comes under special DC-DC converter type. These are special converters because no need for additional filters. Since they have continuous output and input current characteristics which eliminate additional filters for ripple and etc.

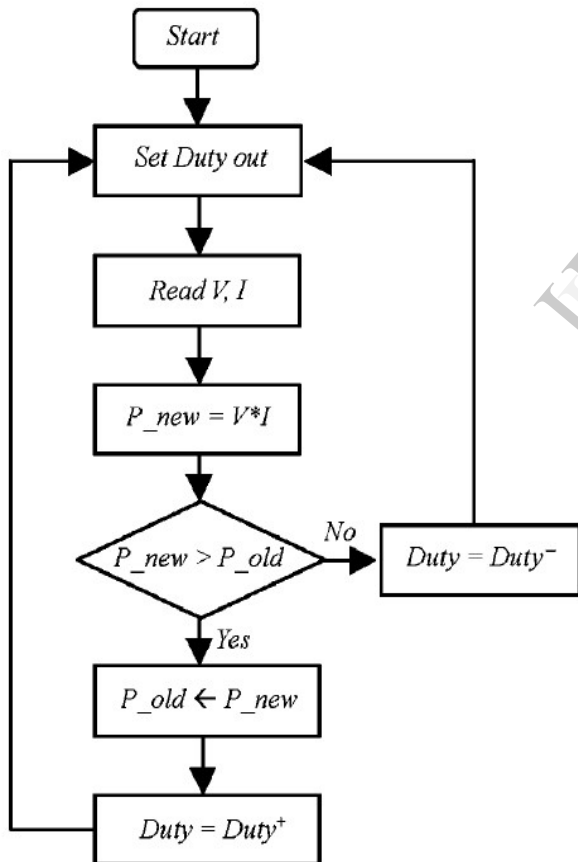

Figure 8: FLOW CHART FOR P & O

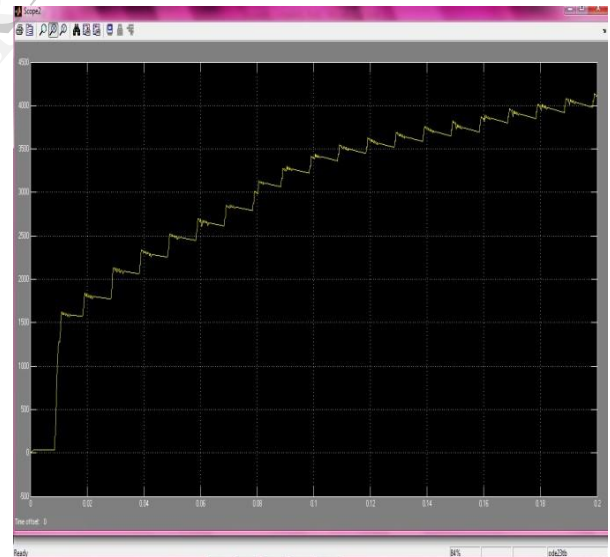

Figure 10. Output voltage

Through simulation it is clear that we can reach 4.1kw of power through this system model. also it is clear that the output voltage will be constant throughout the process.

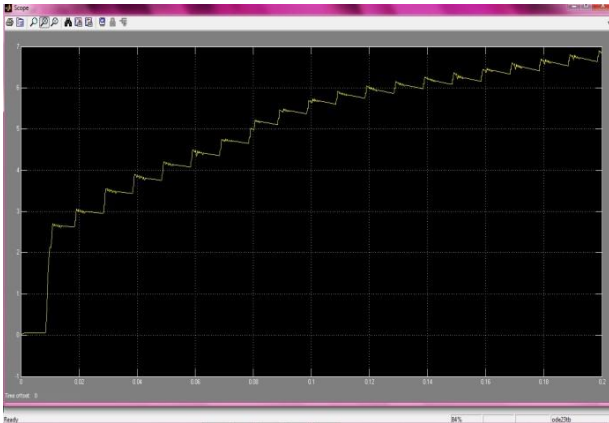

Figure 11 :Output Current

## VII. WIND TURBINE GENERATOR

There are two types of generators used in WECS, They are

- INDUCTION GENERATOR
- SYNCHRONOUS GENERATOR

Here synchronous generator is preferred because of its advantages. If we need to use induction generators means,

Reactive power suppliers like capacitor banks is to be included in the system, thereby increase cost of the system. The pole pitch of Synchronous generator can be smaller than others in order to reduce the mechanical losses of machine and improve to the reliability of the system This can be done by increasing the number of poles of the machine and decreasing its nominal speed of the generator. Thereby this way, gearbox can be eliminated and the wind turbine system becomes more efficient and reliable.



M.Siva Ramkumar<sup>1</sup>, M.E., Assisant professor  
Department of EEE  
Karpagam university  
Coimbatore, India



M.Sivaram Krishnan<sup>2</sup>, PG scholar  
Department of ECE  
Sri Krishna college of Technology  
Coimbatore, India

## VIII. CONCLUSION

The system gives a new combination of energy system. Here we used wind and solar as a hybrid source, either of them will be available in 24\*7 thus it can be used as sources. This system gives a continuous output. , if either solar or wind is alone available means, the output would in the range of 4kw or else if both are available the output can be further improved to 5kw, since MPPT technique is available. Also CUK-SEPIC configuration DC-DC converter do not need additional filters, so it reduces the cost and improves the power efficiency of the system.

## REFERENCE

- [1] Resource and Energy Economics - C Withagen - 1994 – Elsevier
- [2] SemanaScientifica - L Pedroni - 2004 - Google Books
- [3] Wind power in Power Systems (Book) - T Ackermann - 2005 – Wiley
- [4] Analysis of Wind Energy in the EU-25 - European Wind Energy Association – 2007
- [5] Solar Power (Book) - T Harko
- [6] Harnessing Solar Power (Book) - K Zweibel – 1990. [7] REN21 Renewables 2010 Global Status Report
- [8] “How biomass energy works” - Union of Concerned Scientist
- [9] Geothermal Energy: Renewable Energy and the Environment - William E. Glassley – CRC Press – 2010
- [10] Impact of Enhanced Geothermal Systems (Egs) on the United States in the 21st Century: An Assessment - Tester, Jefferson W. et. al. - 2006
- [11] Dynamic Modelling and Control of a Grid-Connected Hybrid Generation System with Versatile Power Transfer
- [12] Harmonic mitigation in wind turbine energy conversion systems
- [13] Some topologies of high quality rectifiers
- [14] Hybrid EnergySystemsJ. F. MANWELL University of Massachusetts Amherst, Massachusetts, United States
- [15] Version 2 EE IIT, Kharagpur E- NOTES
- [16] STUDY OF MAXIMUM POWER POINTTRACKING (MPPT) TECHNIQUES IN A SOLAR PHOTOVOLTAIC ARRAY Department of Electrical Engineering National Institute of Technology Rourkela