

Power Quality Improvement of Grid Interconnected 3-phase 4-wire Distribution System using Fuzzy logic control

A.Ananda Kumar, J.Srinivasa Rao.

Abstract—This paper presents a grid interfacing inverter that compensates power quality problems and it can also interface renewable energy sources with the electric grid. The grid interfacing inverter can effectively be utilized to perform following functions: 1) transfer of active power harvested from the renewable resources; 2) load reactive power demand support; 3) current harmonic compensation at PCC; and 4) current unbalance and neutral current compensation in case of 3-phase 4-wire system. The ability of fuzzy logic to handle rough and unpredictable real world data made it suitable for a wide variety of applications, especially, when the models or processes are too complex to be analyzed by classical methods. In this paper fuzzy logic controller is used for controlling the DC capacitor voltage. Simulations using MATLAB / SIMULINK are carried out to verify the performance of the proposed controller. The results show that the proposed controller has fast dynamic response, high accuracy of tracking the DC-voltage reference, and strong robustness to load parameters variation.

Keywords— Active power filter, Distributed generation, Grid interconnection.

I. INTRODUCTION

The greenhouse gases such as carbon dioxide absorb the infrared radiation and trap the heat in the Earth's atmosphere. These greenhouse gases emissions come primarily from the combustion of fossil fuels in energy use [1]. The impact of the traditional fossil fuels in our environment and the fact that these are non renewable sources, have encouraged the need to find alternative energy sources to the fossil fuel. Therefore, the renewable energy sources have been one of the most important topics of research in the last years. They are constantly replenished and will never run out [2].

Renewable energy source (RES) integrated at distribution level is termed as distributed generation (DG). The utility is concerned due to the high penetration level of intermittent RES in distribution systems as it may pose a threat to network in terms of stability, voltage regulation and power-quality (PQ) issues. Therefore, the DG systems are required to comply with strict technical and regulatory frameworks to ensure safe, reliable and efficient operation of overall network. With the advancement in power electronics and digital control technology, the DG systems can now be actively controlled to enhance the system operation with improved PQ at PCC.

However, the extensive use of power electronics based equipment and non-linear loads at PCC generate harmonic currents, which may deteriorate the quality of power [3]-[5].

The widespread increase of non-linear loads nowadays, significant amounts of harmonic currents are being injected into power systems. Harmonic currents flow through the power system impedance, causing voltage distortion at the harmonic currents' frequencies. The distorted voltage waveform causes harmonic currents to be drawn by other loads connected at the point of common coupling (PCC). The existence of current and voltage harmonics in power systems increases losses in the lines, decreases the power factor and can cause timing errors in sensitive electronic equipments.

The harmonic currents and voltages produced by balanced 3-phase non-linear loads such as motor drivers, silicon controlled rectifiers (SCR), large uninterruptible power supplies (UPS) are positive-sequence harmonics (7th, 13th, etc.) and negative-sequence harmonics (5th, 11th, etc.). However, harmonic currents and voltages produced by single phase non-linear loads such as switch-mode power supplies in computer equipment which are connected phase to neutral in a 3-phase 4-wire system are third order zero-sequence harmonics (triplen harmonics—3rd, 9th, 15th, 21st, etc.). These triplen harmonic currents unlike positive and negative-sequence harmonic currents do not cancel but add up arithmetically at the neutral bus. This can result in neutral current that can reach magnitudes as high as 1.73 times the phase current. In addition to the hazard of cables and transformers overheating the third harmonic can reduce energy efficiency. [6]

The traditional method of current harmonics reduction involves passive LC filters, which are its simplicity and low cost. However, passive filters have several drawbacks such as large size, tuning and risk of resonance problems. The increased severity of harmonic pollution in power networks has attracted the attention of power electronics and power system engineers to develop dynamic and adjustable solutions to the power quality problems. Such equipment, generally known as active filters (AF's) [7], Active power filters (APF) are extensively used to compensate the load current harmonics and load unbalance at distribution level. This results in an additional hardware cost. However, in this paper authors have incorporated the features of APF in the, conventional inverter interfacing renewable with the grid, without any additional hardware cost. That conventional inverter is called as a "grid interfacing inverter". The inverter is controlled to perform as a

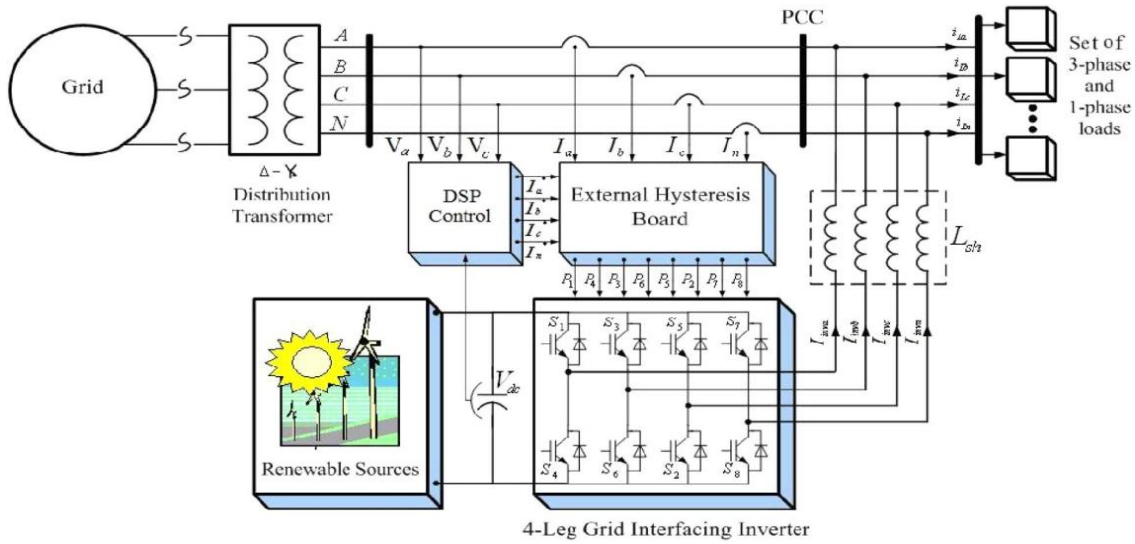

Fig. 1. Schematic of proposed renewable based distributed generating system

multifunction device by incorporating active power filter functionality. The inverter can thus be utilized as: 1) power converter to inject power generated from RES to the grid, and 2) shunt APF to compensate current unbalance, load current harmonics, load reactive power demand and load neutral current. All of these functions may be accomplished either individually or simultaneously.

II. SYSTEM DESCRIPTION

In this paper, it is shown that using an adequate control strategy, with a four-leg four-wire grid interfacing inverter, it is possible to mitigate disturbances like voltage unbalance. The topology of the investigated grid interfacing inverter and its interconnection with the grid is presented in Fig. 1. It consists of a four-leg four-wire voltage source inverter. The voltage source inverter is a key element of a DG system as it interfaces the renewable energy source to the grid and delivers the generated power. In this type of applications, the inverter operates as a current controlled voltage source. Fourth leg is used for neutral connection. The RES may be a DC source or an AC source with rectifier coupled to dc-link. In this paper wind energy is used as a RES, the variable speed wind turbines generate power at variable ac voltage. Thus, the power generated from these renewable sources needs to convert in dc before connecting on dc-link [8]–[10]. The simulink model of wind farm is given in Fig2. Wind farm generates a variable ac supply; this variable ac supply is converted into dc by connecting a rectifier at output side.

A. CONTROL STRATEGY

The controller requires the three-phase grid current (I_a, I_b, I_c), the three-phase voltage at the PCC (V_a, V_b, V_c) and the DC-link voltage (V_{DC}). As shown in Fig. 3, the sinusoidal waveform and the phase of the grid current reference (I_a^*, I_b^*, I_c^*) comes from the line voltage thanks to a PLL.

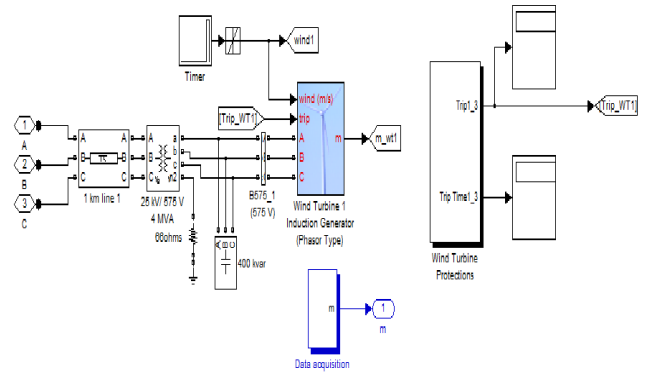

Fig. 2. simulink diagram of wind farm.

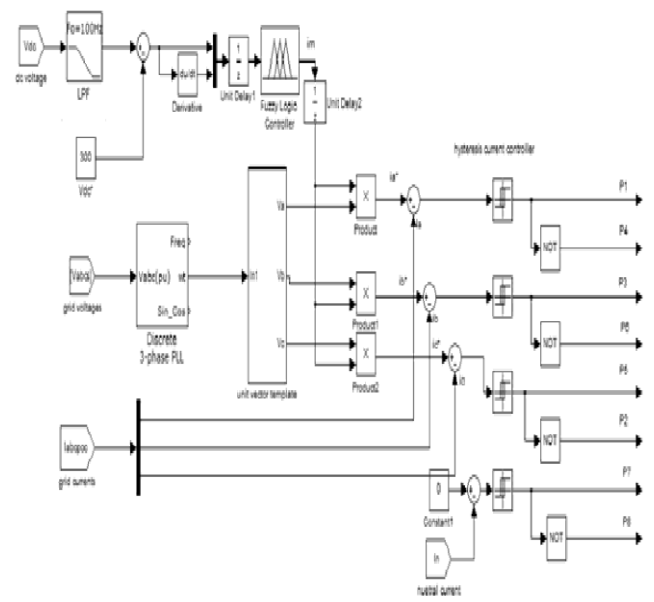

Fig. 3. Representation of grid interfacing inverter control

$$U_a = \sin(\theta) \tag{1}$$

$$U_b = \sin(\theta - 2\pi/3) \tag{2}$$

$$U_c = \sin(\theta + 2\pi/3) \tag{3}$$

The magnitude I_m of the same current is obtained by passing the error signal between the DC-link voltage (V_{DC}) and a reference voltage (V_{DC}^*) through a fuzzy logic controller. Using this magnitude and phase displacement of 120° and 240° respectively, the reference three-phase grid currents i_a^*, i_b^* and i_c^* can be expressed as:

$$I_a^* = I_m \sin(\theta) \tag{4}$$

$$I_b^* = I_m \sin(\theta - 2\pi/3) \tag{5}$$

$$I_c^* = I_m \sin(\theta + 2\pi/3) \tag{6}$$

B. FUZZY LOGIC CONTROLLER (FLC)

The disadvantage of PI controller is its inability to react to abrupt changes in the error signal, ϵ , because it is only capable of determining the instantaneous value of the error signal without considering the change of the rise and fall of the error, which in mathematical terms is the derivative of the error denoted as $\Delta\epsilon$. To solve this problem,[11][12] Fuzzy logic control as it is shown in Fig 4 is proposed.

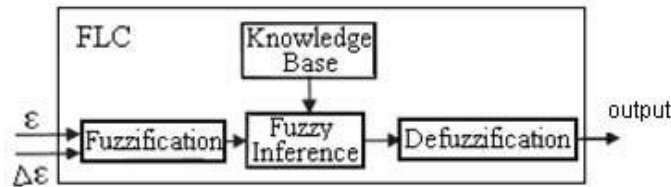

Fig.4.Basic representation of FLC

The determination of the output control signal, is done in an inference engine with a rule base having if-then rules in the form of

"IF ϵ is AND $\Delta\epsilon$ is, THEN output is"

With the rule base, the value of the output is changed according to the value of the error signal ϵ , and the rate-of-error $\Delta\epsilon$. The structure and determination of the rule base is done using trial-and-error methods and is also done through experimentation.

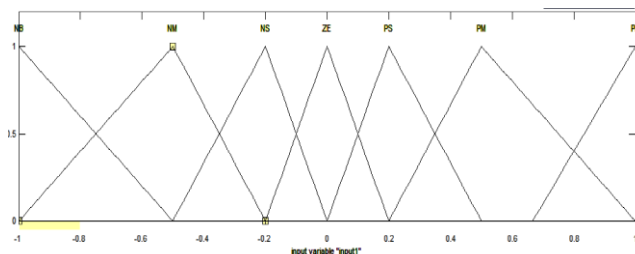

Fig.5.Membership functions of input ϵ

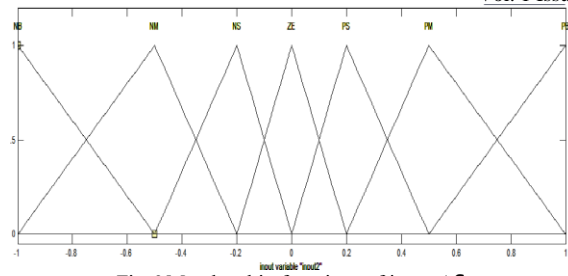

Fig.6.Membership functions of input $\Delta\epsilon$

TABLE I. FLC RULE BASE

ϵ $\Delta\epsilon$	NB	NM	NS	ZE	PS	PM	PB
NB	NB	NB	NB	NB	NM	NS	ZE
NM	NB	NB	NM	NM	NS	ZE	PS
NS	NB	NM	NS	NS	ZE	PS	PM
ZE	NB	NM	NS	ZE	PS	PM	PB
PS	NM	NS	ZE	PS	PS	PM	PB
PM	NS	ZE	PS	PM	PM	PB	PB
PB	ZE	PS	PM	PB	PB	PB	PB

All the variables' fuzzy subsets for the inputs ϵ and $\Delta\epsilon$ are defined as (NB, NM, NS, Z, PS, PM, PB). The membership function of inputs is illustrated in fig.5&6. The fuzzy control rule is illustrated in the table I.

C. SWITCHING CONTROL

As shown in Fig. 3, the hysteresis control has been used to keep the controlled current inside a defined band around the references. The status of the switches is determined according to the error. When the current is increasing and the error exceeds a certain positive value, the status of the switches changes and the current begins to decrease until the error reaches a certain negative value. Then, the switches status changes again. Compared with linear controllers, the non-linear ones based on hysteresis strategies allow faster dynamic response and better robustness with respect to the variation of the non-linear load. A drawback [13] [14] of the hysteresis strategies is the switching frequency which is not constant and can generate a large side harmonics band around the switching frequency.

III. SIMULATION RESULTS

An extensive simulation study is carried out using MATLAB/Simulink in order to verify the proposed control strategy. To achieve balanced sinusoidal grid currents at unity power factor, the 4-leg grid interfacing inverter is actively controlled under varying renewable generating condition. The

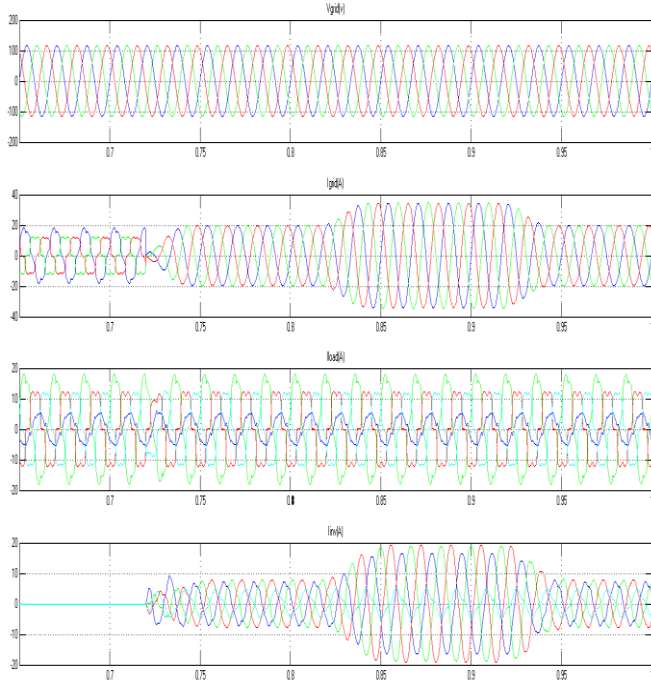

Fig.7. simulation results:(a)grid voltages, (b) grid currents, (c) load currents,(d) inverter currents

wave forms of grid voltages, grid currents, unbalanced load current and inverter currents are shown in Fig.7. The corresponding active and reactive of grid (PQ grid), load (PQ load) and inverter (PQ inv) are shown in Fig.8. Positive values of grid active-reactive powers and inverter active-reactive powers imply that these powers flow from grid side towards PCC and from inverter towards PCC, respectively. The active and reactive powers absorbed by the load are denoted by positive signs.

Before $t=0.72s$, the grid interfacing inverter is not connected to network, hence the grid currents in Fig.7 (b) are same as unbalanced nonlinear load currents Fig.7(c).

At $t=0.72s$, the grid interfacing inverter is now connected to network. The grid current starts changing to sinusoidal balanced from unbalanced nonlinear current shown in Fig.7 (b). At this instant active power injected by the inverter from RES. From Fig.8. The load power demand is less than the generated power and the additional power is fed back to the grid. The grid is receiving power from RES after 0.72s and it is indicated by -ve sign.

At $t=0.82s$, considering the load power demand as constant. The power generated from RES is increased to verify the system performance under variable power generation and hence it increases the magnitude of inverter current.

At $t=0.92s$ generation of power from RES is reduced. The active and re-active power flows between the inverter, load and grid during increase and decrease of energy generation from RES can be noticed from Fig. 8. Observing fig.8&9. It is clear that the fuzzy controller has high accuracy and fast response to load parameter variation.

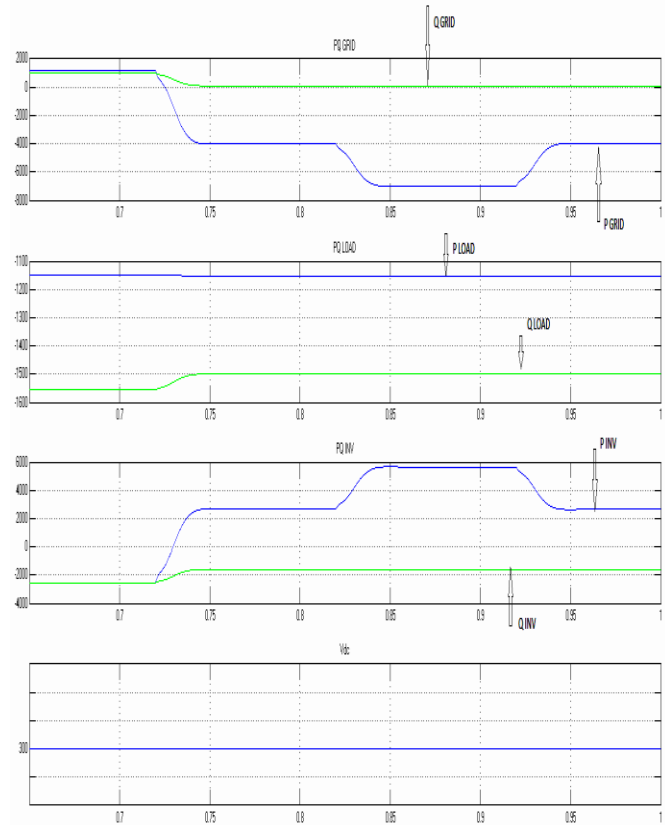

Fig.8.simulation results: (a) PQ grid, (b) PQ load, (c) PQ inverter, (d) dc link voltage using fuzzy controller

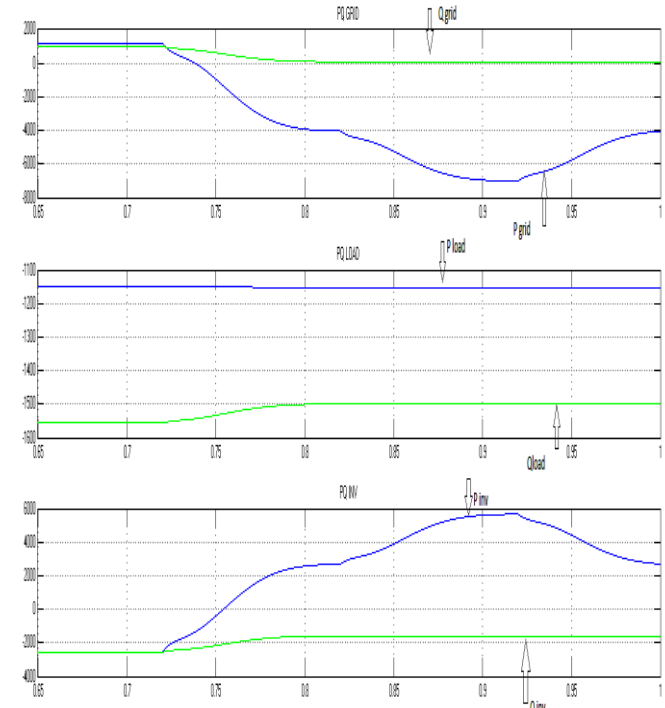

Fig.9.simulation results: (a) PQ grid, (b) PQ load, (c) PQ inverter using PI controller

IV. CONCLUSION

This paper has presented a novel method to improve the power quality at point of common coupling (PCC) for a 3-phase 4-wire DG system using fuzzy logic control for grid interfacing inverter. The grid interfacing inverter is effectively utilized for power conditioning. This approach eliminates the additional power conditioning equipment to improve power quality at PCC. Simulation results analysis has shown that the proposed controller has fast response, high accuracy of tracking the DC-voltage reference, and strong robustness to load sudden variations

REFERENCES

- [1] Energy Information Administration, "Greenhouse Gases, Climate Change, and Energy", <http://www.eia.doe.gov/bookshelf/brochures/greenhouse/Chapter1.htm> Accessed: 19 March 2009.
- [2] National Renewable Energy Laboratory, "Learning About Renewable Energy" <http://www.nrel.gov/learning/> Accessed: 19 January 2009.
- [3] J. M. Guerrero, L. G. de Vicuna, J. Matas, M. Castilla, and J. Miret, "A wireless controller to enhance dynamic performance of parallel inverters in distributed generation systems," *IEEE Trans. Power Electron.*, vol. 19, no. 5, pp. 1205–1213, Sep. 2004.
- [4] J. H. R. Enslin and P. J. M. Heskes, "Harmonic interaction between a large number of distributed power inverters and the distribution network," *IEEE Trans. Power Electron.*, vol. 19, no. 6, pp. 1586–1593, Nov. 2004.
- [5] Telmo Santos, J.G.Pinto, P.Neves, D.Goncalves, Joao L. Afonso, "comparison of three control theories for single phase active filters," *IEEE Ind. Electron. Society*, Nov. 2009.
- [6] Mehmet Ucar, Engin Ozdemir "Control of a 3-phase 4-leg active power filter under non-ideal mains voltage condition" *Electric Power Systems Research* 78 (2008) 58–73.
- [7] Bhim Singh, Kamal Al-Haddad, *Senior Member, IEEE*, and Ambrish Chandra, *Member, IEEE* "A Review of Active Filters for Power Quality Improvement," *IEEE Trans. Ind. Elec-tron.*, vol. 46, no. 5, Sep. 1999.
- [8] F. Blaabjerg, R. Teodorescu, M. Liserre, and A. V. Timbus, "Overview of control and grid synchronization for distributed power generation systems," *IEEE Trans. Ind. Electron.*, vol. 53, no. 5, pp. 1398–1409, Oct. 2006.
- [9] J. M. Carrasco, L. G. Franquelo, J. T. Bialasiewicz, E. Galván, R. C. P. Guisado, M. Á. M. Prats, J. I. León, and N. M. Alfonso, "Power-electronic systems for the grid integration of renewable energy sources: A survey," *IEEE Trans. Ind. Electron.*, vol. 53, no. 4, pp. 1002–1016, Aug. 2006.
- [10] B. Renders, K. De Gussemé, W. R. Ryckaert, K. Stockman, L. Vandevelde, and M. H. J. Bollen, "Distributed generation for mitigating voltage dips in low-voltage distribution grids," *IEEE Trans. Power. Del.*, vol. 23, no. 3, pp. 1581–1588, Jul. 2008.
- [11] Rachid Dehini, Brahim Ferdi "STATCOM Dc-bus Voltage Controller Based on Fuzzy logic" *IJAEST* vol.11.,pp.281-285.
- [12] M.Bhanu Siva, M.R.P Reddy, Ch.Rambabu "Power Quality Improvement of Three-phase four-wire DSTATCOM with Fuzzy logic Controller" *ICSIT*, vol.2, pp. 2273-2273., 2011.
- [13] M. Nejad, S. Pierfederici, J.P. Martin, F. Meibody-Tabar, "Study of an hybrid current controller suitable for DC–DC or DC–AC applications," *IEEE Transactions on Power Electronics*, vol. 22, pp. 2176–2186. November 2007.
- [14] Copper Development Association, "Voltage Disturbances. Standard EN50160 Voltage Characteristics in Public Distribution Systems," 2004.



Annavarapu Ananda Kumar born in 1987, in India. He received B.Tech degree in Electrical & Electronics Engineering from Acharya Nagarjuna University, India in 2008. Currently he is pursuing M.Tech degree from JNTU University in Power System Control & Automation. His research interest includes Power Systems, Power System Operation & Control, Power System Stability & Analysis.



SRINIVASARAO.J is an associate professor in QIS College of Engineering & Technology at Ongole. He is a Ph.D candidate. He got his M-Tech degree from JNTU Hyderabad and his B-Tech degree from RVRJC Engineering College, Guntur. His current research interests are power systems, power systems control and automation, Electrical Machines, power systems