

Realtime Safety Measures in Railways Using Embedded System

¹Lakshminarayana Chavala
ECE Department
Alpha College of Engineering
Chennai, India

²G. Tony Santhosh
ECE Department
Alpha College of Engineering
Chennai, India

Abstract— Nowadays Railway accidents quiet common in our daily routine life .So many innocent people lost their lives due to these accidents. For example, recently so many people dead in major fire accident happen in Tamilnadu express train in country India. We can stop like these disasters in future with present science and technology. This paper proposes a new system for preventing the accidents in railways using Sensor networks. It involves two parts of implementation. In the first part, the sensor nodes are used for collecting data such as temperature, concentration of smoke in air, intra and inter bogie temperatures automatically. These collected data are processed to monitor temperature and bogie temperature, if any mal detected exit door opens and water is pumped automatically in the compartment at the information is reached to locomotive engineer and the nearby station master. The second part implements the surveying system for the railway tracks which detects the cracks in the tracks using IR sensors and the derailment in train is detected using MEMS sensors. Hence the system performs both the data acquisition and the survey. The overall process is then controlled by the PIC micro controller which is 8 bit microcontroller and suits very well for the Data acquisition and the control system based application used largely in the industrial applications. In this project, PIC microcontroller gets the data's from sensor nodes, the survey sensors (Inclination using MEMS) manipulates and issues the control signals to the final control elements. Also, it uses GSM to send data's to the locomotive engineer. By implementing this project the Railway network will be safe and secure mode for transportation

Keywords—MEMS; GSM; IR Sensor; PIC Microcontroller

I. INTRODUCTION

The Railways is the chief mode of transport for the people for the people across various strata in the society. In such situation there is a need for ultimate security to be implemented across the railway network. Conventional railway networks lack the necessary infrastructure to respond swiftly to the emergencies such as fire accidents. Nowadays accidents have become part and parcel in our daily routine life not a single day passes without them. Whether they are road-accidents or they are train accidents or air crashes, they definitely occur every day in various parts of the world. Also other problem created when the continuous need in monitoring and maintaining the railway tracks to ensure to free from cracks and inclination. Depending on recent developments in railway system, high speed trains are being extensively used, and rail transportation is being increased.

Reasons for this increase are high speed, economical, environment friendly, safety and modern characteristics of railway systems. Depending on various factors, deformations may occur on the superstructure of railways. Determining these deformations on the time and taking precaution is very important for the safety of railway systems The proposed project introduces a real time survey and real time data acquisition and results are analyzed at the real time. If any mal detected at the system then the alerts are given at the real time and necessary safety measure will be provided. Smoke and fire sensors are implemented at specific points of the carriage to monitor the temperature of the carriage if any flaws deduced in the temperature then alert are provided to insure safety. The sudden change in temperature may cause mal like fire accidents. This can prevent by automatic opening of the doors of the compartments and pumping out order to avoid the fire accidents and if any mal detected exist door opens and water is pumped out automatically in the compartment. MEMS accelerometer is used to senses the axis of train.

II. SYSTEM BLOCK DIAGRAM

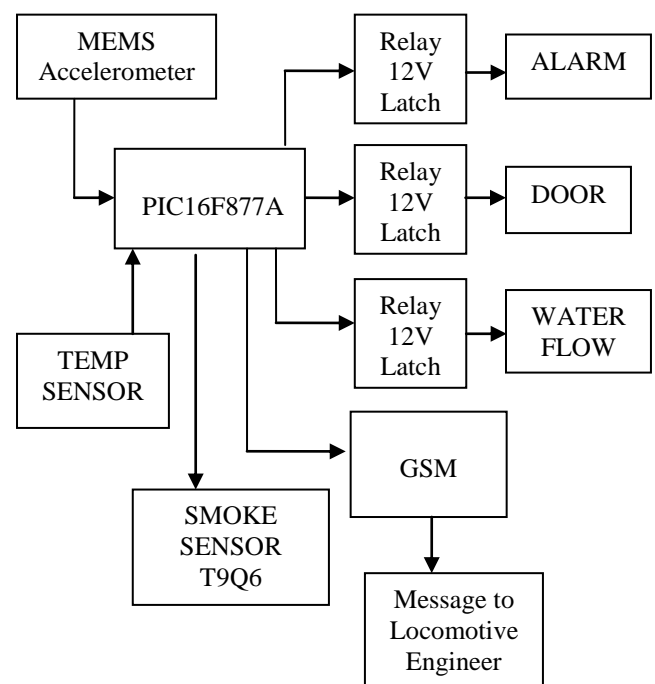

Fig. 1 Block Diagram of System

III. WORKING OF SYSTEM

These are the components used in this project. PIC microcontroller (PIC16F877A), MEMS Accelerometer, Temperature sensor (LM 235), Smoke Sensor (T9Q6), 12v relay switch and GSM. In this circuit we are using temperature sensor for to detect temperature level and smoke sensor for detecting CO_2 in the compartment. If the temperature is above the threshold level immediately the doors will open and water is pumped out automatically in the compartment and gives alarm. The message will be send to locomotive engineer through GSM automatically. The MEMS 3-axis accelerometer consists of a Mass at the centre of the sensor's chip, which is suspended by 4 Beams doped with Piezo-resistive material. When the sensor is subjected to acceleration in any direction, the movement of the Mass causes the 4 Beams to deform and so change the resistance in the piezo material. This enables the sensor to detect the acceleration motion.

IV. RESULTS AND DISCUSSIONS

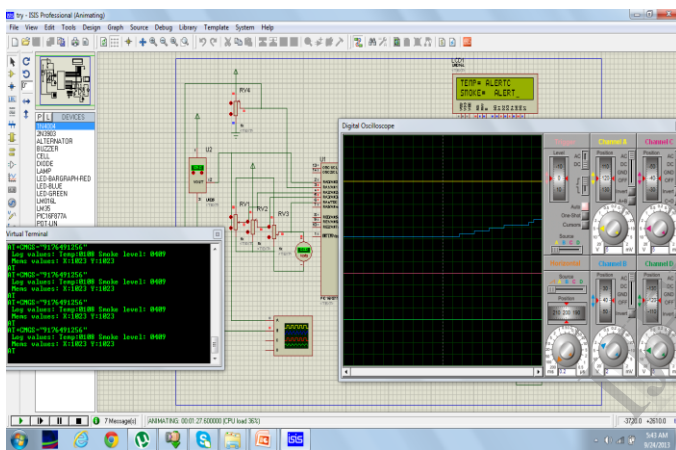

Fig. 2 Simulation of Safety Kit Module

The fig. 2 tells about the simulation of transmitter module, here all the sensors are connected to the PIC microcontroller and the readings of all the sensors are continuously monitored using the virtual terminal and if any mal detected relay opens and buzzer will be blown. At time of the buzzer blown it will also send the message to the locomotive engineer.

A. Smoke Sensor Reading

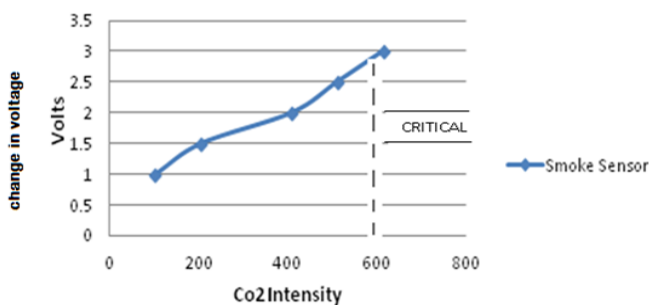

Fig. 3 Graph of Smoke Sensor

Here the fig .3 shows cut off region in the gas level CO_2 and Co levels are measured using MQ6. The atmospheric gas levels are measured and to restrict the gas level to 600 ppm.

B. Temperature Sensor Reading

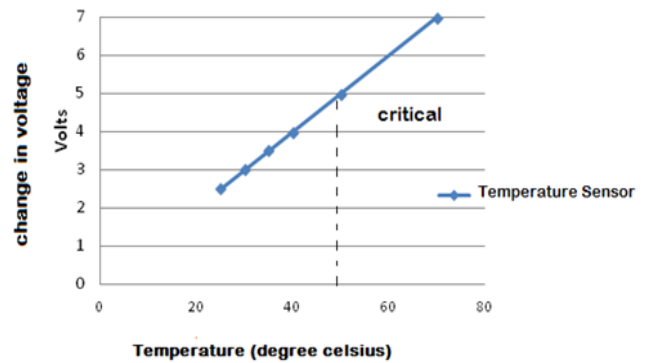

Fig. 4 Graph of Temperature Sensor

The temperature measurement is done to detect the fire accident inn the train, the measurements are made with LM35 which has the range from -50° to $+150^{\circ}C$. the sample are given to PIC 16f877 at the range of 500hz and the system is tested for cut off in $46^{\circ}C$.

C. MEMS Sensor Graphs

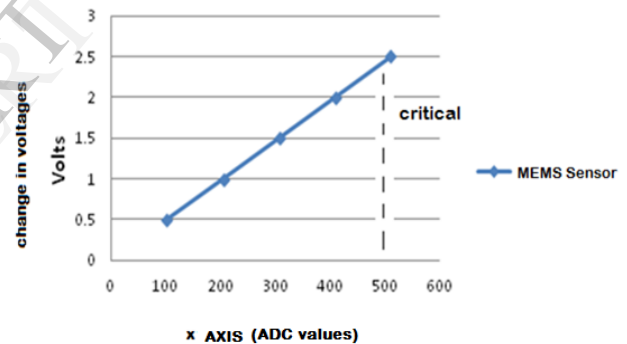

Fig. 5 Graph of MEMS Sensor at X Scale

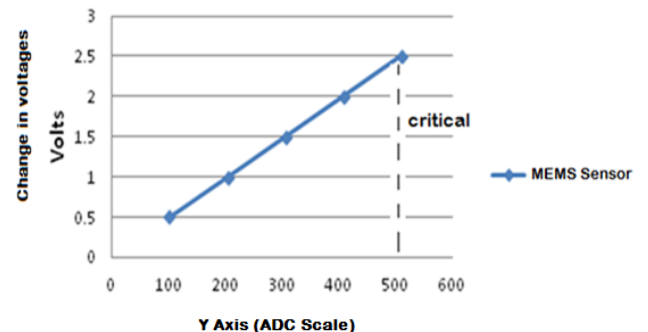

Fig. 6 Graph of MEMS Sensor at Y Scale

Here MEMS accclerometer used here to take the survey in the railway tracks to detect the derailment in the railway tracks and it also detects the overall balance of the train. A 3-axis accelerometer is used for the train which are placed perpendicular to the train wheels. If there is any derailment from that of the usual, then alert is given.

CONCLUSION

Thus the developed system ensures protection of accidents in railways using embedded systems. The sensor nodes are used for collecting data such as temperature, concentration of smoke in air, intra and inter bogie temperatures. These collected data are processed to monitor temperature and bogie temperature, if any mal detected exit door opens and water is pumped automatically in the compartment at the time information is reached to locomotive engineer and the nearby station master. This design gives a real time safety for railways.

REFERENCES

- [1] Burak Akpınar and Engin Gulal, "Multisensor Railway Track Geometry Survey System", IEEE Transaction on Instrumentation and Measurement, Vol.61, No.1, January 2012, pp 190-197.
- [2] Shubin Zheng, Xiaodong Chai, Xiaoxue An, Liming Li, "Railway Track Gauge Inspection Method Based on Computer Vision" IEEE International Conference on Mechatronics and Automation, August 5 - 8, 2012, pp1292-1296.
- [3] Jugen Wohlfeil, "Vision Based Rail Track and Switch recognition for Self Localization of Trains in Rail Network", IEEE Intelligent Vehicles Symposium, 5-9 June, 2011, pp 1025-1030.
- [4] Eui Jin Joung "A Study on Quality Improvement of Railway Software", International Conference on Control Automation and System, Oct 27-30, 2010, pp 767-770
- [5] Jacob Trehag, Peter Handel, "Onboard Estimation and Classification of Railroad Curvature", IEEE Transaction on Instrumentation and Measurement", Vol.59, No.3, March 2010, pp 653-660.
- [6] Boriss Misnevs, Alla Melikyan, "Model of assessment of the emergency danger on the railways", International Conference on Computer Modeling and Simulation, 2010, pp 28-31.

IJERT