

Remote Measurement and Control system for Greenhouse based on GSM-SMS

Vishal D Raut
M.Tech Student, DoT,
Shivaji University,
Kolhapur (M.S)
India

Dr.U.L.Bomble
Associate Professor,DoT,
Shivaji University,
Kolhapur(M.S)
India

Abstract

This paper explains the Remote Measurement & Control of Greenhouse based on GSM –SMS for controlling the Devices by SMS in greenhouse. The main purpose of this system conception is the remote control of the climatic parameters that influence the production in greenhouse. Several sensors and Control Devices are Used. These sensors provide relevant information that is used to control their different Devices Such as D.C Fan, Bulb, Water pump by SMS. The procedure used in our system provides the owner with a remote control avoiding the needed to perform the control actions on site. The developed system in this paper is ideally suited for agricultural greenhouses It is simple useful for farmers. Besides, most people use their cell phones to communicate and send messages. Thus, in our system, with a simple message, all farmers can control their greenhouses from a distance. They can know the status of their greenhouse climate (temperature, humidity) and can control the Devices.

Keywords: Sensors, Measurement, Microcontroller, GSM, Control, Zigbee ,Monitoring.

I. Introduction

The greenhouse industry is the fastest growing sector worldwide. The greenhouse separates the crop from the environment, This enables the production of crops that otherwise could not be produced at that specific location. The greenhouse enclosure permits the manipulation of the crop environment. This asset allows the farmer to steer the cultivation in a desirable direction. It leads to higher crop yield, prolonged production period, better quality, and less use of protective chemicals. The crop yield and quality can be influenced by operating the adjustable components of greenhouse. To fully exploit the enhanced possibilities

For crop and resource management in greenhouse, it is indispensable to adjust and control variables with a

remote controlling system via SMS by using the GSM - SMS. This is because it is almost difficult for human being to manipulate and be present every day near the system. Indeed, remote communication systems are a major component of the policy of modernization and technology transfer, due to the increasing development of mobile communications. The use of mobile phones or handsets has grown exponentially over the years [1]. Today, growth is coming from global expansion and services. A new surge of growth will come through new technology (Wireless) [2], Using GSM it is possible to control and monitor systems from a long Distance. The primary aim of this paper is to propose the concept of Development of a Low-Cost GSM SMS-Based Remote Measurement and Control system for Greenhouse using the combination of a ARM Controller [3] and a GSM communications module & Zigbee linked by a serial communications port. Using this various Parameter values could be efficiently understands from the remote location and whenever it crosses the set limit, the ARM processor will send an SMS to a concerned authority(s) mobile phone. The concerned authority(s) can control the system through the mobile phone by sending Message to the System. The benefits of this paper are:

- Flexibility / modularity in control
- Extremely low cost device adapted for different applications.
- Scalable, Robust and Reliable.
- Efficient and cheap means of communication by use of SMS.
- Ideal for monitoring and control critical plant on unmanned sites.

II. FUNCTIONAL BLOCK DIAGRAM AND DESCRIPTION

The Functional Block diagram of the entire system is as shown in the Figure 1

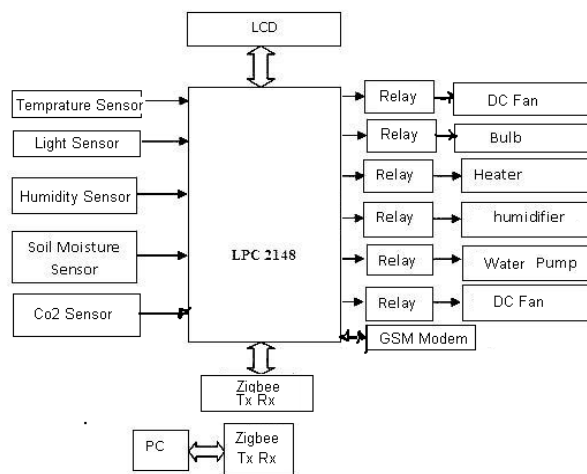

Figure 1. Functional Block Diagram

All the major subsystem blocks are shown with their interconnections to each module. The block diagram consists of Temperature Sensor, Humidity Sensor, Soil moisture, Light Sensor, CO2 Sensor, ARM LPC2148 Processor, GSM MODEM (SIM300), MAX232 Level converter, Controlling devices, Relay set and Personal computer. In this application, the system was set up to monitor and control the relative Devices and ensures that it was within safe operating

Limits. The detailed descriptions of the blocks used in the system are explained

A. ARM 7 LPC2148

The LPC2148 is an ARM 7 high-performance 32-bit RISC Microcontroller with Thumb extensions 512KB on-chip Flash ROM with In-System Programming (ISP) and In-Application Programming (IAP), 32KB RAM, Vectored Interrupt Controller, Two 10bit ADCs with 14 channels, USB 2.0 Full Speed Device Controller, Two UARTs, one with full modem interface. Two I2C serial interfaces, Two SPI serial interfaces Two 32-bit timers, Watchdog Timer, PWM unit, Real Time Clock with optional battery backup, Brown out detect circuit General purpose I/O pins. CPU clock up to 60 MHz, On-chip crystal oscillator and On-chip PLL. Due to their tiny size and low power consumption, LPC2148 are ideal for applications where miniaturization is a key requirement, such as access control and point-of-sale. Serial communications interfaces ranging from a USB 2.0 Full-speed device, multiple UARTs, SPI, SSP to I2C-bus and on-chip SRAM of 8 kB up to 40 kB, make these devices very well suited for communication gateways and protocol converters, soft modems, voice recognition and low end imaging, providing both large buffer size and high

processing power. Various 32-bit timers, single or dual 10-bit ADC(s), 10-bit

DAC, PWM channels and 45 fast GPIO lines with up to nine edge or level sensitive external interrupt pins make these microcontrollers suitable for control systems. [7][8].

B. Sensors

Temperature Sensor

The LM35 series are precision integrated-circuit temperature sensors, whose output voltage is linearly proportional to the Celsius (Centigrade) temperature. The LM35 thus has an advantage over linear temperature sensors, as the user is not required to subtract a large constant voltage from its output to obtain convenient centigrade scaling. Features are as follows. [4]

1. Calibrated directly in ° Celsius (Centigrade)
2. Linear + 10.0 mV/°C scale factor
3. 0.5°C accuracy guaranteeable (at +25°C)
4. Rated for full -55° to +150°C range
5. Suitable for remote applications
6. Low cost due to wafer-level trimming
7. Operates from 4 to 30 volts

Humidity Sensor (SY-HS-220)

These modules convert relative humidity to the output voltage. Humidity Sensor is designed to operate on DC 5 V, 0-60° c, 30-90° c RH, output voltage is DC 1.980 mv ± at 25 °c 60% RH. [5]

Soil Moisture Sensor:

This basic cheap soil moisture sensor consists of two probes (the metal rods or Ordinary galvanized nails) held apart at a fixed distance by some insulating material. They are used to sense soil moisture. Two pieces of wire, each 2' long, and strip 1/2" off the ends. One end of each wire is wrapped around the head of each nail. Cover the wire-nail connection with a generous amount of solder. By measuring the resistance between the two nails stuck in the soil, water requirement of soil can be determined. More the water in the soil more is the conductivity. It uses the two probes to pass current through the soil and to measure the resistance to get the moisture level. More water makes the soil more conductive (less resistance), while for dry soil conductivity is poor (more resistance).

LDR- Light Dependent Resistor [6]

Two cadmium sulphide (cds) photoconductive cells with spectral responses similar to that of the human eye. The cell resistance falls with increasing light intensity. Applications include smoke detection, automatic lighting control, and batch counting and burglar alarm systems.

C. Controlling Section

1. If temperature > Set temperature then turn ON the DC FAN.
2. If temperature < Set temperature then turn ON the Heater
3. If light intensity < Set light intensity then turn ON the Bulb
4. If humidity <Set humidity then turn ON the Humidifier
5. If soil moisture < Set soil moisture then turn ON the Pump
6. If co2>Set Co2 then turn on DC fan.

D. GSM MODEM

A GSM modem is a specialized type of modem, which accepts a SIM card, and operates over a subscription to a mobile operator, just like a mobile phone. From the mobile operator perspective, a GSM modem looks just like a mobile phone. A GSM modem can be a dedicated modem device with a serial, USB or Bluetooth connection, or it may be a mobile phone that provides GSM modem capabilities. Here SIM 300 Modem is used.

E. Personal Computer

A Personal computer is a programmable machine that receives input, stores and manipulates data, and provides output in a useful format. A personal computer may be a desktop computer, a laptop. The data logging is achieved continuously by the ARM7 LPC2148 processor to the personal Computer. This data is received by the software running on the PC and continuously updates a database by using Visual Basic and also we can generate graphs automatically.

F. ZigBee

It is one of the latest and upcoming technologies in the field WSN. ZigBee is low cost, low power, wireless network standard. Low power usage allows longer life with smaller battery.ZigBee has been developed to meet the growing demand for capable wireless networking between numerous low power devices. So it is widely deployed for wireless monitoring and control applications [9].

III. HARDWARE IMPLEMENTATION AND DESCRIPTION

The circuit diagram of the entire system is shown in Figure 2. Various Parameters are taken such as Temperature , Humidity ,Light will sense gives a voltage output corresponding to values. This signal is taken into LPC2148 processor through the analog input channel for comparison. This signal is digitized using the inbuilt 10-bit ADC of the LPC2148 processor and compare the data with Predefined data for any status changes or value crossing the limit. Then System will send the message to concerned authority(s) by sending an SMS through GSM MODEM to his/her Mobile phone and Then authorized person sends message to the system then microcontroller switches the ON/OFF. The authority(s) can also monitor the status of the Controlled Devices. The measured values are displayed in personal computer for further analysis of graphs.

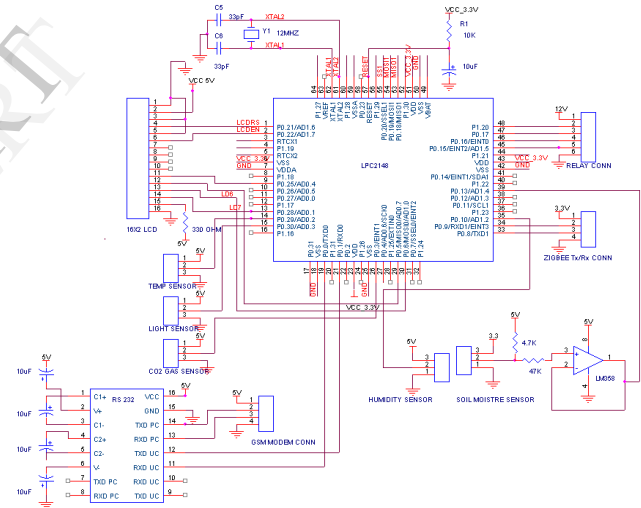

Figure2 The circuit diagram of the entire system

IV. SOFTWARE DEVELOPMENT

The software for the system is developed in Embedded C and Visual Basic. The flowcharts depicting the measurement and the control of Green house shown in Fig.3&4

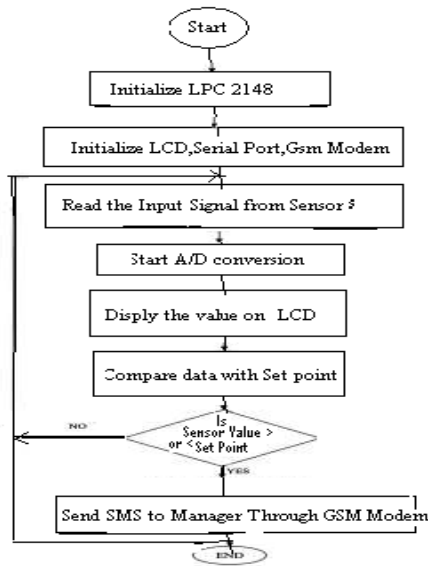

Figure 3. The flowcharts depicting the measurement

In Figure 5 shows the device status, current data and high limit values of sensors.

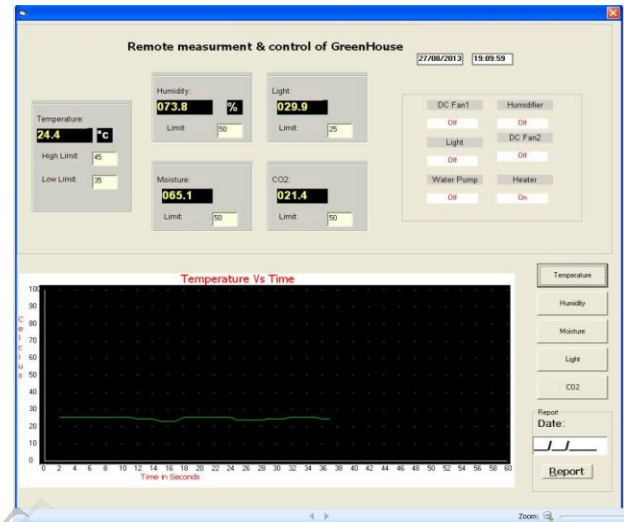

Figure 5 The results obtained by using the proposed system which are final outputs.

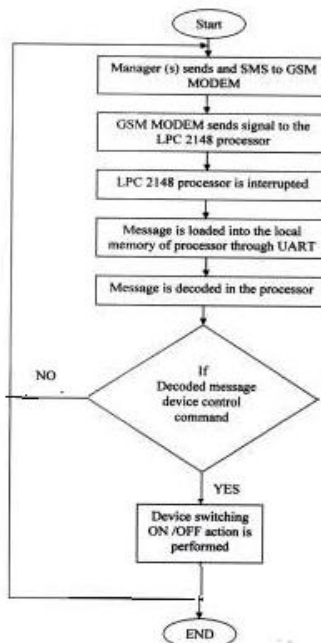

Figure 4 The flowcharts depicting the control of Green house

V. RESULTS

The results obtained by using the proposed system are

VI. CONCLUSION

The system has provided a low cost, remotely monitored and controlled solution for Greenhouse introduced. The use of a ARM Processor, GSM module, Sensors and different Controlling devices provide exciting possibilities. However as far as the Greenhouse applications are concerned this can be viewed as a low cost, customized Remote Measurement and Control system .The approach discussed in the paper is novel and has achieved the target to control Greenhouse remotely using the GSM SMS-based system satisfying user needs and requirements. GSM technology capable solution has proved to be controlled remotely. Hence we can conclude that the required goals and objectives of the system have been achieved.

References

[1] Ken Wieland, "Spreading the Word" Telecommunications Magazine International Edition October 2004, Issue Highlights.
 [2] Ciubotaru-Petrescu B, Chiciudean D, Cioarga R, Stanescu D, "Wireless Solutions for Telemetry in Civil Equipment and Infrastructure Monitoring", 3rd Romanian-Hungarian Joint Symposium on Applied Computational Intelligence (SACI) May 25-26, 2006

- [3] Trever Martin, The Insiders Guide to the Philips ARM7 Based Microcontroller, C Eng MIEE, Feb 2005
- [4]National Semiconductor Corporation, LM35 datasheet, precision centigrade Temperature sensors, Atmel data book
- [5] SY-SH-220 datasheet
- [6]http://www.biltek.tubitak.gov.tr/gelisim/elektronik/dosyalar/40/LDR_NSL19_M51.pdf
- [7] Trever Martin, The Insiders Guide to the Philips ARM7 Based Microcontroller, CEng MIEE, Feb 2005
- [8]http://www.nxp.com/documentts/data_sheet/LPC2148.pdf
- [9] Dr.S.S.Riaz Ahamed.Role of Zigbee technology in future data communication system. Journal of Theoretical and Applied Information Technology, Vol.5 No. 2, pp 129-135, 2005
- [10] Puneet Gupta, SMS: How, what and where, Wireless Developer Network.

IJERT