

Shunt Active Power Filter for the Enhancement of Power Quality using Fuzzy Logic Controller

M.Deepthi

Dept. of Electrical Engg

*Shri Vishnu Engg.College for Women
Bhimavaram, Andhra Pradesh, India*

K.P.Swaroop

Dept. of Electrical Engg

*Shri Vishnu Engg.College for Women
Bhimavaram, Andhra Pradesh, India*

Abstract

In recent years, the applications of power electronics have grown tremendously. These power electronic systems offer highly nonlinear characteristics. To overcome those non linearities active power filters are preferred. This paper presents and compares the performance of two controllers namely Fuzzy Logic and Proportional Integral (PI) applied to a voltage source inverter / converter which operates as an active power filter. The active power filter is operated to compensate harmonics generated by the non-linear load .This work is done to make an accurate comparison of the performance of fuzzy logic controller and classical control technique such as PI controller in compensating harmonics in the ac mains current. Fuzzy control rule design is based on the general dynamic behavior of the process. A novel control method is implemented for suppressing the harmonics. The compensation process is instantaneous, which is achieved without employing any complicated control logic. The control scheme is based on sensing line currents only; an approach different from convention ones, which are based on sensing harmonics of the nonlinear load. In the control scheme a hysteresis controller based on current control is employed to generate switching signals to the PWM converter.

Examples of such applications that are widely used are adjustable-speed motor drives, uninterruptible power supplies (UPSs), computers and their peripherals, consumer electronics appliances (TV sets for example), to name a few. Those power electronic devices offer economical and reliable solutions to control and manage the use of electric energy effectively. However, most of the power electronic circuits, exhibit nonlinear operational characteristics, which introduce contamination to voltage and current waveforms at the point of common coupling in case of industrial loads.

An increase in such nonlinearity results in various undesirable features such as: increased harmonics in current from AC mains, low system efficiency and a poor power factor, cause disturbance to other consumers, interference in nearby communication networks, unexplained computer network failures, premature motor burnouts, e t c . Therefore thermal trip devices(circuit breakers and fuses) could activate to remove the loads on that path from the lines. These are only a few of the damages that power quality problems may bring into home and industrial installations. This may seem like minor quality problems but may bring whole factories to a standstill [1].

Recently, shunt active power filters based on current controlled PWM converters have been widely found and identified as an effective solution [2].

However, most of their working is based on sensing harmonics generated by the nonlinear load, which require complex control. A scheme had been proposed by Duke and Round [3] in which, the required compensating current is determined by using a simple synthetic sinusoid generation

The remainder of the paper is structured as follows: in section II compensation principle is discussed, section III describes the proposed fuzzy logic scheme, in section IV PWM switching law is discussed, section V and VI presents the simulation results and conclusion respectively.

1.INTRODUCTION

Modern semiconductor switching devices find a wide range of applications in distribution networks, particularly in domestic and industrial loads which are being utilized quite often. technique which is based on sensing the load current. A scheme which is simple and easy to implement is proposed by modifying the above scheme and it works by sensing line currents only [2,4].

In the recent years, Fuzzy Logic Controllers (FLCs) have generated a good deal of interest in certain applications [5]. The advantages of FLCs over conventional controllers are that they do not need an accurate mathematical model, they can handle non-linearity, they can work with imprecise inputs, and they are more robust than conventional nonlinear controllers [6].

2.COMPENSATION PRINCIPLE

The active power filter is controlled to draw/supply the compensating current i_f from/to the utility to cancel out the current harmonics on AC side thereby making the source current in phase with source voltage thus improving the power

factor. Fig .1 shows the basic compensation principle of an active power filter.

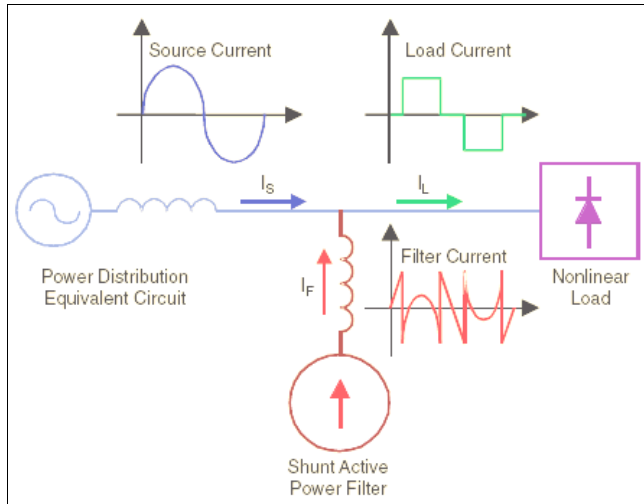

Fig. 1: Basic Compensation Principle

2.1. Significance of DC Capacitor

The DC capacitor has two main purposes: During steady state period it maintains a DC voltage with small ripple and in the transient period it behaves as an energy storage element to supply the real power difference between load and source.

When the load condition changes there will be a disturbance in the real power balance between the load and the source. This difference in real power is to be compensated by the DC capacitor and hence the DC capacitor voltage changes away from the reference voltage. For the satisfactory operation of the active filter, the peak value of the reference source current must be adjusted to proportionally change the real power drawn from the source. This real power charged/discharged by the capacitor compensates the real power consumed by the load. If the DC capacitor voltage is recovered and reaches the reference voltage then, the real power supplied by the source is supposed to be equal to that consumed by the load again.

It is in this way that, by regulating the average voltage of the DC capacitor the reference source current can be obtained.

2.2. Estimation of Reference Source Current

Ideal compensation demands the mains current to be sinusoidal and in phase with the source voltage, irrespective of the nature of load current. After compensation, the desired source currents will be of the form

$$\begin{aligned} i_{sa}^* &= I_{sp} \sin \omega t \\ i_{sb}^* &= I_{sp} \sin(\omega t - 120) \\ i_{sc}^* &= I_{sp} \sin(\omega t + 120) \end{aligned} \quad \dots\dots (1)$$

Where $I_{sp} = I_1 \cos \phi_1 + I_{SL}$ is the amplitude of the desired source current, while the phase angle can be obtained from the source voltages by multiplying with the unit vectors of respective voltages.

From Fig. 1, instantaneous currents can be written as

$$i_s(t) = i_L(t) - i_c(t) \quad \dots\dots (2)$$

Where, $i_s(t)$, $i_c(t)$, $i_L(t)$ are instantaneous source, filter and load currents respectively. Source voltage is given by

$$v_s(t) = V_m \sin \omega t \quad \dots\dots(3)$$

Where, $v_s(t)$, V_m are instantaneous and peak value of source voltages respectively. If a nonlinear load is applied, the load current can be represented as

$$i_L(t) = \sum_{n=1}^{\infty} I_n \sin(n\omega t + \phi_n) \quad \dots\dots(4)$$

$$i_L(t) = I_1 \sin(\omega t + \phi_1) + \sum_{n=2}^{\infty} I_n \sin(n\omega t + \phi_n)$$

The instantaneous load power can be given as

$$\begin{aligned} p_L(t) &= v_s(t) * i_L(t) \\ p_L(t) &= p_f(t) + p_r(t) + p_h(t) \end{aligned} \quad \dots\dots(5)$$

The real (fundamental) power drawn by the load is given by

$$p_f(t) = V_m I_1 \sin^2 \omega t * \cos \phi_1 = v_s(t) * i_s(t) \quad \dots\dots(6)$$

From (6), the source current supplied by the source, after compensation is

$$i_s(t) = p_f(t) / v_s(t) = I_1 \cos \phi_1 \sin \omega t = I_{sm} \sin \omega t$$

Where $I_{sm} = I_1 \cos \phi_1$. There are also some switching losses in the PWM converter, and hence the utility must supply a small overhead for the capacitor leakage and converter switching losses in addition to the real power of the load. The total peak current supplied by the source is therefore

$$I_{sp} = I_{sm} + I_{SL} \quad \dots\dots(7)$$

Here we are considering the dc capacitor voltage for generation of error signal when compared with a reference value and actual source current is compared with reference source current in hysteresis controller to generate the switching signals. So there is no need of calculations for the small overhead. If the active filter provides the total harmonic power, then $i_s(t)$ will be in phase with the utility voltage and purely sinusoidal. At this instant, the active filter must be in a position to provide the following compensating current

$$i_c(t) = i_L(t) - i_s(t)$$

Hence, for accurate and instantaneous compensation of harmonic power it is necessary to estimate $i_s(t)$ which is the fundamental component of the load current as the reference current.

Hence, the waveform and phases of the source currents are known (from Eqn. (1)), and only their magnitudes are to be determined. This peak value of the reference current has been estimated by regulating the voltage of the DC capacitor of the PWM converter [6]. The capacitor voltage is compared with a reference value and the error is processed in a fuzzy logic controller. The output of the fuzzy controller is considered as the amplitude of the desired source current, and the reference currents are estimated by multiplying this peak value with the unit sine vectors in phase with the source voltages.

2.3. Estimation of Reference Current Templates

Using fuzzy logic controller, the peak value of reference current I_{max} is estimated by controlling the DC capacitor voltage in the closed loop. The output of the fuzzy control algorithm is the change in reference current $\delta I_{max}(n)$. The peak reference current at nth sampling time $I_{max}(n)$ is determined by adding the previous reference current $I_{max}(n-1)$ to the calculated change in reference current

$$I_{max}(n) = I_{max}(n-1) + \delta I_{max}(n) \dots (8)$$

This is an integrating effect which improves the steady state error in classical control theory.

3. PROPOSED FUZZY CONTROL SCHEME

For implementing the control algorithm of a shunt active power filter in closed loop, the DC capacitor voltage is sensed and compared with a reference value.

The obtained error

$$e(n) = V_{dc,ref}(n) - V_{dc,act}(n)$$

and change in error

$$ce(n) = e(n) - e(n-1)$$

at the nth sampling instant are taken as inputs for the fuzzy processing. The control scheme is shown in Fig. 3. After a limit, the output of the fuzzy controller is considered as the amplitude of the reference current I_{max} . This current I_{max} takes care of the losses in the system and the active power demand of load. By comparing the actual source currents (i_{sa} , i_{sb} , and i_{sc}) with the reference current templates (i_{sa}^* , i_{sb}^* , and i_{sc}^*) in the hysteresis current controller, the switching signals for the PWM converter are obtained [6]. After proper amplification and isolation, the switching signals so obtained, are given to switches of the PWM converter.

3.1. Basic Fuzzy Algorithm

The internal structure of the fuzzy controller is shown in Fig. 4. The error 'e' and change in error 'ce' are the real world numerical variables of the system. The following seven fuzzy levels or sets: NB (negative big), NM (negative medium), NS (negative small), ZE (zero), PS (positive small), PM (positive medium), and PB (positive big) are chosen to convert these numerical variables to linguistic variables as shown in Fig.5 .

The characterization of fuzzy controller is as follows:

- (i) Seven fuzzy sets for each input and output.
- (ii) Triangular membership functions for simplicity.
- (iii) Fuzzification using continuous universe of discourse.
- (iv) Implication using Mamdani's 'min' operator.
- (v) Defuzzification using the 'centroid' method.

3.2. Rule Base

The elements of the rule base table are determined based on the theory that in the transient state, large errors need coarse control, which require coarse input/output variables and in the steady state, small errors need fine control, which require fine input/output variables. Based on this the elements of the rule

table are obtained as shown in Table.1, with 'e' & 'ce' as inputs.

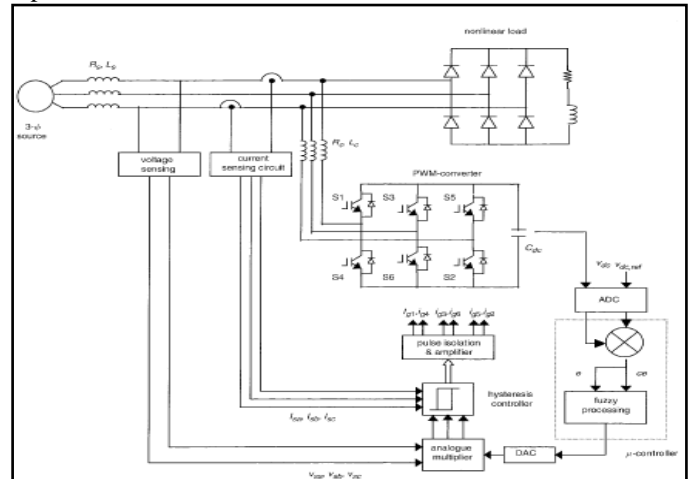

Fig.2: Schematic Diagram of Closed Loop Fuzzy Logic Controlled Shunt Active Power Filter

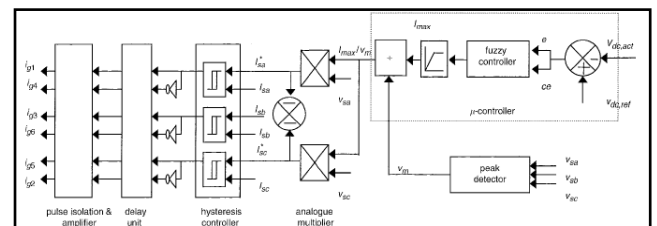

Fig.3: Fuzzy Control scheme

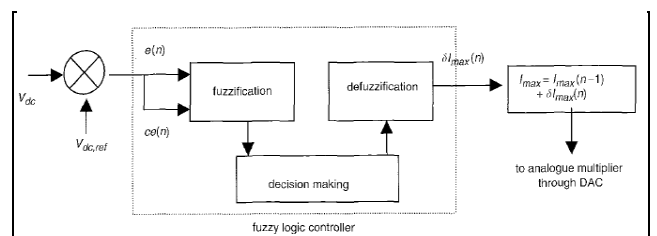

Fig. 4: Internal Structure of Fuzzy controller

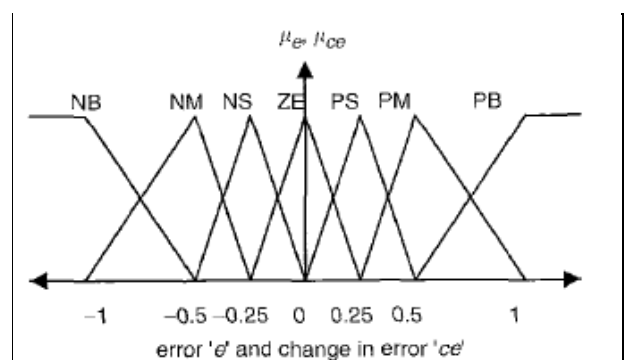

Fig. 5: Input Normalized Membership Function

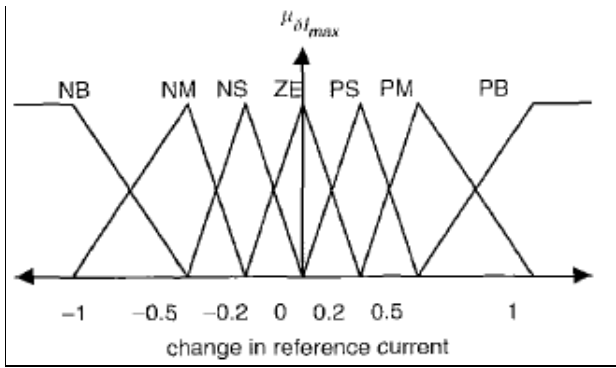

Fig. 6: Output Normalized Membership Function

Table .1 Control Rule Table

ce	NB	NM	NS	ZE	PS	PM	PB
e	NB	NB	NB	NB	NM	NS	ZE
NB	NB	NB	NB	NB	NM	NS	ZE
NM	NB	NB	NB	NM	NS	ZE	PS
NS	NB	NB	NM	NS	ZE	PS	PM
ZE	NB	NM	NS	ZE	PS	PM	PB
PS	NM	NS	ZE	PS	PM	PB	PB
PM	NS	ZE	PS	PM	PB	PB	PB
PB	ZE	PS	PM	PB	PB	PB	PB

4.PWM SWITCHING LAW

The hysteresis current controller decides the switching signals for the switching devices of the PWM converter. The switching signals are obtained as: If $i_{si} > i_{si}^* + hb$, the upper switch of the i^{th} leg is ON and lower switch is OFF. Consequently if $i_{si} < i_{si}^* - hb$, the upper switch of the i^{th} leg is OFF and lower switch is ON, where 'hb' is the hysteresis band around the reference current.

5.SIMULATION RESULTS

System Parameters: Following are the system parameters taken into consideration for the study of APF using both PI and Fuzzy controllers. $V_s = 100$ V(Peak), $f = 50$ Hz, $R_s = 0.1 \Omega$, $L_s = 0.15$ mH, $R_f = 0.1 \Omega$, $L_f = 0.66$ mH, $R_l = 6.7 \Omega$; $L_l = 20$ mH, $C_{dc} = 2000\mu F$, $V_{dref} = 220$ V. In case of PI controller the gains chosen are $k_p = 0.2$ and $k_i = 9.32$. Responses are as shown in Fig. 7 & 8.

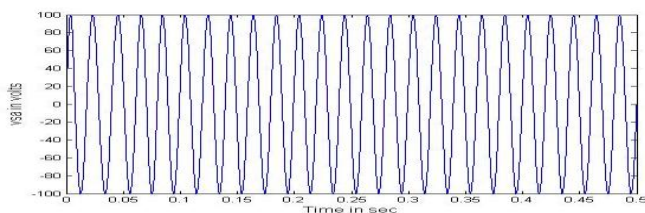

Fig. 7(a) Source voltage

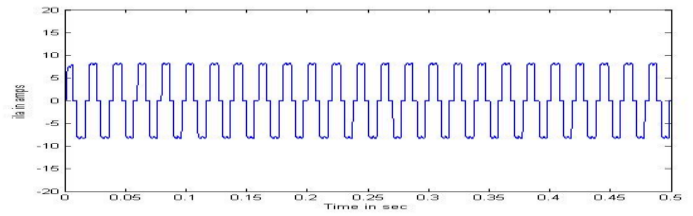

Fig. 7(b) Load current

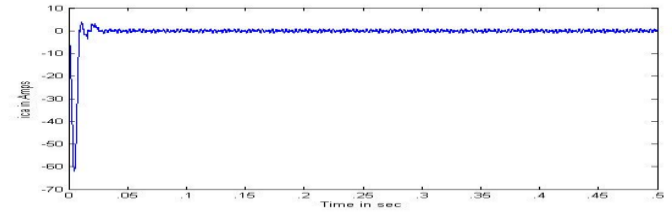

Fig. 7(c) Compensating current

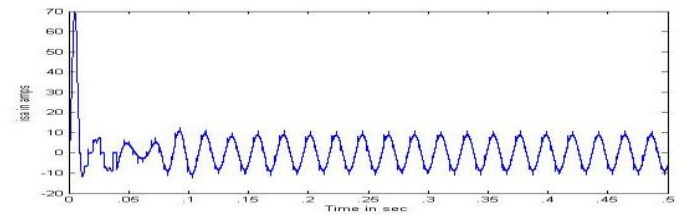

Fig. 7(d) Source current

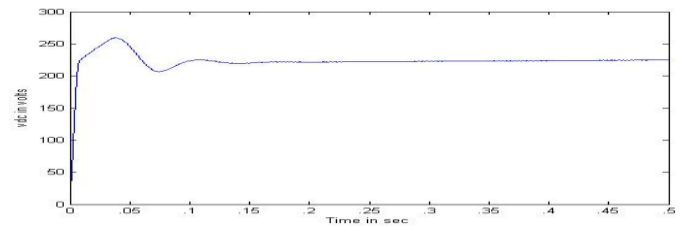

Fig. 7(e) DC capacitor voltage

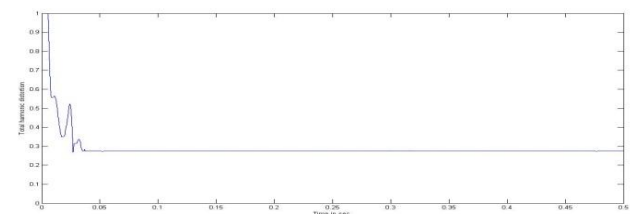

Fig. 7(f) Total Harmonic Distortion

Fig. 7 Performance of APF using PI Controller

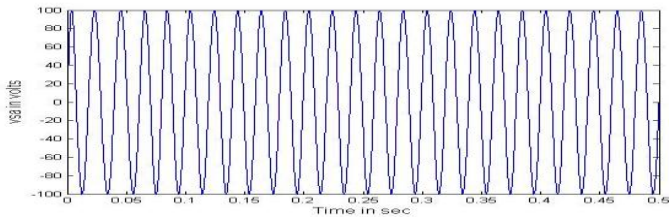

Fig. 8(a) Source voltage

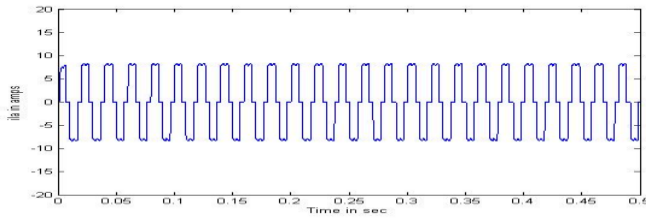

Fig. 8(b) Load current

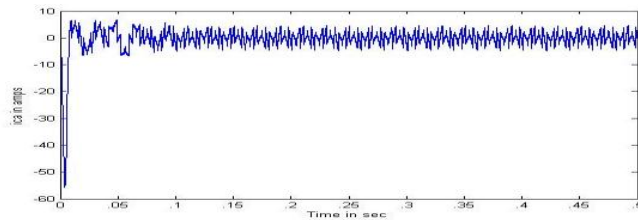

Fig. 8(c) Compensating current

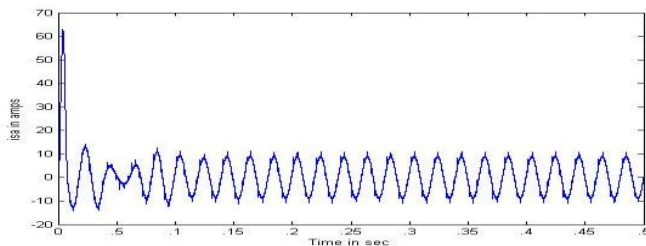

Fig. 8(d) Source current

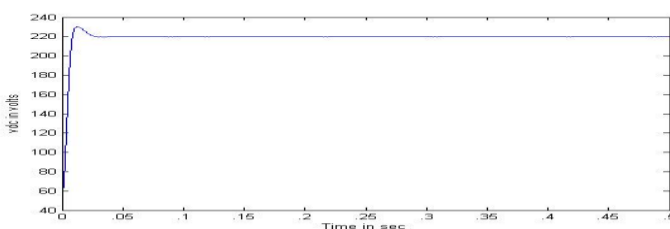

Fig. 8(e) DC capacitor voltage

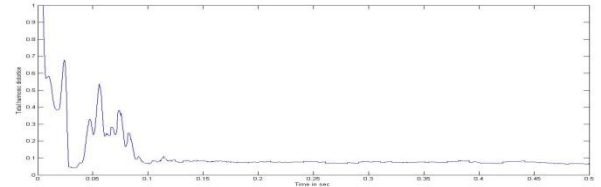

Fig. 8(f) Total Harmonic Distortion

Fig. 8 Performance of APF using Fuzzy Logic Controller

6.CONCLUSION

The performance of a fuzzy logic controlled and PI controlled harmonic compensator has been studied. The performance of the system with fuzzy controller has been observed as superior in providing harmonic compensation. From figures 7(c) & 8(c) it can be observed that better compensating currents are introduced into the source current with the use of fuzzy controller. From figures 7(d) & 8(d) it can be seen that the fuzzy controller could produce source current more closer to sinusoidal nature thus making it in phase with source voltage, thereby improving power factor of the system. The settling time for the DC capacitor voltage with fuzzy controller is less when compared to the capacitor voltage with PI controller. Also the number of oscillations are less in case of fuzzy controller which are represented in figures 7(e) & 8(e). Hence fuzzy controller is proved to be superior than PI controller in consideration with total harmonic distortion of the system as shown in figures 7(f) & 8(f).

7.REFERENCES

- [1] Hugh Rudnick, Juan Dixon and Luis Morán, "Active power filters as a solution to power quality problems in distribution networks" IEEE power & energy magazine, pp. 32-40, September/October 2003.
- [2] Singh, B., Chandra, A., and Al-Haddad, K., "computer aided modelling and simulation of active power filters", Electr. Mach, Power sys., pp.1227-1241, 1999.
- [3] DUKE, R.M., and Round, S.D., "The steady state performance of controlled current active filter". *IEEE Trans. Power Electron*, pp. 140-146, 1993.
- [4] Chatterjee, K, Fernandes, H.G., And Dubey, G.K.: "An instantaneous reactive volt-ampere compensator and harmonic suppressor". *IEEE Trans., Power Electron.*, pp.381- 392., 1999.
- [5] V. S. C. Raviraj and P. C. Sen, "Comparative Study of Proportional-Integral, Sliding Mode, and Fuzzy Logic Controllers for Power Converters", *IEEE Transactions On Industry Applications*, Vol. 33, No.2, March/April 1997.
- [6] S. K. Jain, P. Agrawal, and H. O. Gupta, "Fuzzy logic controlled shunt active power Filter for power quality improvement," *Proceedings of Institute of Electrical Engineers, Electrical Power Applications*, vol. 149, no. 5, 2002.