

System Stability Using FACTS

Sandeep Kaur¹, Apoorva Kanthwal², Raja Singh Khela³

¹ Asst. Professor, Department Of Electrical & Electronics Engineering,
Chandigarh University, Gharuan (Mohali), Punjab

² Asst. Professor, Department Of Electrical & Electronics Engineering,
Chandigarh University, Gharuan (Mohali), Punjab

³ Director, Quest College Of Engineering & Technology,
Jhanjeri (Mohali), Punjab

Abstract— In the field of instrumentation, simulations of various controllers are done by using various softwares such as MATLAB/Simulink & LabVIEW etc. Due to fast developments in technology, the choice of hardware and software should be considered carefully along with cost. It is a fact that the cost of designing new instrumentation can be decreased significantly if displays are modeled in software rather than in hardware components. A number of interactive computer delivered simulations, control, scientific visualizations software solutions are available which uses diverse software such as LabVIEW, MATLAB/SIMULINK etc. The main aim is to model multimachine system with STATCOM & UPFC controllers in Simulink/MATLAB which is very much closer to the actual physical system and analyze their response using MATLAB/Simulink. The simulated STATCOM & UPFC shows how the oscillations are damped out with STATCOM & UPFC controller. Change in the value of various parameters of the STATCOM & UPFC controller affects the stability of the system

Keywords— Statcom, Matlab, UPFC & Simulink.

I. INTRODUCTION

Stability of power system has been a major concern in system operation. This arises from the fact that in steady state, the angular speed of all the generators must remain the same anywhere in the system. The stability of a system determines whether the system can settle down to the original or close to the steady state after the transients disappear. In general, power system stability is the ability to respond to a disturbance from its normal operation by returning to a condition where the operation is again normal.

Power system stability may be broadly defined as that property of a power system that enables it to remain in a state of operating equilibrium under normal operating conditions and to regain an acceptable state of equilibrium after being subjected to a disturbance.

Stability of a power system is divided into three broad classes namely

- Steady state stability
- Transient stability
- Dynamic stability

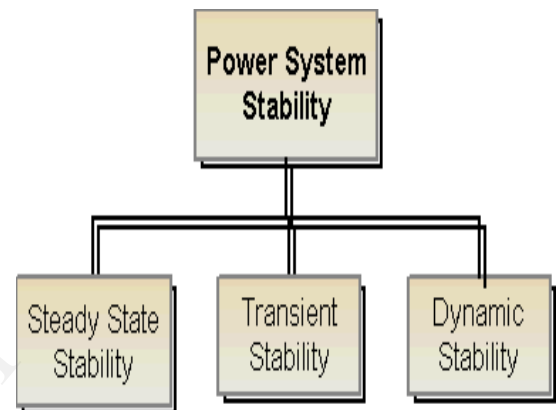

Figure 1. Power system Stability diagram

II. TRANSIENT STABILITY IMPROVEMENT CONTROLLER

The loss of transient stability in a power system is due to overloading of some of the lines (or due to severe line faults), as a consequence of tripping off of the other lines after faults or heavy loss of loads. By means of rapid and flexible control over the ac transmission parameters and network topology, FACTS technology can facilitate power control, enhance the power transfer capacity, decrease the line losses, increase power system damping and improve the stability and security of the power system.

Flexible AC Transmission Systems (FACTS) is alternating current transmission systems incorporating power electronics based and other static controllers with an aim to build flexibility in the system in order to enhance controllability and increase power transfer capability.

By providing added flexibility, FACTS controllers can enable a line to carry power closer to its thermal rating. FACTS technology refers to device that enables flexible electrical power system operation i.e. controlled active and reactive power flow redirection in transmission paths. FACTS device offers continuous control of power flow or voltage, against daily load changes or even change in network topologies.

III. FACTS CONTROLLERS (STATCOM & UPFC)

FACTS Controller is a power electronic based system and other static equipment that provide control of one or more AC transmission system parameters. The term FACTS controllers describes power electronic based circuit configuration applied in ac transmission systems. FACTS represent flexible ac transmission system, with the term 'flexible' implying the controllability of voltage and/or current.

Controllable Parameters for FACTS Controllers

There are few basic points that are to be considered regarding the possibilities of power flow control. These are:

- Control of the line impedance X can provide a powerful means of current control.
- When the angle is not large, which is often the case, control of X or the angle substantially provides the control of active power.
- Control of angle which in turns control the driving voltage, provides powerful means of controlling the current voltage and hence active power flow when the angle is not large.
- Injecting a voltage in series with line, and perpendicular to the current flow, can increase or decrease the magnitude of the current flow. Since the current flow lags the driving voltage by 90 degree, this means injection of reactive power in series, can provide a powerful means of controlling the line current, and hence the active power when the angle is not large.
- Injecting a voltage in series with line and with any phase angle with respect to the driving voltage can control the magnitude and the phase of the current. This means that injecting the voltage phasor with variable phase angle can provide powerful means of precisely controlling the active and reactive power flow; this requires the injection of both active and reactive power in series.
- When the angle is not large, controlling magnitude of one or the other line voltages can be a very cost effective means for the control of reactive power flow through the interconnection.

IV. STATIC SYNCHRONOUS COMPENSATOR (PHASOR TYPE)

The Static Synchronous Compensator (STATCOM) is a shunt device of the Flexible AC Transmission Systems (FACTS) family using power electronics to control power flow and improve transient stability on power grids . The STATCOM regulates voltage at its terminal by controlling the amount of reactive power injected into or absorbed from the power system. When system voltage is low, the STATCOM generates reactive power (STATCOM capacitive). When system voltage is high, it absorbs reactive power (STATCOM inductive).

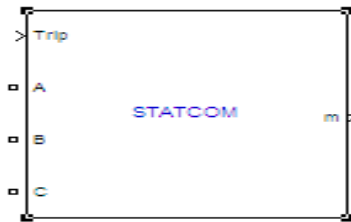

Figure 2.Statcom block

The variation of reactive power is performed by means of a Voltage-Sourced Converter (VSC) connected on the secondary side of a coupling transformer. The VSC uses forced-commutated power electronic devices (GTOs, IGBTs or IGCTs) to synthesize a voltage V_2 from a DC voltage source. The principle of operation of the STATCOM is explained on the figure 3.2 showing the active and reactive power transfer between a source V_1 and a source V_2 . In this figure, V_1 represents the system voltage to be controlled and V_2 is the voltage generated by the VSC.

V. SYSTEM MODELLING AND SIMULATION

STATCOM & UPFC controller has been envisaged to be used for several power-system performance enhancements, namely, the improvement in the system stability, damping of power oscillations, prevention of voltage collapse, dynamic voltage control etc.

Multi-Machine System Modeling

The popular Western System Coordinated Council (WSCC) 3-machines 9-bus practical power system with loads assumed to be represented by constant impedance model. WSCC system is widely used and found very frequently in the relevant literature as presently appearing in references .

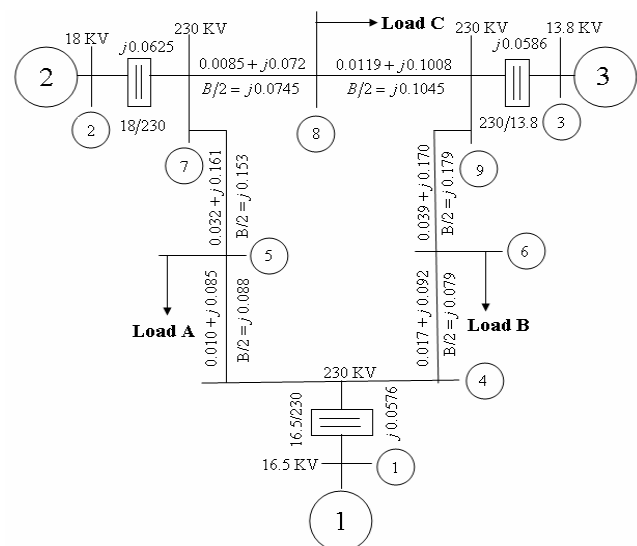

Figure 3. shows multi-machine system.

The base MVA of the system is 100, and system frequency is 60 Hz. The complete system been represented in terms of MATLAB/Simulink blocks. This model finds its utility for transient stability study the reason being power system configuration differs before fault and after fault. Multi-machine system with all the required components is modeled. The generator data is given in appendix A. All time constants are in seconds.

VI. MATLAB/SIMULINK MODEL OF MULTI-MACHINE (3-MACHINE 9-BUS) SYSTEM

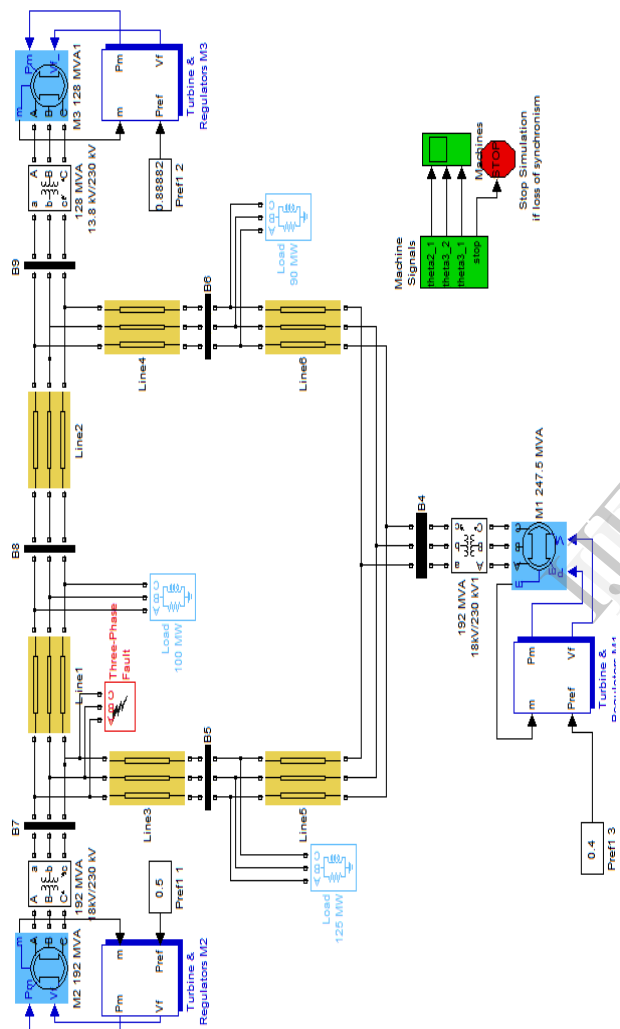

Figure 4. MATLAB/Simulink model of Multi-Machine System

VII. SIMULATION RESULTS FOR MULTI-MACHINE SYSTEM

A. STATCOM is placed between Bus 5 and Bus 4

STATCOM for the various cases has the following rating.

- Nominal Voltage = 230KV
- Frequency = 60Hz
- Converter Rating = 100MVA

- Converter Impedance $[R(pu),L(pu)] = [0.44/30,0.22]$
- Converter Initial current $[Mag(pu),Ph(deg)] = [50,35]$
- Vac Regulator Gain $[Kp, Ki] = [100, 2000]$
- Vdc Regulator Gain $[Kp, Ki] = [0.0001, 0.0032]$
- Current Regulator Gain $[Kp, Ki, Kf] = [0.3, 19, 0.33]$

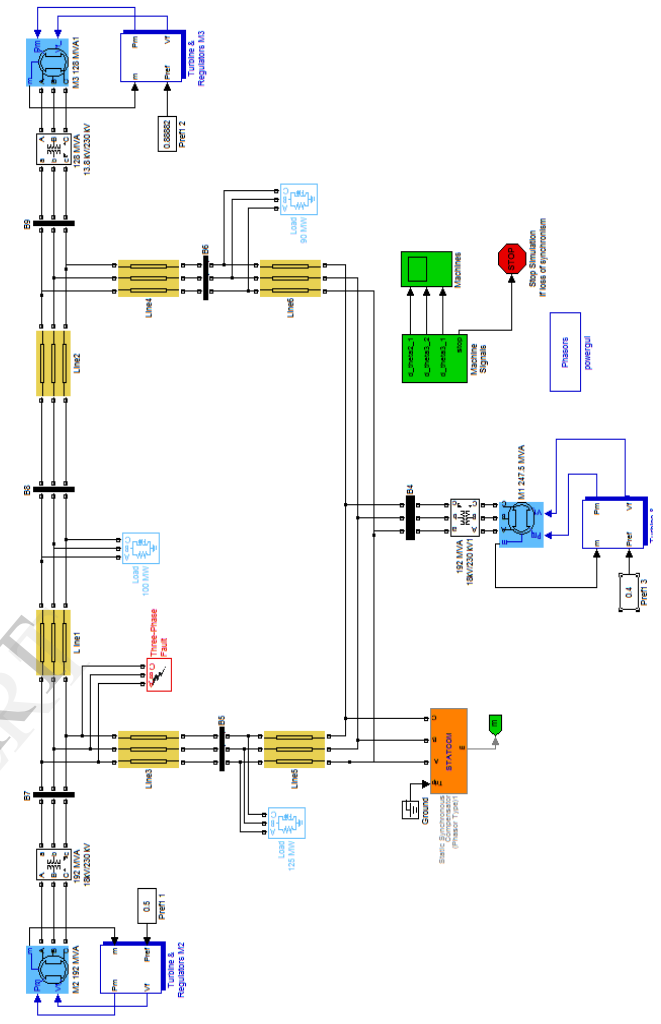

Figure 5. MATLAB/ Simulink model of Multi-Machine System with STATCOM Between Bus 5 and Bus 4

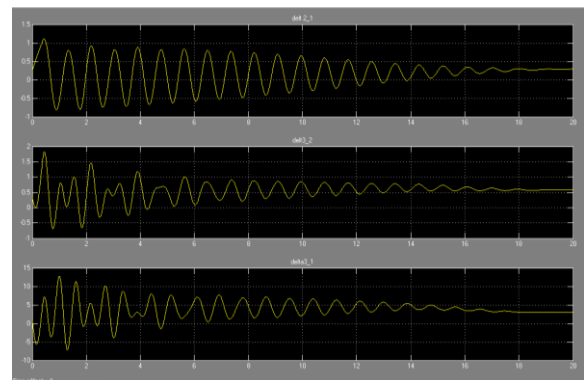

Figure 6 shows the relative angular positions for delta2_1, delta3_2 and delta3_1 multi-machine system with STATCOM controller placed between Bus 5 and Bus 4 and fault taking place between Bus 5 and Bus 7. The total simulation time taken is 20 sec.

Table 1. Stability time for STATCOM placed between Bus 5 and Bus 4

FAULT POSITION	STATCOM POSITION	Stability time for delt2_1 (in sec.)	Stability time for delt3_2 (in sec.)	Stability time for delt3_1 (in sec.)
Between Bus 5 & Bus 7	Between Bus 5 & Bus 4	18	17.6	17

It is clear from the table that the time required by delt3_1 to get stable is minimum i.e 17 seconds.

b) UPFC is placed between Bus 5 and Bus 4

UPFC for the various cases has the following rating.

Nominal Voltage = 500KV Frequency = 60Hz Shunt Converter Rating = 100MVA

Shunt Converter Impedence [R(pu),L(pu)] = [0.22/30,0.22]

Series Converter Rating = 100MVA

Max. injected voltage(pu)=0.1

Shunt Converter Impedence [R(pu),L(pu)] = [0.16/30,0.16]

D.C link nominal voltage(v)=40000V

D.C link total equivalent capacitance(F)=750micro farad

Vac Regulator Gain [Kp, Ki] = [5 1000]

Vdc Regulator Gain [Kp, Ki] = [0.001, 0.020]

Current Regulator Gain [Kp, Ki] = [0.5, 25]/3

Series converter control parameters[Kp, Ki]=[0.025 1.5]

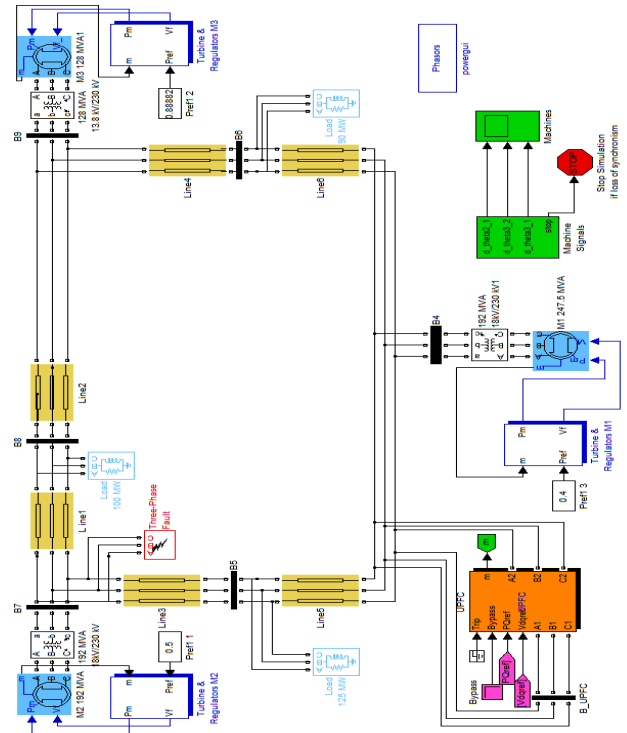

Figure 7 MATLAB/ Simulink Model Of Multi-Machine System With STATCOM Between Bus 5 And Bus 4

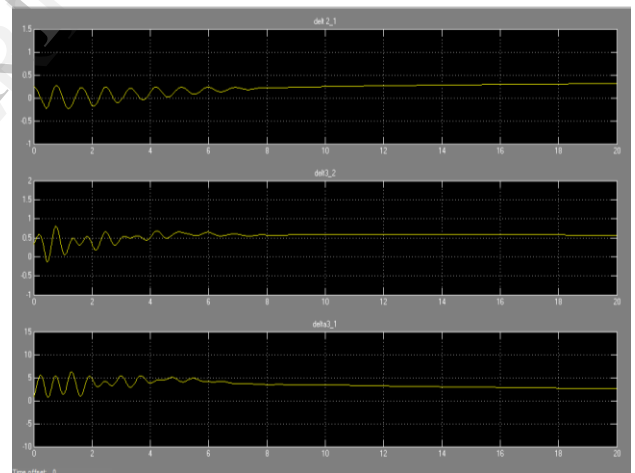

Figure 8 shows the relative angular positions for delt2_1, delt3_2 and delt3_1 multi-machine system with UPFC controller placed between Bus 5 and Bus 4 and fault taking place between Bus 5 and Bus 7. The total simulation time taken is 20 sec.

Table 2 : Stability time for UPFC placed between Bus 5 and Bus 4

FAULT POSITION	UPFC POSITION	Stability time for delt2_1 (in sec.)	Stability time for delt3_2 (in sec.)	Stability time for delt3_1 (in sec.)
Between Bus 5 & Bus 7	Between Bus 5 & Bus 4	8	7	6

It is clear from the table that the time required by delt3_1 to get stable is minimum i.e 6 seconds.

VIII. RESULTS

The results of those graphs are given below with both devices STATCOM & UPFC:-

FACTS CONTROLLER	STATCOM	UPFC
STATCOM & UPFC POSITION :- Between Bus 4 & Bus 5		
Stability time for delt2_1(in sec)	18	8
Stability time for delt3_2(in sec)	17.6	7
Stability time for delt3_1(in sec)	17	6

IX. CONCLUSION

The power system stability enhancement of a 3-machine 9 bus system by station & UPFC is compared and discussed. The dynamics of the system is compared with the presence of STATCOM & UPFC in the system in the event of a major disturbance. Then the performance of UPFC for power system stability improvement is compared with the STATCOM. It is clear from the simulation results that there is a considerable improvement in the system performance with the use of UPFC for which settling time in post fault is found to be around 4.7 sec.

REFERENCES

- [1] Baker, M. H., September 1995 "An Assessment of FACTS Controllers for Transmission System Enhancement," CIGRE SC 14 International Colloquium on HVDC & FACTS, Montreal.
- [2] Cavaliere, C.A.C. Watanabe, E.H.Aredes, M.2002" Multi-pulse STATCOM Operation Under Unbalanced Voltages" , Proceedings of the IEEE Power Engineering Society Winter Meeting, 2002.,Vol.1, pp 567- 572, 2002.
- [3] De Assis, T.M.L.,Watanabe, E.H.,Pilotto, L.A.S, Sollero, R.B 2002."A New Technique to Control Reactive Power Oscillations using STATCOM" Proceedings of the IEEE International Conference Harmonics and Quality of Power ,Vol.2, pp 607-613
- [4] El Moursi, M.S., Sharaf, A.M., 2005 "Novel Controllers for the 48-pulse VSC STATCOM and SSSC for Voltage Regulation and Reactive Power Compensation"Proceedings of the IEEE Power Systems ,Vol 20,Issue 4, pp 1985- 1997.,
- [5] Haque, M.H., 2005. "Stability Improvement by FACTS Devices- A Comparison between STATCOM and SSSC", Proceedings of the IEEE Power Engineering Society General Meeting, , Vol. 2, pp 1708- 1713.
- [6] Huwag A.F,Bashi S.M,Marium N,2004 "A STATCOM Simulation Model to Improve Voltage Sag Due to Starting of High Power Induction Motor" Proceedings of the IEEE National Power and Energy Conference (PE Con 2004), pp 148-152.
- [7] Jianye Chen,Shan Song, Zanji Wang 2006 "Analysis and Implement of Thyristor-Based STATCOM", Proceedings of the IEEE International Conference Power System Technology,(Power Con2006). pp 1-5
- [8] K.R. Padiyar,2002 "FACTS Controllers in Power Transmission and Distribution", New Age International (P) Limited, Publishers.
- [9] Kundur. P, Paserba. J, Ajarapu. V, Andersson. G, Bose. A, Canizares.C, Hatziaargyriou. N, Hill. D, Stankovic. A, Taylor. C, Cutsem. T. U, Vittal. V,2004 "Definition and Classification of Power System Stability,"IEEE Trans. on PowerSystems, Vol. 19, pp 1387-1401.
- [10] Li Chun, Jiang Qirong,Xu Jianxin2000" Investigation of Voltage Regulation Stability of Static Synchronous Compensator in Power System", Proceedings of the IEEE Power Engineering Society Winter Meeting, 2000,Vol.4, pp 2642-2647.
- [11] Mahajan Vasundhara Oct 2008"Power System Stability Improvement with Flexible AC Transmission System (FACTS) Controller" Proceedings of IEEEPower India Conference (POWERCON 2008), pp 1-7.
- [12] Murali D, Rajaram M,2009"Transient Energy Analysis for STATCOM and SSSC Application" International Journal of Electrical and Power Engineering, Vol 3, Issue 4, pp 191-197.