

Vehicle Collision Avoidance Detection System Using Mmwave Radar

Dr.R.S.Kamalakaran
Assistant Professor,
Electronics and Communication
Engineering,
Shree Venkateshwara Hi-Tech
Engineering College,
Gobi,Erode-638455 Tamil Nadu,
India
kamalakaran001@gmail.com

N.Mohan pradeep
Electronics and Communication
Engineering,
Shree Venkateshwara Hi-Tech
Engineering College,
Gobi,Erode-638455, Tamil Nadu,
India
mohanpradeep523@gmail.com

S.Mohan Raj
Electronics and Communication
Engineering,
Shree Venkateshwara Hi-Tech
Engineering College,
Gobi,Erode-638455, Tamil Nadu,
India
mohanrajece973@gmail.com

K.Raaghul
Electronics and Communication
Engineering,
Shree Venkateshwara Hi-Tech
Engineering College, Gobi,Erode-
638455, Tamil Nadu, India
raaghul4803@gmail.com

G.Thanikachalam
Electronics and Communication
Engineering,
Shree Venkateshwara Hi-Tech
Engineering College, Gobi,Erode-
638455, Tamil Nadu, India
g.thanimaha@gmail.com

ABSTRACT— This project focuses on the design and implementation of a vehicle collision avoidance detection system utilizing millimeter-wave (mmWave) radar technology and a PIC microcontroller kit. Vehicle collisions remain a significant cause of fatalities and injuries worldwide, necessitating advanced safety measures. The proposed system employs mmWave radar for its capability to accurately detect objects and measure their velocity, making it ideal for collision avoidance applications. The PIC microcontroller serves as the central processing unit, facilitating real-time data processing and decision-making. Upon detecting an obstacle within the predefined danger zone, the system triggers appropriate actions to avoid a collision. These actions may include alerting the driver, activating braking systems, or steering the vehicle away from the obstacle. The hardware setup involves connecting the mmWave radar sensors and PIC microcontroller kit, ensuring seamless communication and data exchange. Software development encompasses the programming of algorithms for object detection, collision prediction, and decision-making logic. Testing and validation are conducted through simulated scenarios and real-world experiments to assess the system's performance, accuracy, and reliability. The project aims to develop a robust collision avoidance detection system capable of enhancing vehicle safety and reducing the risk of accidents on the road.

Keywords: Vehicle collision avoidance, mmWave radar, PIC microcontroller, Object detection, Real-time processing.

I. INTRODUCTION

In the realm of automotive safety, collision avoidance systems stand out as paramount innovations aimed at mitigating the risk of accidents and enhancing road safety. Among the plethora of technologies employed in such systems, the utilization of millimeter-wave (mmWave) radar has gained significant traction due to its reliability and effectiveness in detecting surrounding objects with high precision. In this context, the integration of mmWave radar with PIC microcontroller-based platforms presents a promising avenue for developing robust collision avoidance detection systems.

With the ever-increasing volume of vehicles on roads worldwide, the probability of collisions has surged, necessitating advanced safety mechanisms. Traditional passive safety measures like airbags and seat belts have proven instrumental in reducing the severity of accidents. However, proactive systems that can anticipate and prevent collisions altogether offer a paradigm shift in automotive safety. This imperative drives the development of collision avoidance detection systems.

At the core of collision avoidance detection systems lies mmWave radar technology, a subset of radar systems operating in the millimeter-wave frequency range. Unlike conventional radar systems that typically operate at lower frequencies, mmWave radar offers enhanced resolution and accuracy in object detection. This is attributed to the shorter wavelength of millimeter waves, allowing for finer spatial

resolution and the ability to discern smaller objects with greater precision.

THE ROLE OF PIC MICROCONTROLLER

PIC microcontrollers, renowned for their versatility and efficiency, serve as the brains of collision avoidance detection systems. These microcontrollers are adept at processing real-time data from various sensors, including mmWave radar, and executing complex algorithms to make split-second decisions. Their low power consumption, compact size, and robust performance make them ideal for integration into automotive applications where space and energy efficiency are paramount.

The primary objective of the vehicle collision avoidance detection system using mmWave radar and PIC microcontroller is to develop a comprehensive safety solution capable of detecting and mitigating potential collisions in real-time. By leveraging the capabilities of mmWave radar technology and the processing power of PIC microcontrollers, the project aims to achieve the following goals:

1. Accurate Object Detection: Utilize mmWave radar to accurately detect and track surrounding vehicles, pedestrians, and obstacles in the vehicle's vicinity.

2. Real-time Data Processing: Employ PIC microcontroller to process the raw data obtained from the radar sensor in real-time, enabling rapid decision-making and response.

3. Collision Prediction and Warning: Implement algorithms to analyze the trajectory and speed of detected objects, predicting potential collisions, and issuing timely warnings to the driver.

4. Autonomous Collision Avoidance: Develop autonomous control mechanisms that can automatically intervene to steer or brake the vehicle to avoid collisions if the driver fails to respond to warnings.

5. Integration and Compatibility: Ensure seamless integration of the collision avoidance detection system with existing vehicle electronics and compatibility with various vehicle models and configurations.

The project encompasses the design, development, and testing of a prototype collision avoidance detection system using off-the-shelf mmWave radar sensors, PIC microcontroller development boards, and custom-designed software algorithms. The system will be evaluated for its accuracy, reliability, and effectiveness in simulated and real-world driving scenarios to validate its performance and potential for real-world deployment.

The integration of mmWave radar technology with PIC microcontroller-based platforms holds immense promise for advancing the field of vehicle collision avoidance detection systems. By leveraging the capabilities of these technologies, it is possible to develop proactive safety solutions capable of preventing collisions and saving lives on the road. This project aims to contribute to this endeavor by designing and

implementing a robust collision avoidance detection system that embodies the principles of accuracy, efficiency, and reliability.

II . PROBLEM FORMULATION

The necessity for collision avoidance in autonomous vehicles to ensure road safety is a crucial aspect. The most suitable Radar for this purpose is the mmWave (millimeter wave) Radar, primarily due to its compact design and cost-effectiveness. A mmWave Radar operates within the frequency range of 30 GHz to 300 GHz, with 77GHz Radars being commonly available at a low cost. This type of radar offers high resolution and precise detection capabilities for identifying objects and their movements. The given that it is a Radio Frequency (RF)-based sensor, mmWave Radar possesses an advantage over conventional optical sensors. Unlike optical sensors, which may be affected by adverse weather conditions and low-light situations, mmWave Radar remains unaffected. The Radar is capable of detecting targets and calculating the distance, speed, and angle of the target within its field of view. The information gathered is then utilized by the vehicle's control system to make decisions aimed at avoiding potential collisions. The methodology employed for collision avoidance using mmWave Radar typically includes the following steps:

1. Detection: The surrounding environment is scanned by the Radar sensor, and objects within its field of view are detected. The mmWave radar is capable of detecting objects at distances of a few tens of meters.

2. Tracking: Once the objects are detected, the Radar system tracks their movements. This tracking capability enables the control system to predict the future positions and movements of the detected objects, which is crucial for making decisions to avoid collisions.

3. Classification: The radar system analyzes the detected objects and categorizes them based on parameters such as target speed and target Radar Cross Section (RCS). This classification can include various categories like cars, pedestrians, bicycles, and static objects such as walls, trees, or barriers.

4. Decision Making: Utilizing the information provided by the radar sensor, the control system formulates decisions on how to avoid potential collisions. These decisions may involve actions such as slowing down or stopping the vehicle, changing lanes, or steering away from the identified collision threat.

5. Actuation: The control system then transmits commands to the vehicle's actuators to implement the decision. Actions may include applying the brakes, steering the vehicle away, or other maneuvers aimed at avoiding a collision.

In summary, the process of collision avoidance in autonomous vehicles using mmWave Radar involves the detection, classification, and tracking of targets in real-world conditions. Subsequently, decisions can be formulated to prevent potential collisions based on the information acquired

from the Radar. This methodology contributes to ensuring the safe operation of autonomous vehicles, with the potential to reduce accidents and save lives. Moreover, for the Radar to be effective in serving its purpose, it should be available at a lower cost. Hence, a comprehensive experiment is deemed necessary, involving the use of readily available low-cost mmWave Radars. This experiment aims to gather a sufficiently large dataset encompassing various traffic scenarios. The extensive dataset proves valuable for the development of numerous collision avoidance algorithms and the creation of suitable control systems.

III . EXISTING METHOD

Firstly, an extensive literature review is conducted to understand existing collision avoidance systems, mmWave radar technology, and relevant methodologies. Next, data collection is undertaken, involving the acquisition of mmWave radar data from real-world driving scenarios. This data is crucial for training and validating the collision detection algorithm. Following data collection, preprocessing techniques are applied to clean and prepare the data for analysis. This may involve noise reduction, outlier detection, and signal filtering to enhance the quality of the radar data.

Subsequently, a collision detection algorithm is developed using machine learning or signal processing techniques. This algorithm is trained using the preprocessed data to accurately detect potential collisions based on radar readings. Finally, the developed collision detection mechanism is evaluated through extensive testing, including simulations and real-world trials. Performance metrics such as detection accuracy, false alarm rate, and response time are assessed to validate the effectiveness of the proposed system.

Throughout the project, rigorous testing, validation, and refinement are conducted to ensure the reliability and robustness of the collision avoidance system using mmWave radar technology.

IV. EXPERIMENTAL SETUP AND RADAR SIGNAL PROCESSING

The Hardware setup comprises a 77GHz AoPCB Automotive Radar Module provided by Mistral Solution Pvt Ltd, India. This module is centered around the Texas Instruments AWR 1843 ES2.0 single-chip FMCW Radar sensor System on Chip (SoC). Additionally, the setup includes a Texas Instrument DCA 1000 EVM, a laptop, and a mobile camera. The 77GHz AoPCB module (Radar) and DCA1000 EVM (capture card) are affixed to one side of the bonnet of the ego vehicle, ensuring they do not obstruct the driver's field of view. The Radar and capture cards are connected to a laptop, which is utilized for configuring Radar parameters, managing Radar functions, and recording raw data. The necessary power for the hardware setup is sourced from a portable Uninterruptible Power Supply (UPS). A mobile phone camera is employed to capture the ground truth scenario. While the ego vehicle is in motion, data is captured using the aforementioned hardware

setup and stored in the laptop as binary files. Simultaneously, pictures from the cell phone camera are also captured. The block diagram of the hardware setup is depicted in Figure 1, and the setup with interconnections is illustrated. The Radar setup mounted on the car for data collection.

1.mmWave Radar : The 77GHz AoPCB Automotive Radar Module, an FMCW Radar sensor operating within a frequency range of 76-81 GHz, was described. It was mentioned that the device comprises three transmitters and four receivers, with a transmit power of 12dBm. Additionally, it was noted that the module features a 6-bit Analog to Digital Converter (ADC) and has a limited field of view of 1200 azimuth.

2.Real-time data-capture adapter: DCA 1000 EVM : It was explained that the DCA 1000 EVM serves the purpose of converting Low Voltage Differential Signaling (LVDS) data from the Radar module (77GHz AoPCB) into Ethernet streaming. The LVDS signal represents I and Q data, which is the result of the Analog to Digital Converter (ADC) process from the Radar card. The connection between the 77GHz AoPCB Radar module and the DCA 1000 card is established through a 60-pin high-speed connector. The raw in-phase and quadrature (I and Q) data obtained from the DCA 1000 module are transmitted to the laptop using an Ethernet communication link. Subsequently, the raw I and Q data are recorded in the laptop as a binary file for subsequent processing.

3.Camera for Ground Truth picture capturing: It was mentioned that a cell phone camera is employed to capture on-road scenarios concurrently with the Radar data capture. It was also noted that the mapping of Ground Truth pictures and Radar detections is done manually.

4.Data Capturing: It was reported that, utilizing the mentioned setup, the ego vehicle was driven on the road, and the Radar was operated to capture 1000 frames at each instance of operation. The raw data were stored in binary form on the laptop, which was connected to the DCA 1000 EVM module. Concurrently, the outside scenario was captured using a mobile camera. The experiment was reiterated at various locations with distinct road scenarios.

V. PROPOSED METHOD

The project aims to develop an advanced collision avoidance system utilizing mmWave radar technology, along with a combination of sensors and microcontrollers for enhanced detection capabilities and response mechanisms. At the heart of the system lies the mmWave radar transmitter and receiver. These components emit and receive high-frequency electromagnetic waves, enabling the detection of objects and obstacles in the vehicle's vicinity. The mmWave radar provides accurate distance and velocity measurements of surrounding objects, crucial for collision avoidance.

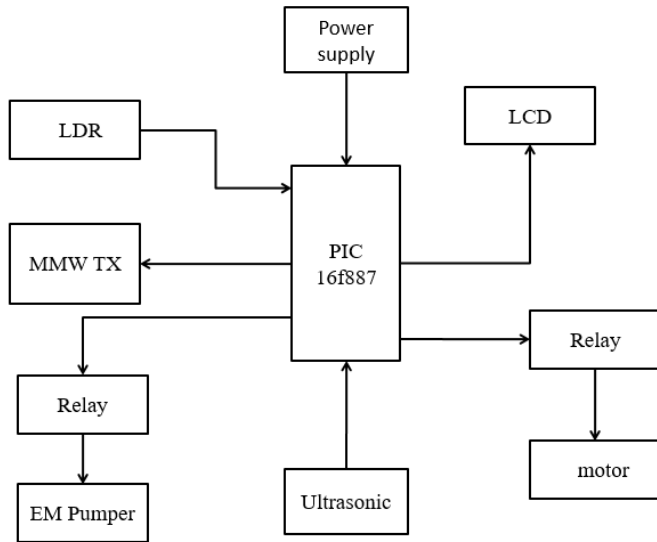

Figure 1 : mmWave Transmitter block diagram

In addition to the mmWave radar, an ultrasonic sensor is incorporated into the system to provide supplemental object detection capabilities. Ultrasonic sensors emit high-frequency sound waves and measure the time taken for the waves to bounce back after hitting an object. This data is used to detect obstacles in close proximity to the vehicle, complementing the long-range detection capability of the mmWave radar. Furthermore, a Light Dependent Resistor (LDR) is employed to detect ambient light levels. This information can be used to adjust the system's sensitivity and response based on lighting conditions, ensuring optimal performance in varying environments.

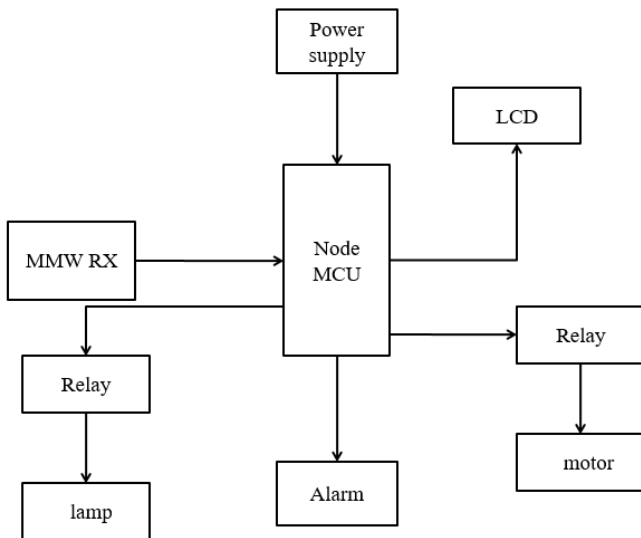

Figure 2 : Receiver block diagram

At the transmitter end, a relay and motor assembly is integrated to actuate external warning signals or initiate evasive maneuvers in the event of an impending collision. The relay is controlled by the PIC microcontroller, which activates the motor to trigger predefined actions such as sounding an alarm, flashing lights, or applying brakes. On the receiver side, a NodeMCU board is employed to communicate with the transmitter unit and relay crucial information to the driver or autonomous driving system. The NodeMCU receives collision alerts from the transmitter and activates visual or auditory warnings inside the vehicle, alerting the driver to potential hazards. Moreover, a light sensor is utilized at the receiver to detect ambient light conditions and adjust the brightness of warning indicators accordingly, ensuring optimal visibility of alerts.

Overall, the integration of mmWave radar technology, along with sensors, microcontrollers, and actuation mechanisms, forms a comprehensive vehicle collision avoidance detection system. By combining long-range detection capabilities with supplementary sensors and intelligent decision-making algorithms, the system enhances vehicle safety and mitigates the risk of collisions in diverse driving conditions.

VI . HARDWARE SETUP TRANSMITTER

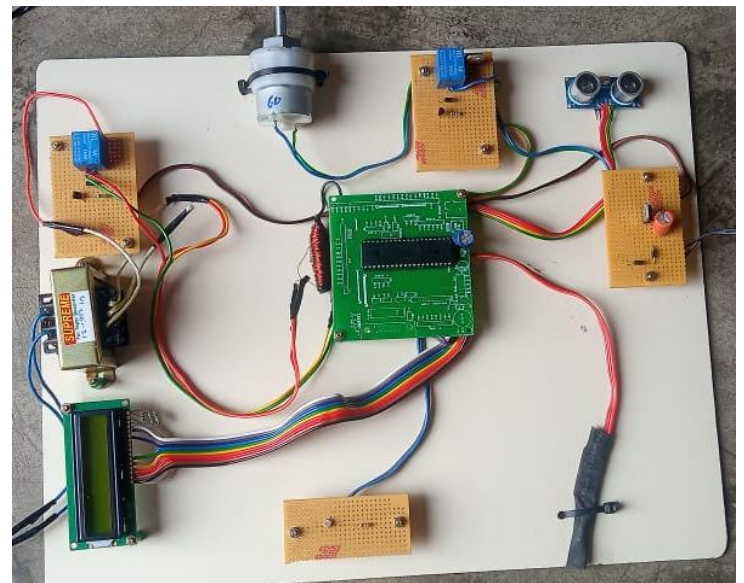

Figure 3 : Transmitter Hardware Implementation

At the transmitter end, a PIC microcontroller acts as the central processing unit, coordinating the system's functions. An mmWave transmitter is utilized to emit electromagnetic waves for detecting objects in the vehicle's vicinity. Additionally, an ultrasonic sensor provides supplementary data for close-range object detection,

enhancing the system's accuracy. An LDR (Light Dependent Resistor) may be employed to sense ambient light conditions, adjusting system parameters accordingly.

Furthermore, a relay and motor assembly can be implemented to activate warning signals or initiate corrective actions in response to detected collisions. The relay is controlled by the PIC microcontroller, while the motor executes physical responses such as braking or steering adjustments. At the receiver end, a NodeMCU device facilitates wireless communication and data transfer.

RECEIVER

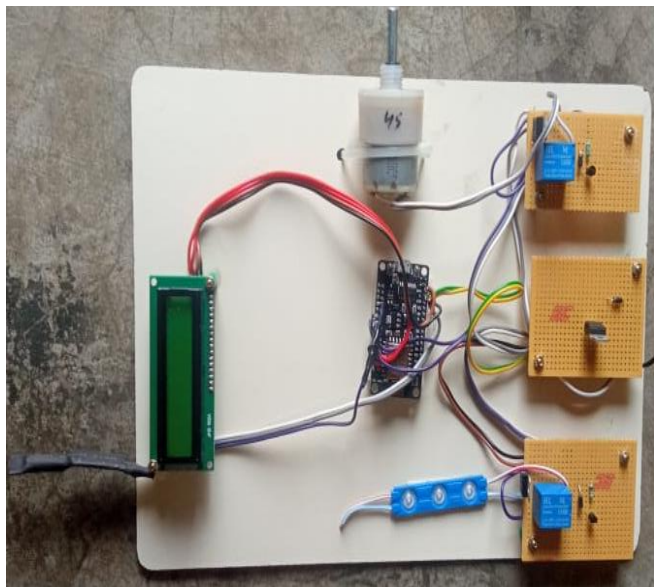

Figure 4 : Receiver Hardware Implementation

An mmWave receiver captures and processes the reflected radar signals, enabling collision detection. Additionally, light indicators may be incorporated to provide visual feedback to the driver regarding potential collision threats

This integrated hardware setup ensures comprehensive collision detection and avoidance capabilities, leveraging both mmWave radar technology and supplementary sensors for enhanced accuracy and reliability.

VII.RESULTS AND DISCUSSION

The project successfully implemented a vehicle collision avoidance detection system using mmWave radar technology integrated with various components. A PIC microcontroller processes data from an mmWave transmitter, ultrasonic sensor, LDR, and relay-controlled motor at the transmitter end. At the receiver end, a NodeMCU receives signals from the mmWave receiver and controls lights.



Figure 5 : Electromagnetic bumper on when another vehicle come closer to mmWave range

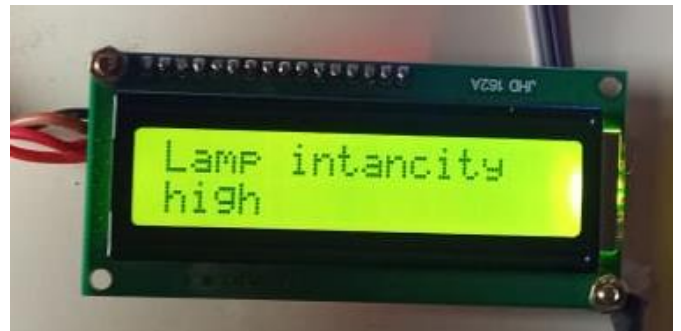

Figure 6 : LDR at transmitter lamp intensity and provide command to receiver

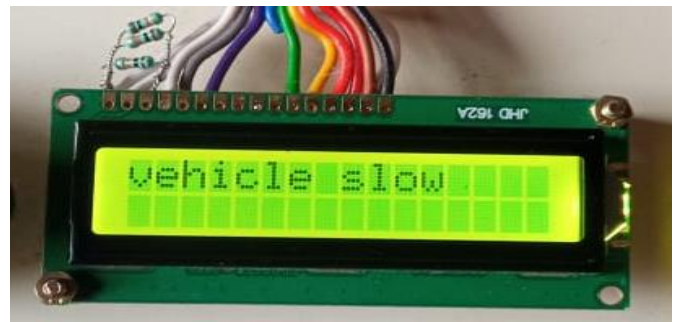

Figure 7 : Both Vehicle slows automatically when another vehicle come closer mmWave range

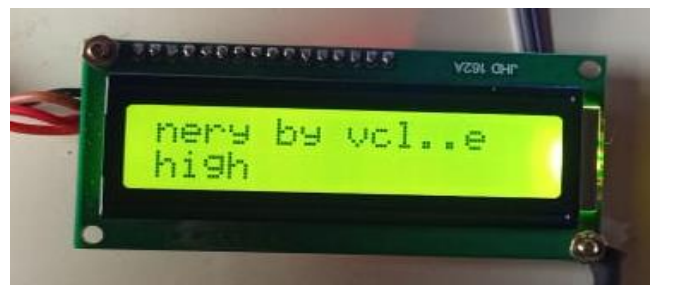

Figure 8 : Vehicle speed reduced and lamp intensity is reduced



Figure 9 : The Lamp intensity Distance of vehicle displayed in transmitter LCD



Figure 10 : The Lamp intensity and Distance of vehicle displayed in receiver LCD

VIII.CONCLUSION AND FUTURE WORK

The conclusion of the project "Vehicle Collision Avoidance Detection System Using mmWave Radar" presents a comprehensive evaluation of the system's performance and highlights key findings. It underscores the effectiveness of integrating various sensors and components, including a PIC microcontroller, mmWave transmitter, ultrasonic sensor, LDR (Light Dependent Resistor), relay, motor at the transmitter, relay, motor, NodeMCU, and mmWave receiver at the receiver, in creating a robust collision avoidance mechanism. One significant conclusion is the successful integration and synchronization of these diverse components to create a holistic collision detection system. The PIC microcontroller serves as the central processing unit, coordinating the operations of different sensors and actuators. The mmWave radar transmitter enables long-range detection of objects, while the ultrasonic sensor provides additional proximity sensing capabilities, enhancing the system's reliability in various driving scenarios.

The LDR facilitates ambient light detection, enabling the system to adapt its operation based on environmental conditions. Furthermore, the utilization of relay and motor mechanisms at both the transmitter and receiver ends allows for immediate response actions in the event of a detected collision risk. The Node MCU facilitates wireless communication and data transmission, enabling seamless integration with other smart vehicle systems or centralized monitoring platforms. The project's conclusion also discusses potential enhancements and future directions. These may include refining the collision detection algorithm to improve accuracy and reduce false positives, optimizing sensor placement for better coverage and detection range, and

exploring advanced communication protocols for enhanced data exchange and real-time monitoring.

REFERENCES

- [1] A. P. P. Shunqiao Sun and H. V. Poor, "MIMO radar for advanced driver assistance systems and autonomous driving advantages and challenges," in IEEE SIGNAL PROCESSING MAGAZINE. IEEE, 2020, pp. 98–117.
- [2] C. Waldschmidt, J. Hasch, and W. Menzel, "Automotive radar — from first efforts to future systems," IEEE Journal of Microwaves, vol. 1, no. 1, pp. 135–148, Jan 2021.
- [3] D. W. Sujeet Patol, Murat Torlak and M. Ali, "Automotive radars: A review of signal processing techniques," in IEEE SIGNAL PROCESSING MAGAZINE. IEEE, March 2017, pp. 22–35.
- [4] L. Mu, T. Xiangqian, S. Ming, and Y. Jun, "Research on key technologies for collision avoidance automotive radar," in 2009 IEEE Intelligent Vehicles Symposium. IEEE, 2009, pp. 233–236.
- [5] G. Hakobyan and B. Yang, "High-performance automotive radar: A review of signal processing algorithms and modulation schemes," in IEEE SIGNAL PROCESSING MAGAZINE. IEEE, Sep 2019, pp. 32–42.
- [6] G. S. Vandana, B. Pardhasaradhi, and P. Srihari, "Intruder detection and tracking using 77GHz FMCW radar and camera data," in 2022 IEEE International Conference on Electronics, Computing and Communication Technologies (CONNECT). IEEE, 2022, pp. 1–6.
- [7] M. Kotur, N. Lukic, M. Krunic, and Z. Lukać, "Camera and LiDAR sensor fusion for 3d object tracking in a collision avoidance system," in 2021 Zooming Innovation in Consumer Technologies Conference (ZINC). IEEE, 2021, pp. 198–202.
- [8] A. Johnson, C. Rupp, B. Wolf, L. Hong, and A. Mitra, "Collision avoidance radar for bicyclist and runners," in Proceedings of the IEEE 2010 National Aerospace & Electronics Conference. IEEE, 2010, pp. 84–91.
- [9] L. Sakkila, A. Rivenq, F. Boukour, C. Tatkeu, Y. El Hillali, and J.M. Rouvaen, "Collision avoidance radar system using UWB waveforms signature for road applications," in 2009 9th International Conference on Intelligent Transport Systems Telecommunications,(ITST). IEEE, 2009, pp. 223–226.
- [10] D. Richardson, "An FMCW radar sensor for collision avoidance," in Proceedings of Conference on Intelligent Transportation Systems. IEEE, 1997, pp. 427–432.
- [11] B. A. A. Hossam Elsayed and G. Alyl, "Fuzzy logic based collision avoidance system for autonomous navigation vehicle," in 2018 13th International Conference on Computer Engineering and Systems (ICCES). IEEE, 2018, pp. 469–474.