

# Voltage Sag Mitigation Using SMES Based DVR Technology

Prof. Himali Chaudhari

M.E. student, Dept. of Electrical Engineering  
K.K.W.C.O.E.R., Nashik

Prof. D. P. Kadam

Associate Professor, Dept of Electrical  
Engineering K.K.W.C.O.E.R., Nashik

**Abstract** - This paper describes the super conducting magnetic energy storage SMES based dynamic voltage restorer to protect consumers from the grid voltage fluctuations. DVR can be effectively provide a fine solution to power quality related concerns. As per the PQ issues sag is the mostly happen problem. By the Superconducting magnetic energy storage (SMES) technology based DVR the sag is mitigated and real power is restored and thus wastage is overcome, providing protection to consumers from grid voltage fluctuations. . Due to the characteristic of high energy density and quick response, a superconducting magnet is selected as the energy storage unit to improve the compensation capability of DVR. This paper analyses the operation principle of the SMES based DVR, and designs the DVR output voltage control method using MATLAB SIMULINK, the models of the SMES based DVR is established, and the simulation tests are performed to evaluate the system performance.

**Keywords**- Dynamic Voltage Restorer (DVR), power conditioning system (PCS), voltage sags, custom power and power quality.

## 1. INTRODUCTION

Now day's power systems have been experiencing drastic changes and disturbances in electric power generation, Transmission, distribution, and end-user facilities. Wide application of power electronic devices in power system makes power quality an important issue in today's power scenario. It is the duty of the utility to supply a pure sinusoidal voltage of required magnitude and frequency at all the time and without any deviation to its consumers. But, in reality it is not possible to see ideal waveforms. The voltage waveforms are disturbed from ideal waveform due to occurrence of disturbances like voltage sag, voltage swell, interruptions, flicker fluctuations etc. and also due to the use of non-linear loads. Such voltage distortion adversely affects the performance of equipment connected in the system. The industries like process industries, petrochemical industries, semiconductor industries, chemical industries, paper mills etc. use equipment's which are very sensitive to voltage distortion. Poor voltage quality may result in termination of the process, loss of data in

## SMES DEVICE

SMES systems are a developing technology which utilise the properties of superconducting material to store energy in magnetic fields. SMES systems have very fast charge and discharge times which make them an attractive energy storage system for sag mitigation. Another advantage of

digital devices etc., and hence huge financial loss to consumer. Out of the various voltage disturbances, voltage sag is a frequent disturbance in power system. 92% of the interruptions in industrial installations are due to voltage sags.

So in order to overcome this deficiency SMES based DVR has been used to improve the performance of power system as it is having high power rating with maximum efficiency then any other energy storage devices. In this paper proposes a super conducting magnetic energy storage unit, as the energy storage unit of DVR.

## CONFIGURATION OF SMES BASED DVR:-

Dynamic Voltage Restorer (DVR) is one of the effective custom power devices that can be used to improve power quality from any disturbances in the distribution line. The DVR can be used for protection and recovery or restore the quality of voltage to the sensitive load. A set of three phase voltages with an appropriate magnitude and duration can be injected through injection transformer and must be in phase with the grid voltage [8]. A DVR is a solid state power electronics switching device consisting of either GTO or IGBT, a capacitor bank as an energy storage device and injection transformers.

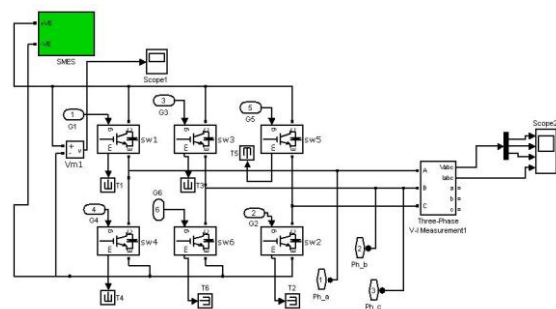

SMES systems is the very low losses due to the superconducting characteristics. It consists of super conducting magnetic energy storage unit, capacitor bank, VSI, low pass filter and voltage induction transformer. It consists of main system and its sub systems. The super conducting coil is the important section of SMES system, which is placed in a cryostat or dewar consisting of a

vacuum vessel and a liquid vessel. Liquid vessel keeps the system temperature by providing proper cooling setup cryogenic system, also keeps the temperature below the critical temperature. Finally a transformer which provides the power system connection and co-ordination and PCS operating voltage will reduce to acceptable levels.

**CONTROL SECTION**

Voltage sag is created at load terminals by three phase faults. Load voltage is converted into per unit quantity. Then the magnitude is compared with the reference voltage through which error signal is fed to PI controller. The voltage is then fed to triggering circuit SPWM (sinusoidal pulse width modulated ) control technique is applied for inverter switching so as to produce three phase sinusoidal voltage at the load terminals. The PI controller processes the error signal and generates the required angle  $\delta$  to drive the error to zero PI controller input is an actuating signal which is a difference between  $V_{ref}$  and  $V_{in}$ .

The controller output compared at SPWM signal generator results in desired firing sequence. The basic functions of a controller in a DVR are the detection of voltage sag/swell events in the system; computation of the correcting voltage, generation of trigger pulses to the sinusoidal PWM based DC-AC inverter, correction of any

anomalies in the series voltage injection and termination of the trigger pulses when the event has passed. The controller may also be used to shift the DC-AC inverter into rectifier mode to charge the capacitors in the DC energy link in the absence of voltage sags/swells. The dqo transformation or Park's transformation is used to control of DVR. The dqo method gives the sag depth and phase shift information with start and end times. The quantities are expressed as the instantaneous space vectors. Firstly convert the voltage from a-b-c reference frame to d-q-o reference. For simplicity zero phase sequence components is ignored. The detection is carried out in each of the three phases. the measured terminal voltage ( $V_a, V_b, V_c$ ). The voltage sags is detected when the supply drops below 90% of the reference value whereas voltage swells is detected when supply voltage increases up to 25% of the reference value. The error signal is used as a modulation signal that allows to generate a commutation pattern for the power switches (IGBT's) constituting the voltage source converter. The commutation pattern is generated by means of the sinusoidal pulse width modulation technique (SPWM); voltages are controlled through the Modulation The PLL circuit is used to generate a unit sinusoidal wave in phase with mains voltage.

The fig. shows Simulink model of matlab circuit of SMES based DVR.

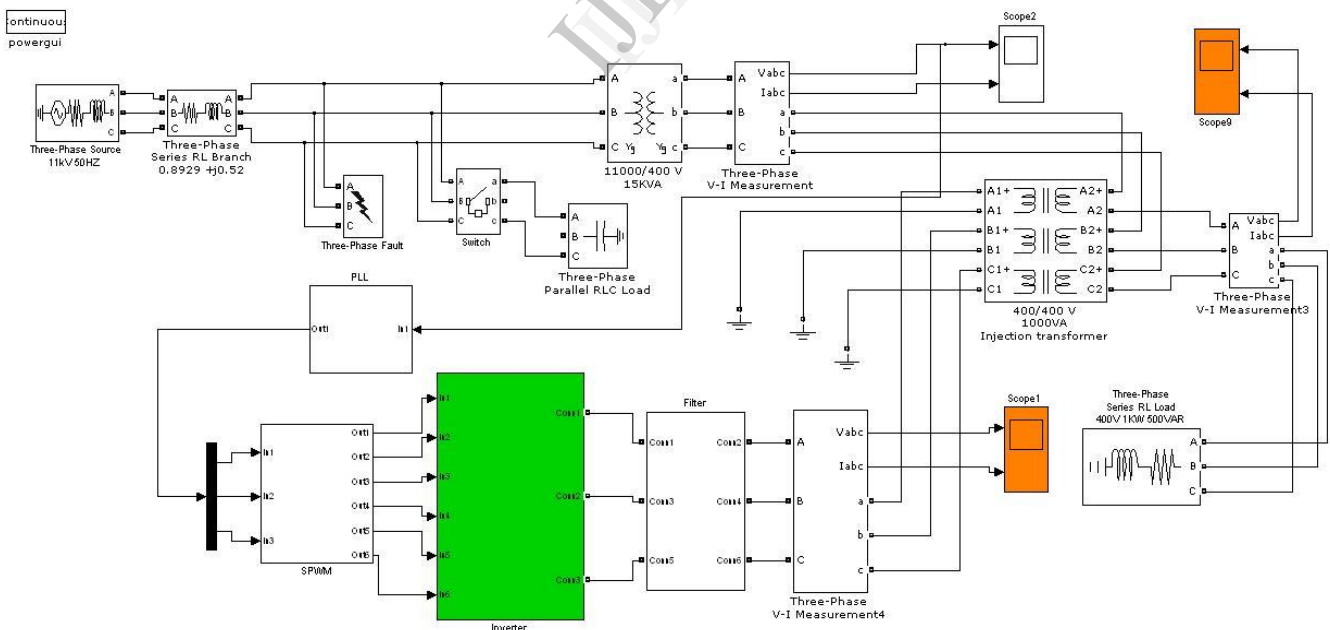

### SIMULATION RESULTS

The fault occurs at 0.2 sec

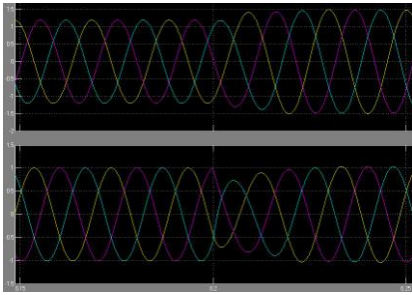

The inverter operates and simulates the fault at 0.2 sec

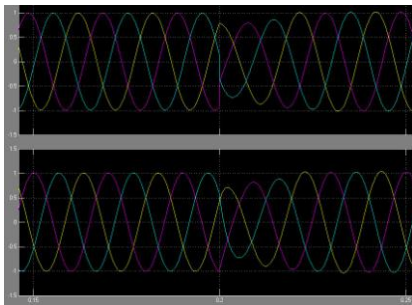

### CONCLUSION

A design of superconducting magnetic energy storage module as a dc voltage source to mitigate voltage sags and enhance power quality of a distribution system based on DVR has been presented. The simulation results prove that the SMES based DVR compensate the sags quickly and provide excellent voltage regulation the DVR handles both balanced and unbalanced situation without any difficulties and injects the appropriate voltage. The simulation shows that DVR performance is satisfactory in mitigating voltage sags.

### REFERENCES

1. N.G. Hingorani, "Introducing Custom Power in IEEE Spectrum," 32p, pp. 41-48, 1995.
2. IEEE Std. 1159 – 1995, "Recommended Practice for Monitoring Electric Power Quality".
3. P. Boonchiam and N. Mithulananthan, "Understanding of Dynamic Voltage Restorers through MATLAB Simulation," Thammasat Int. J. Sc. Tech., Vol. 11, No. 3, July-Sept 2006.
4. M.H.Haque "Compensation of distribution system voltage sag by DVR and DSTATCOM" Power Tech Proceedings, 2001 IEEE Porto, Volume: 1, 10-13 Sept.2001 Pages: 5 pp. vol.1.
5. IEEE Task Force on Benchmark Models for Digital Simulation of FACTS and Custom-Power Controllers,T&DCommittee," Detailed Modeling of Superconducting Magnetic Energy Storage (SMES) System", IEEE TRANSACTIONS ON POWER DELIVERY, VOL. 21, NO. 2, APRIL 2006.
6. Jianxun Jin and Xiaoyuan Chen, "HTS Inductive Magnetic Energy Storage with Power Control Technology ."
7. H.P. Tiwari, Sunil Kumar Gupta , "DVR Based On Fuel Cell: An Innovative Back-Up System," , International Journal of Environmental Science and Development, Vol.1, No.1, April 2010, ISSN:2010-02.